

SITE DIAGRAM

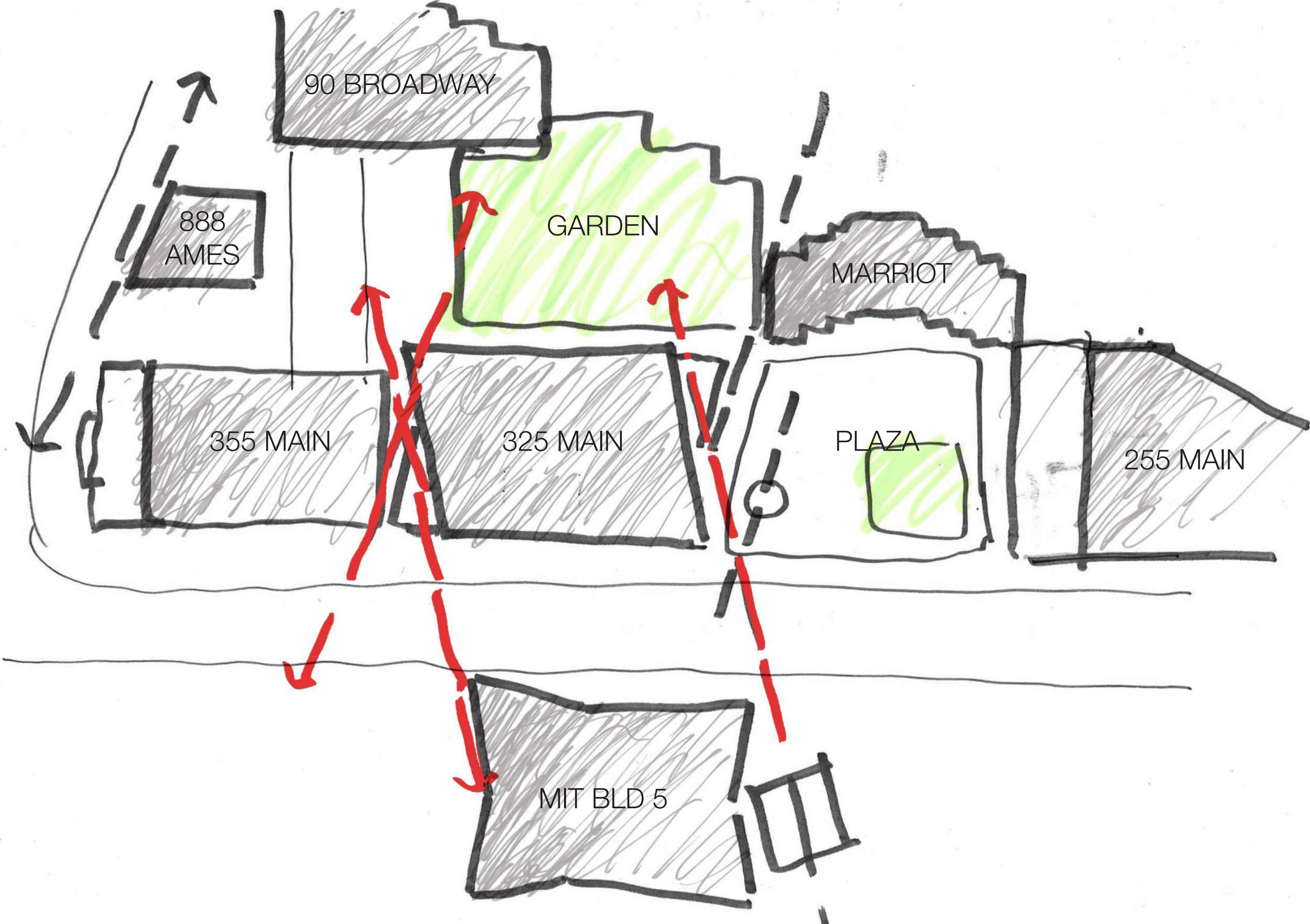

SITE DIAGRAM

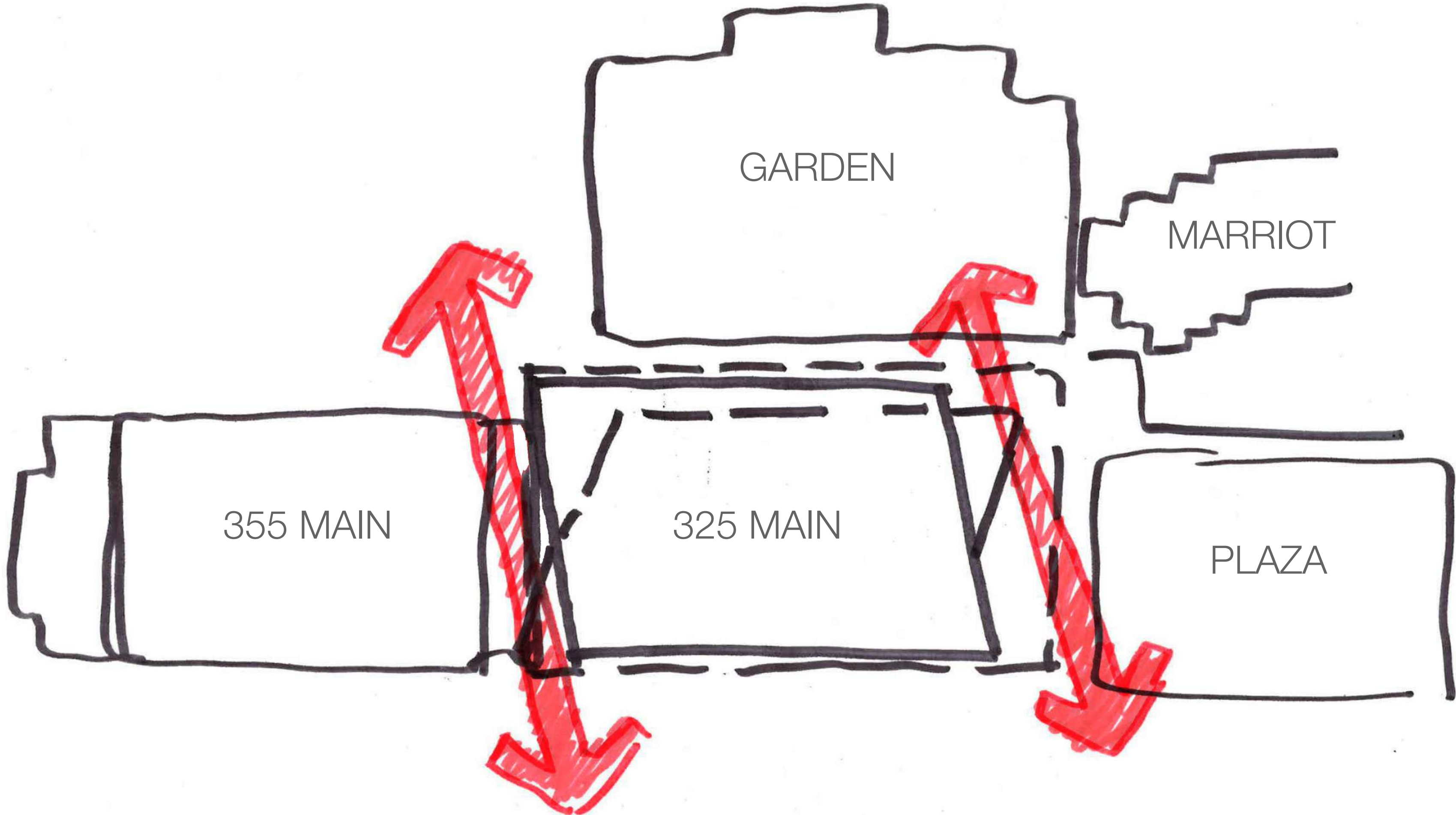

SITE DIAGRAM

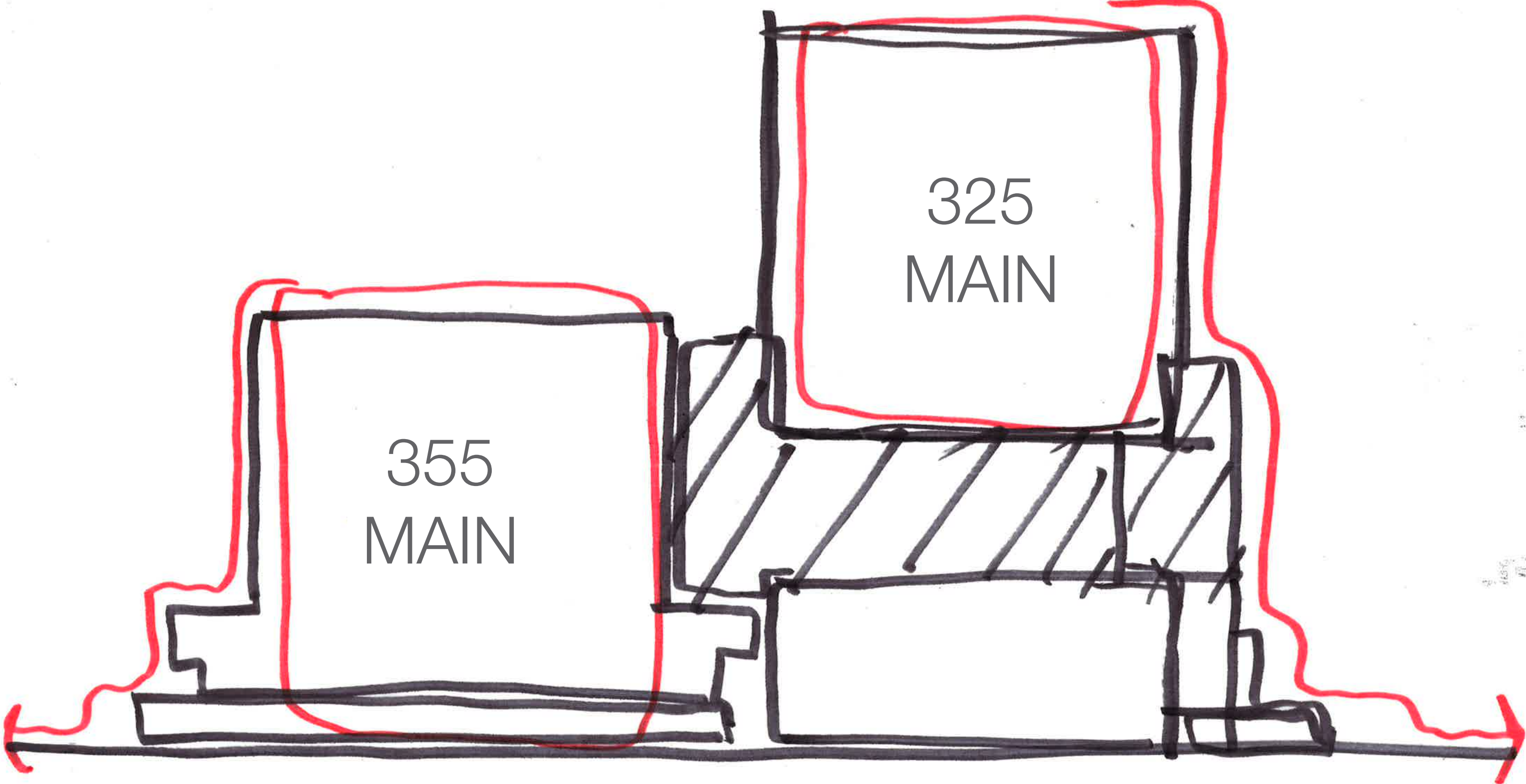

SITE DIAGRAM

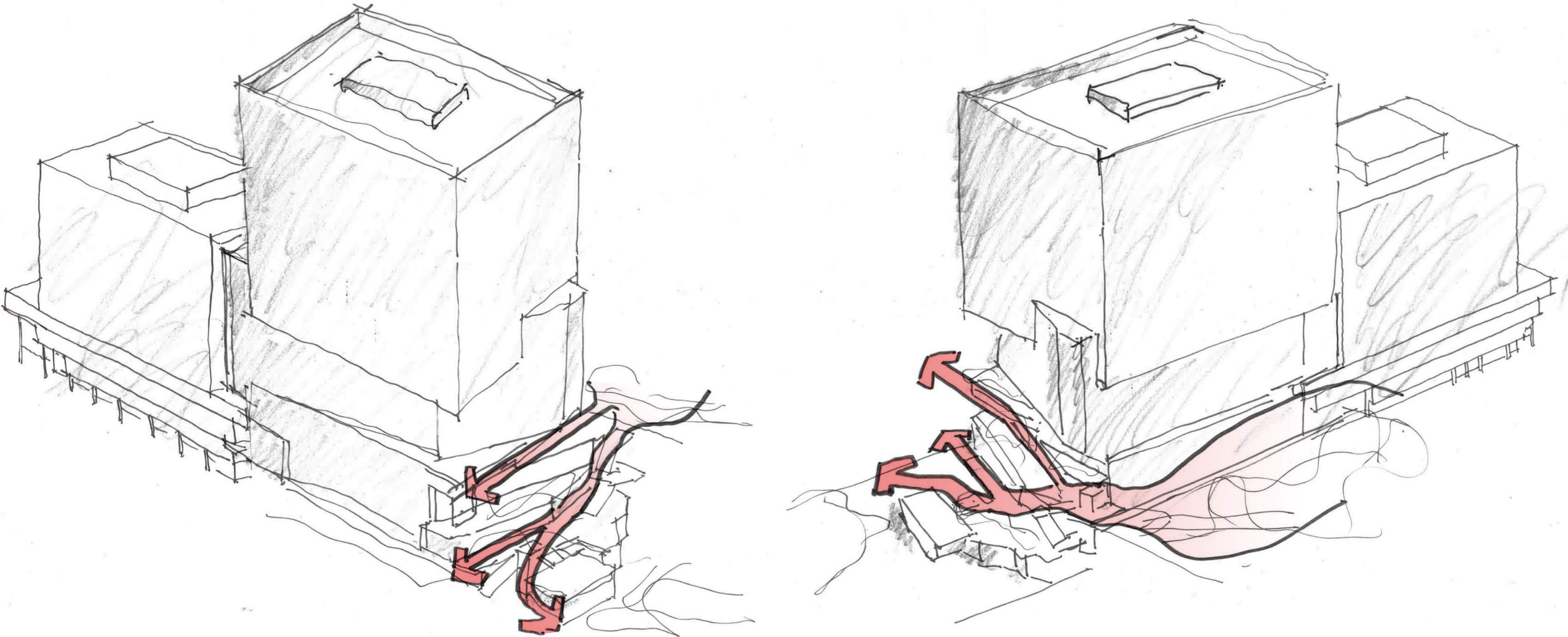

MASSING REFINEMENTS
3D VIEW FROM SOUTHEAST

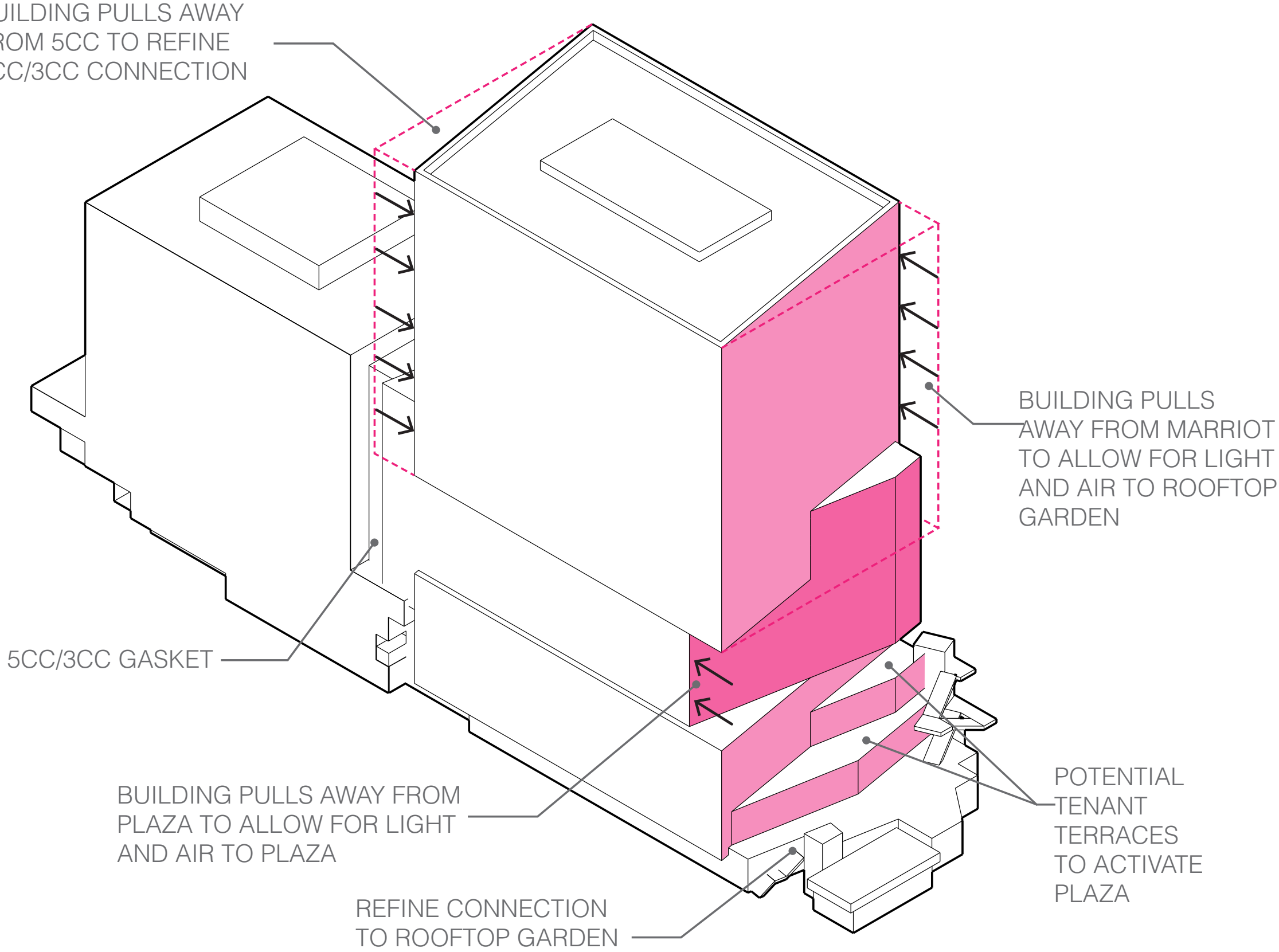
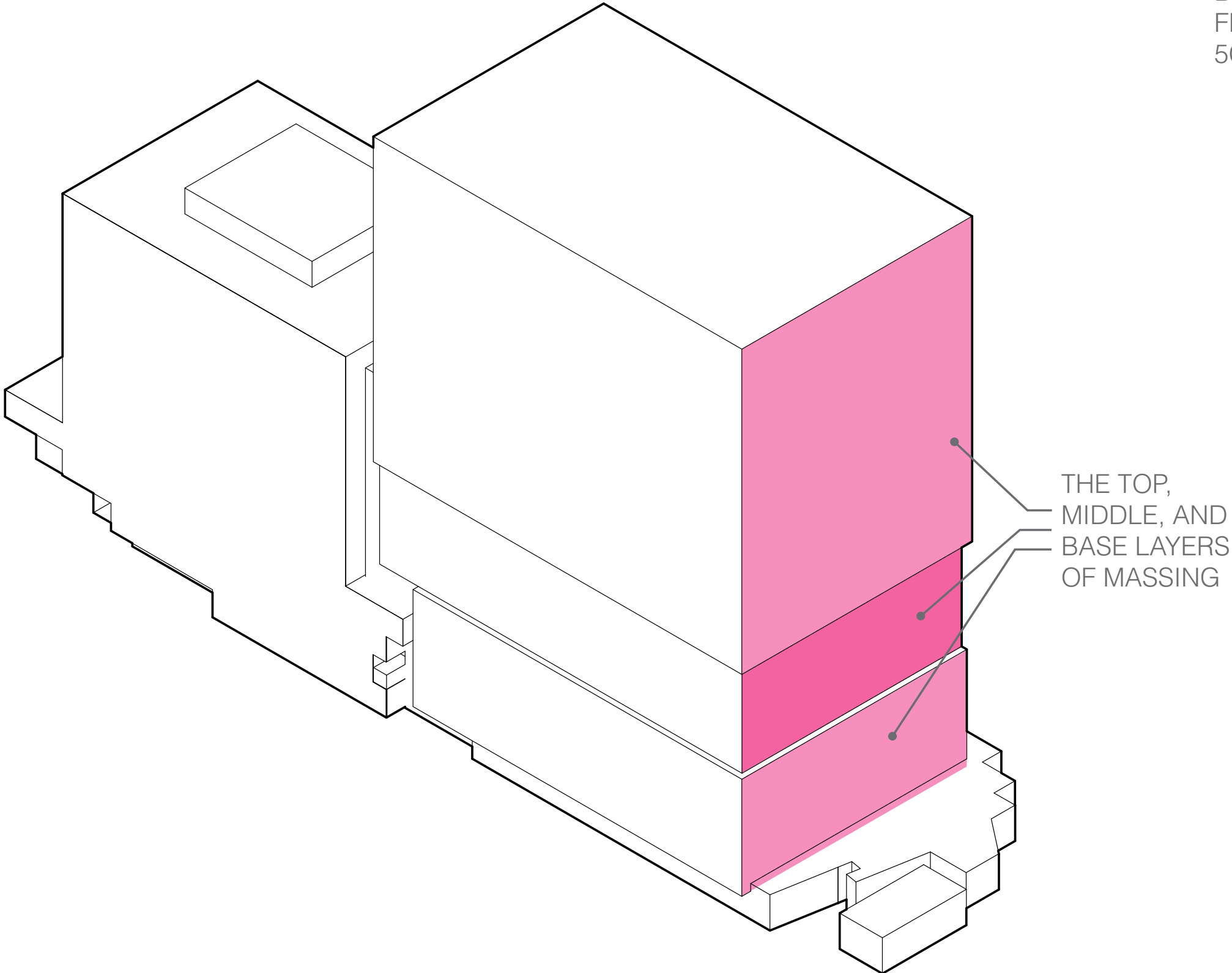

MASSING REFINEMENTS
3D VIEW FROM NORTHWEST

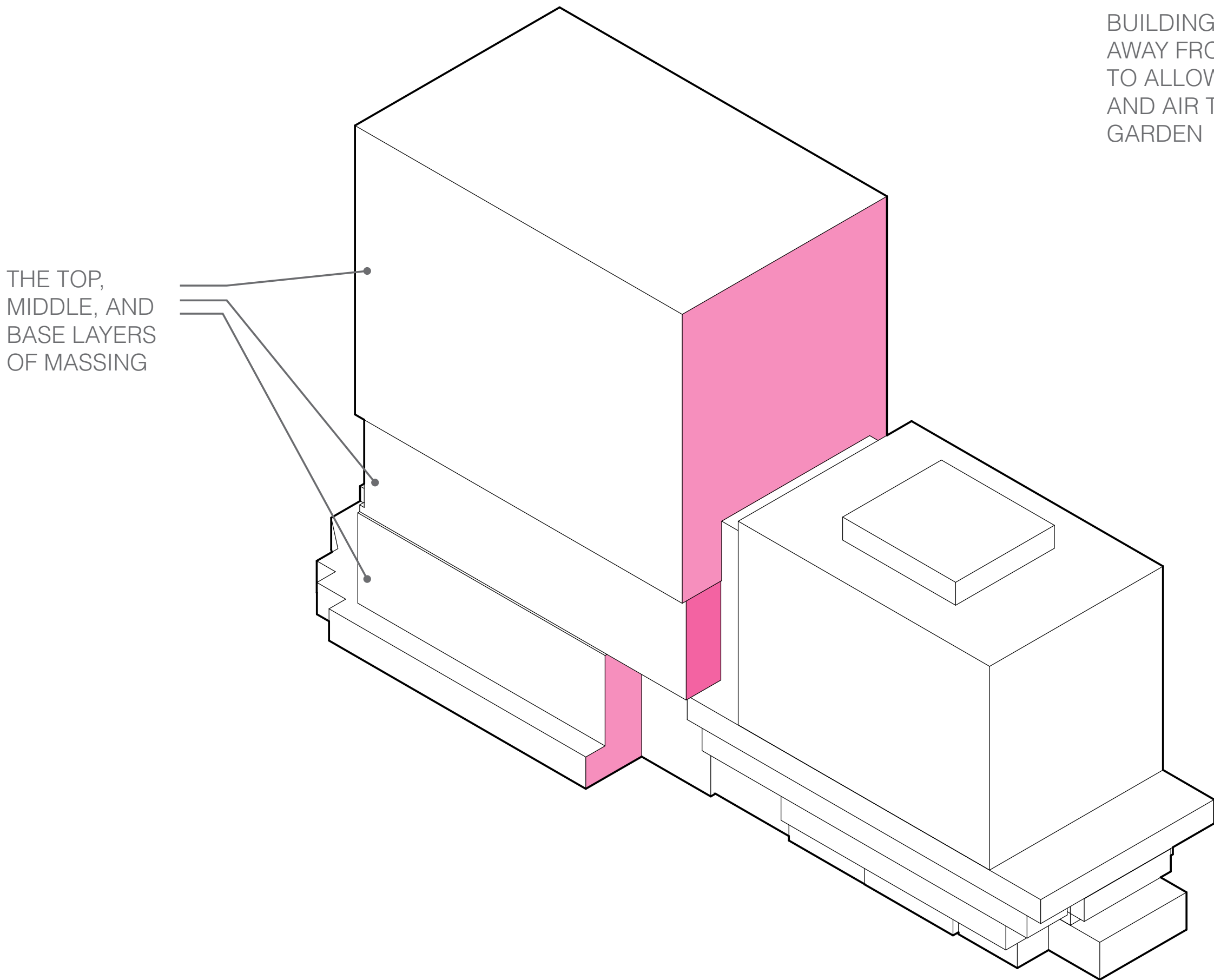

BUILDING PULLS AWAY FROM MARRIOT TO ALLOW FOR LIGHT AND AIR TO ROOFTOP GARDEN

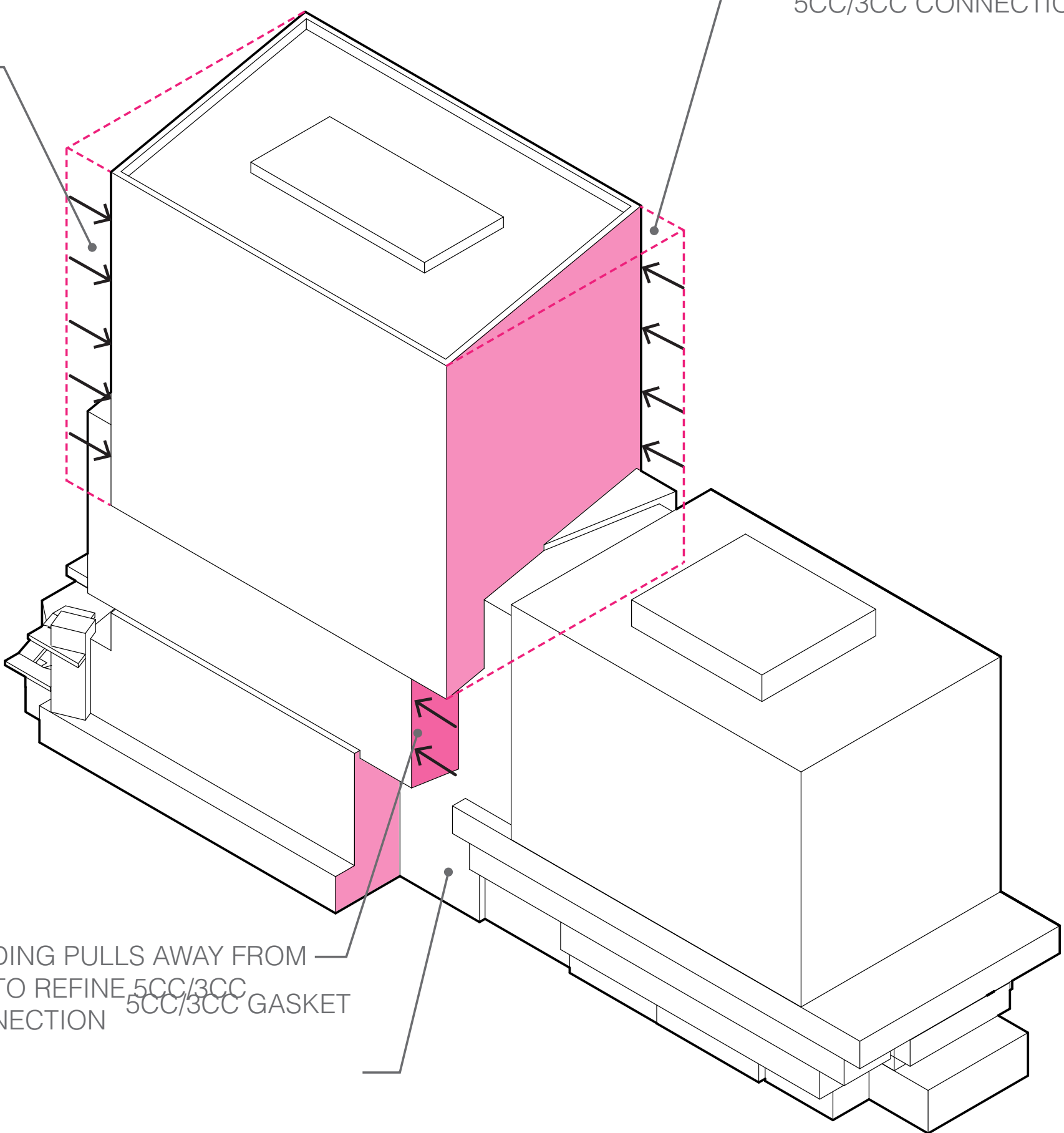

MASSING REFINEMENTS

SHIFTING GFA

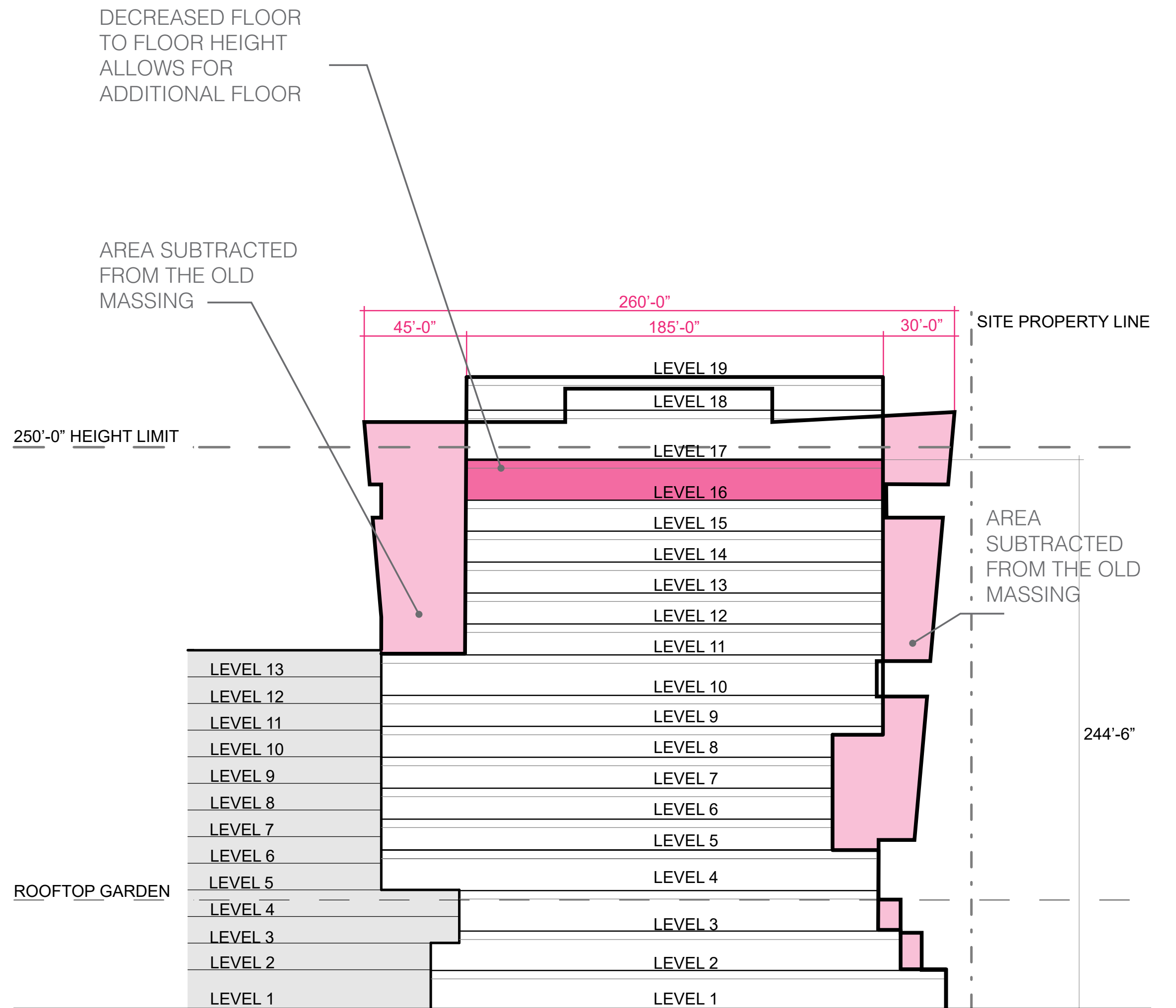
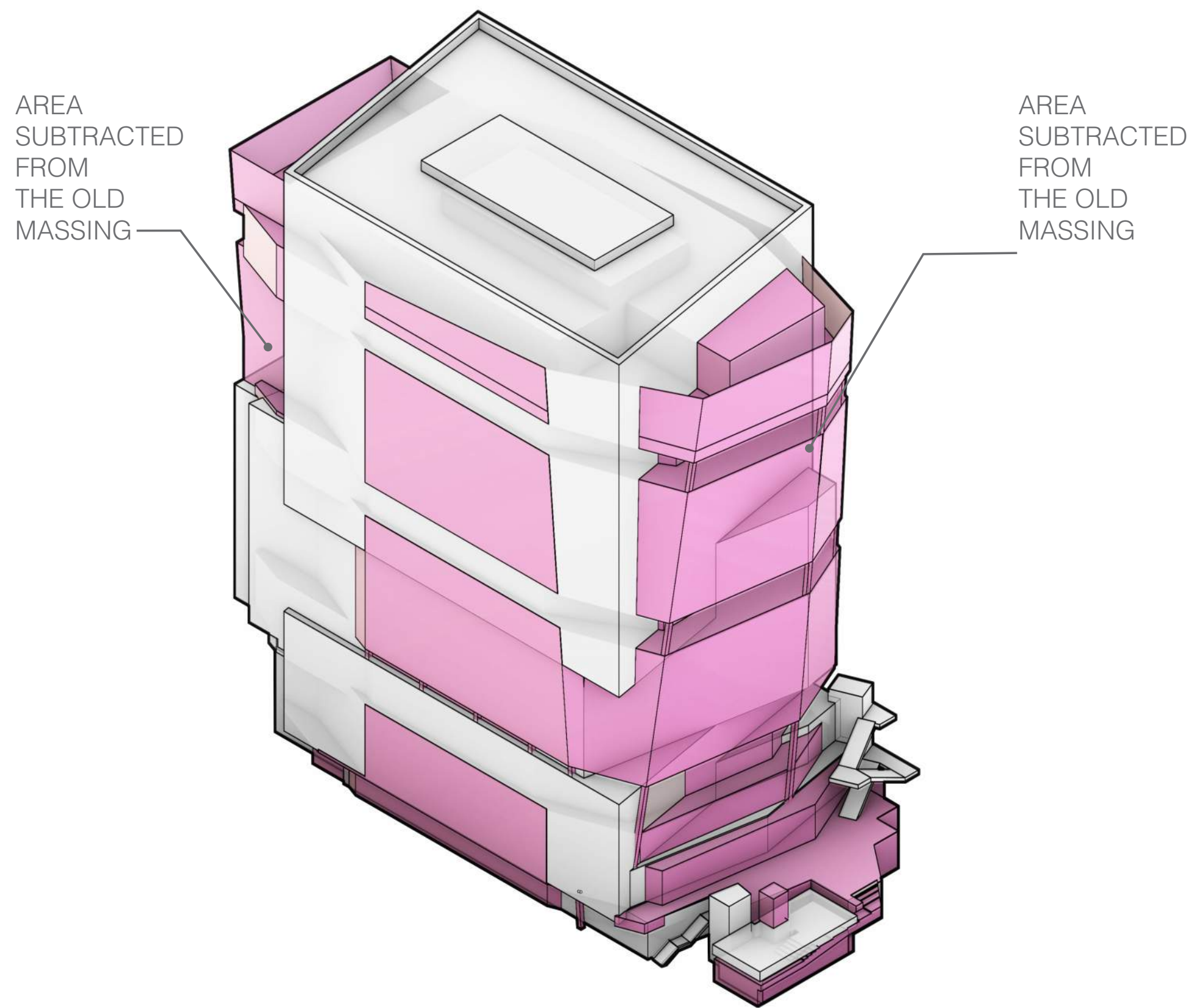

MASSING REFINEMENTS

SECTION COMPARISON

14'9" FLOOR TO FLOOR
 10'0" CEILING
 4'9" FLOOR PLENUM
 15 OCCUPIED FLOORS
 ABOVE GRADE
 239'3" TO MAIN ROOF

13'9" FLOOR TO FLOOR
 10'0" CEILING
 3'9" FLOOR PLENUM
 16 OCCUPIED FLOORS
 ABOVE GRADE
 244'6" TO MAIN ROOF

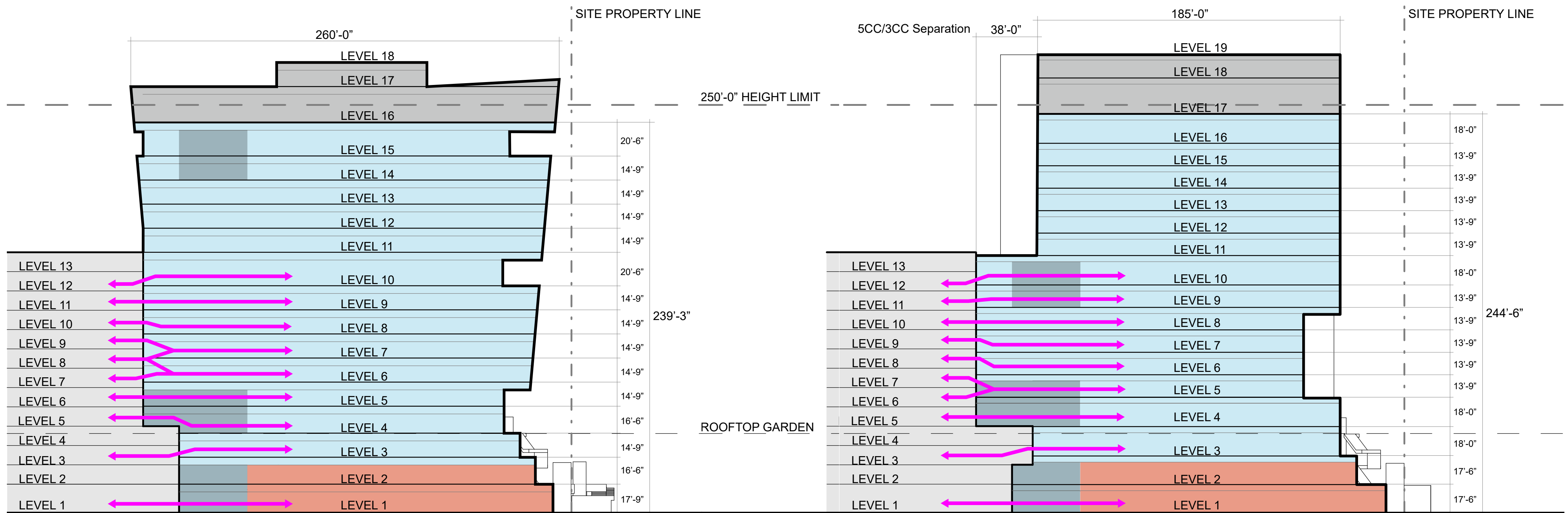

SEPTEMBER 06 2018

OCTOBER 17 2018

MASSING REFINEMENTS

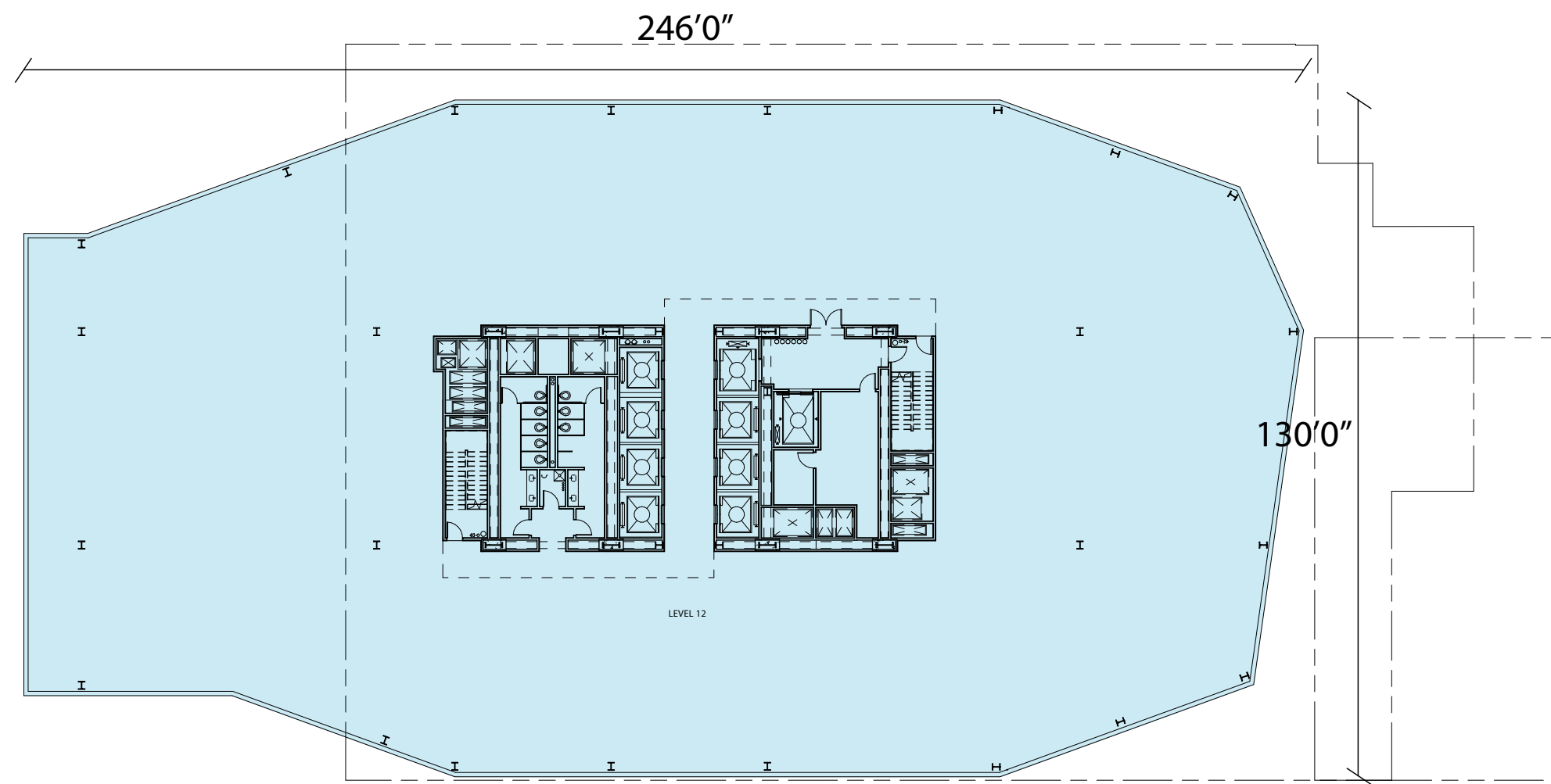

Level 12 - 27K GFA Office

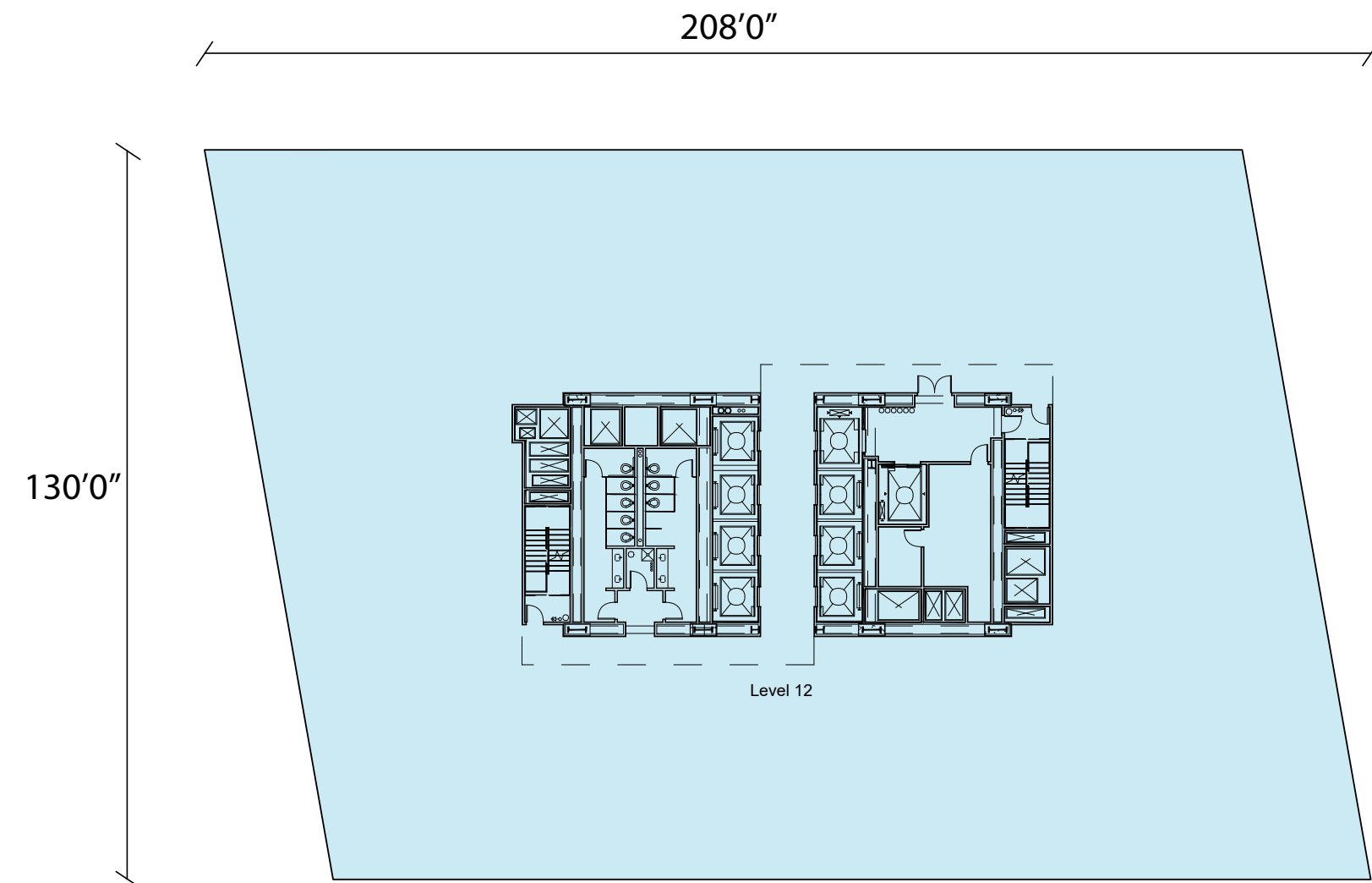

Level 12 - 23K GFA Office

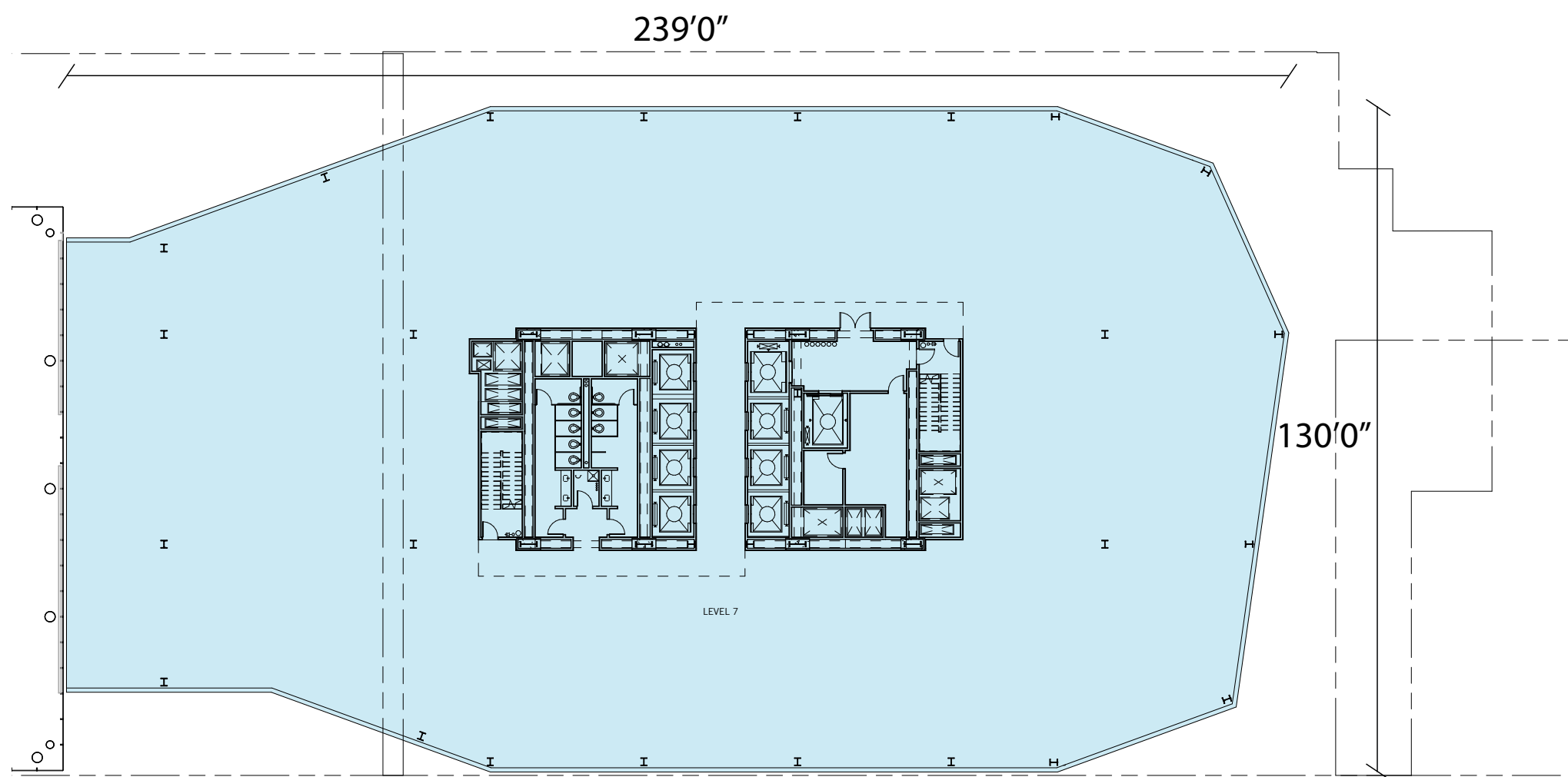

Level 7 - 26K GFA Office

SEPTEMBER 06 2018

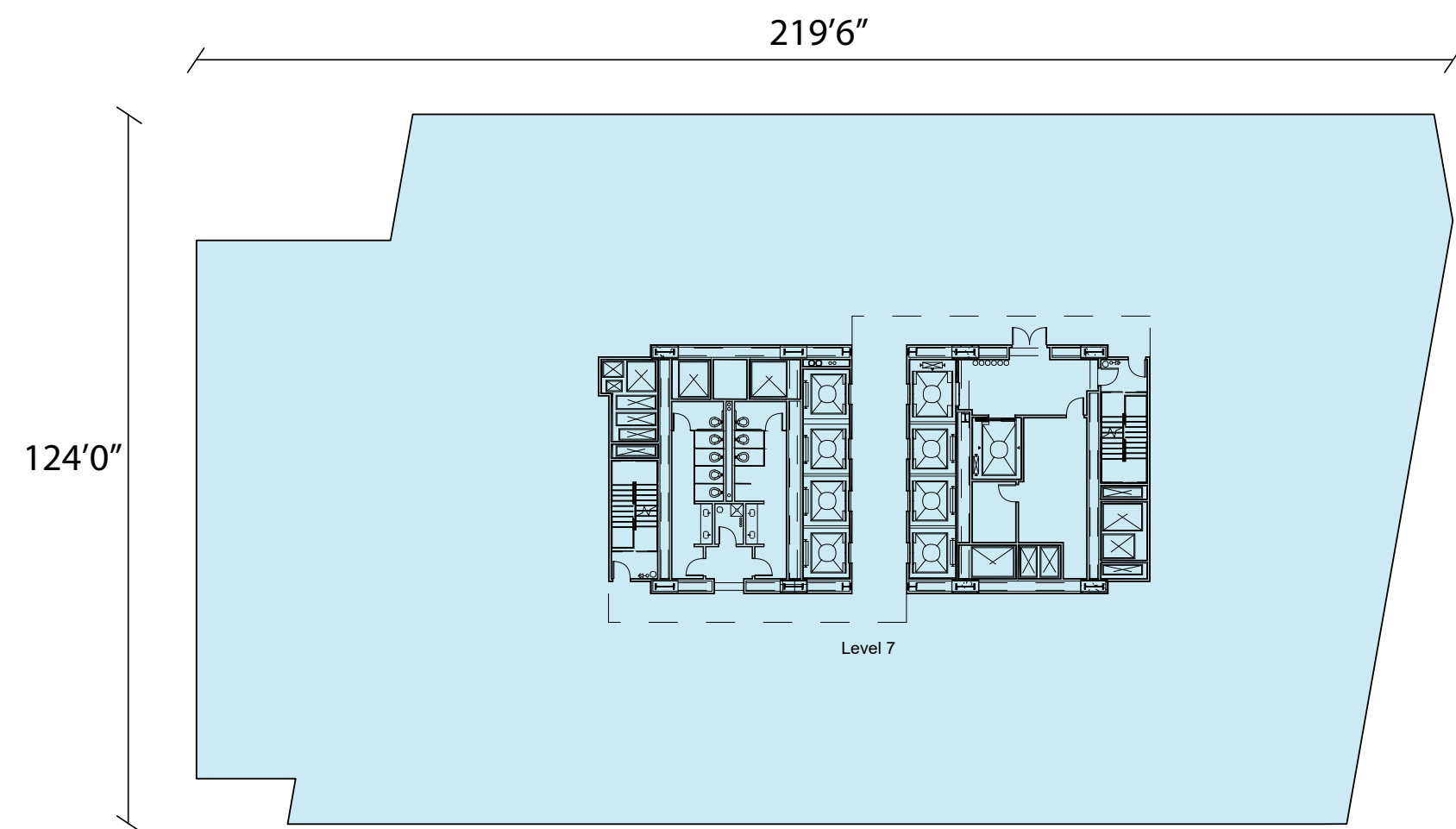

Level 7 - 24K GFA Office

OCTOBER 17 2018

Floor Comparison

MASSING REFINEMENTS/BALCONIES

