

TOWER MASSING/ARTICULATION

URBAN CONTEXT

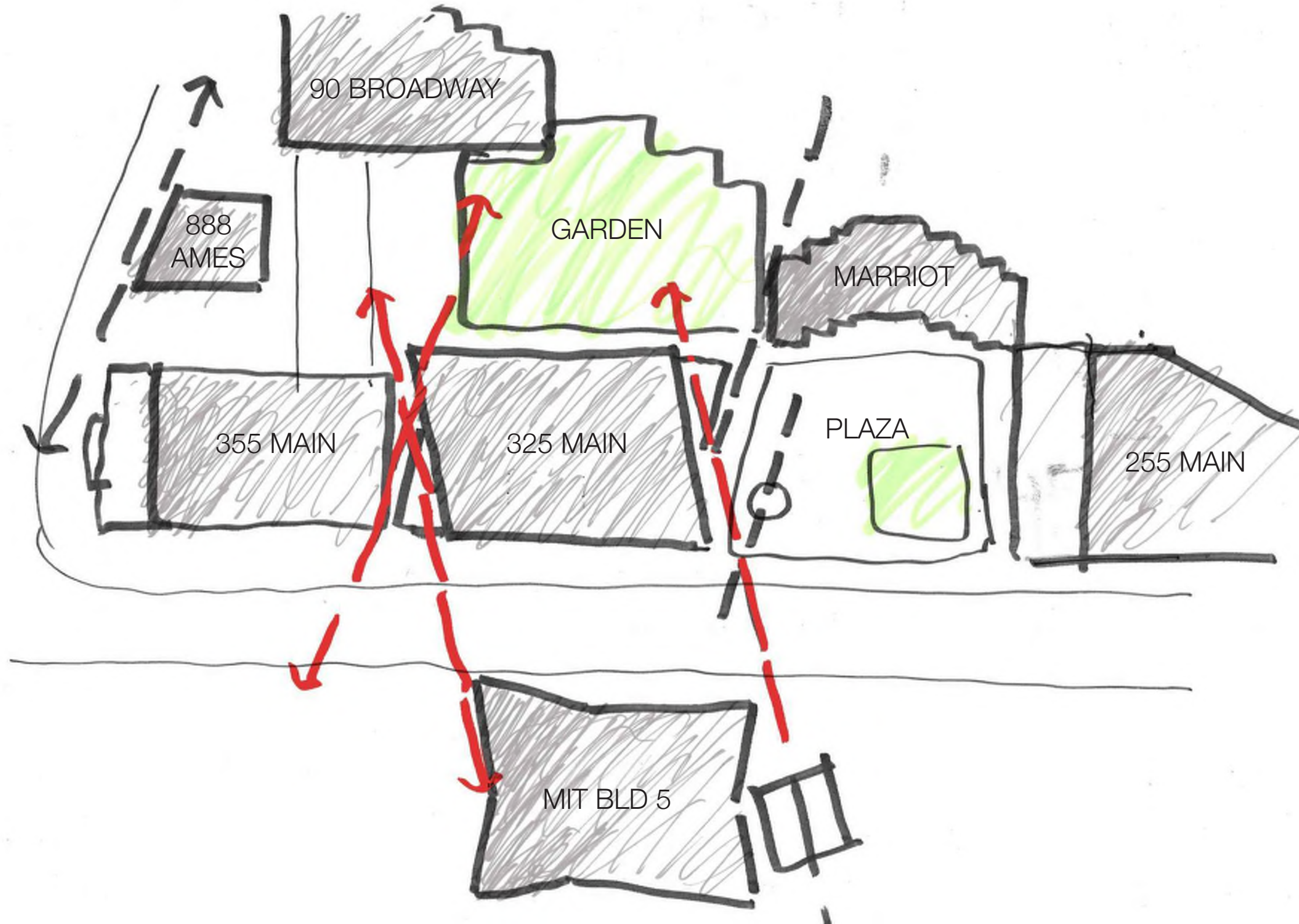

MASSING REFINEMENTS

SHIFTING GFA

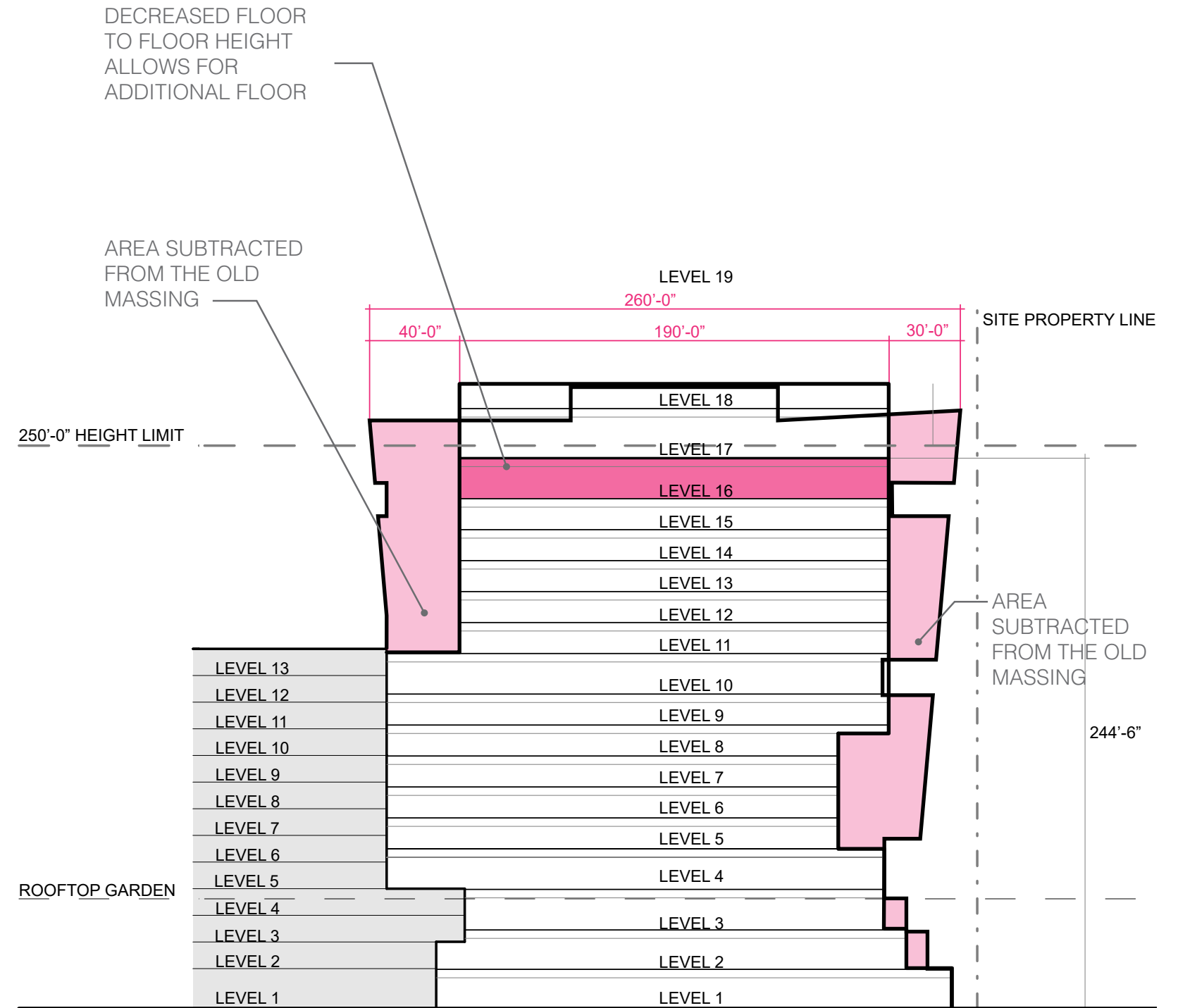
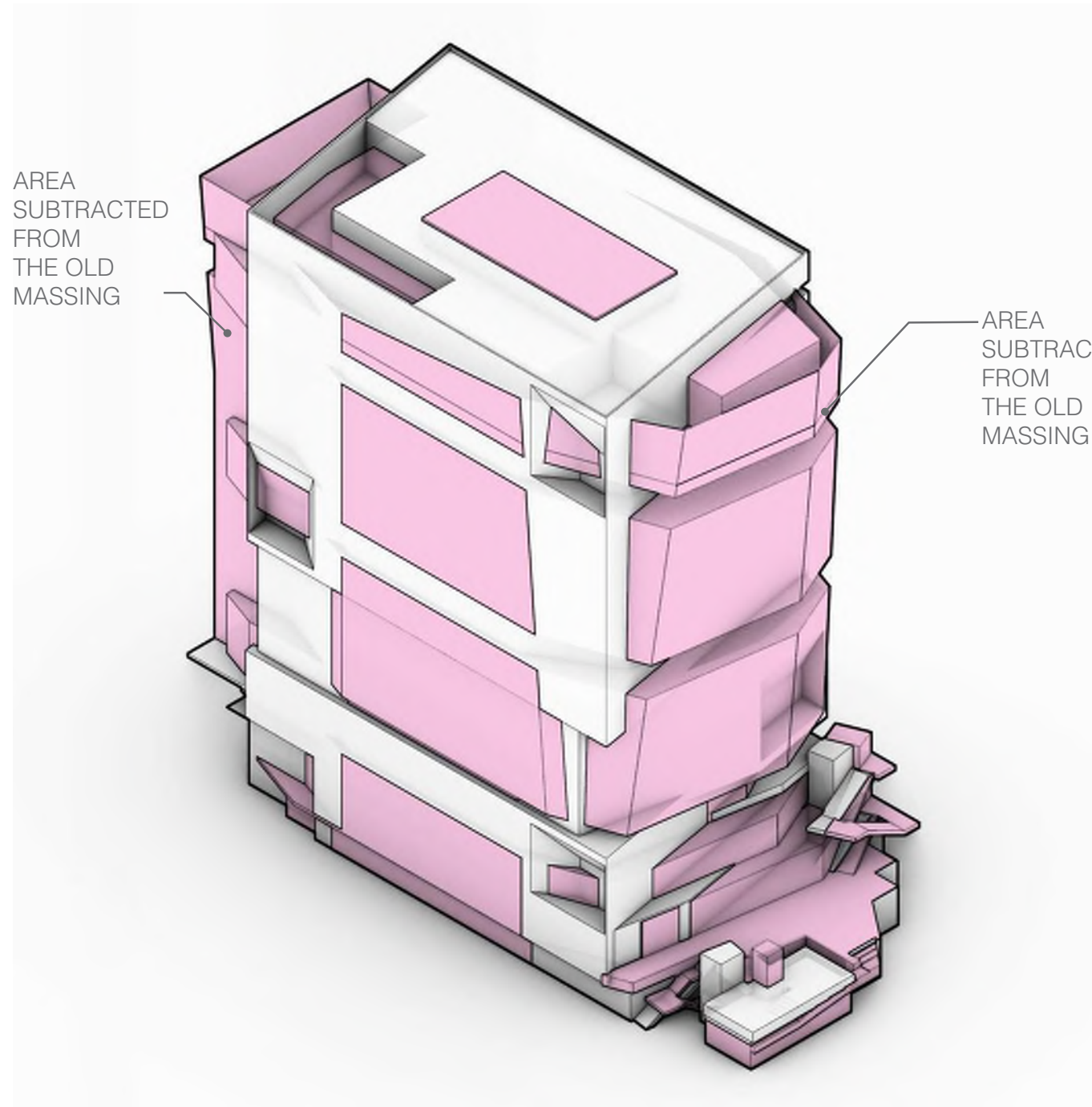

MASSING REFINEMENTS

MASSING & SCALE

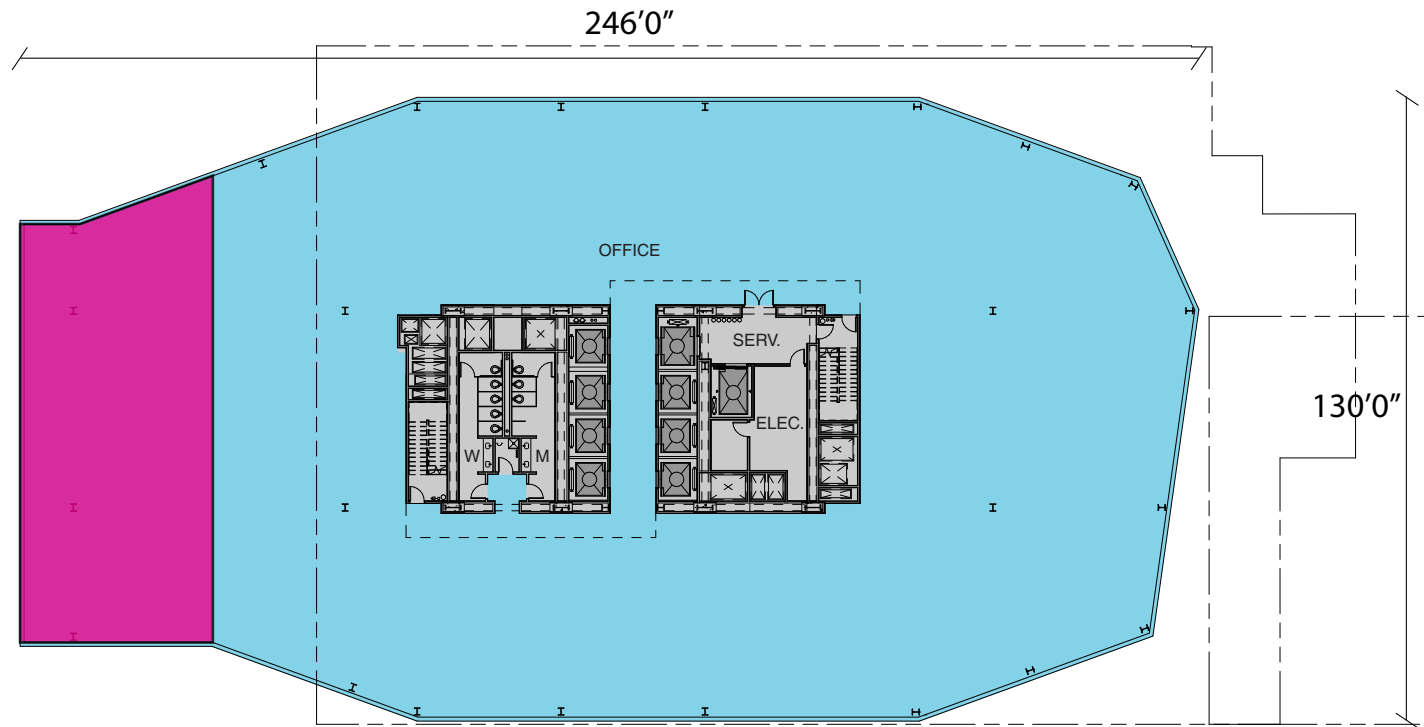

Level 12 - 27K GFA Office

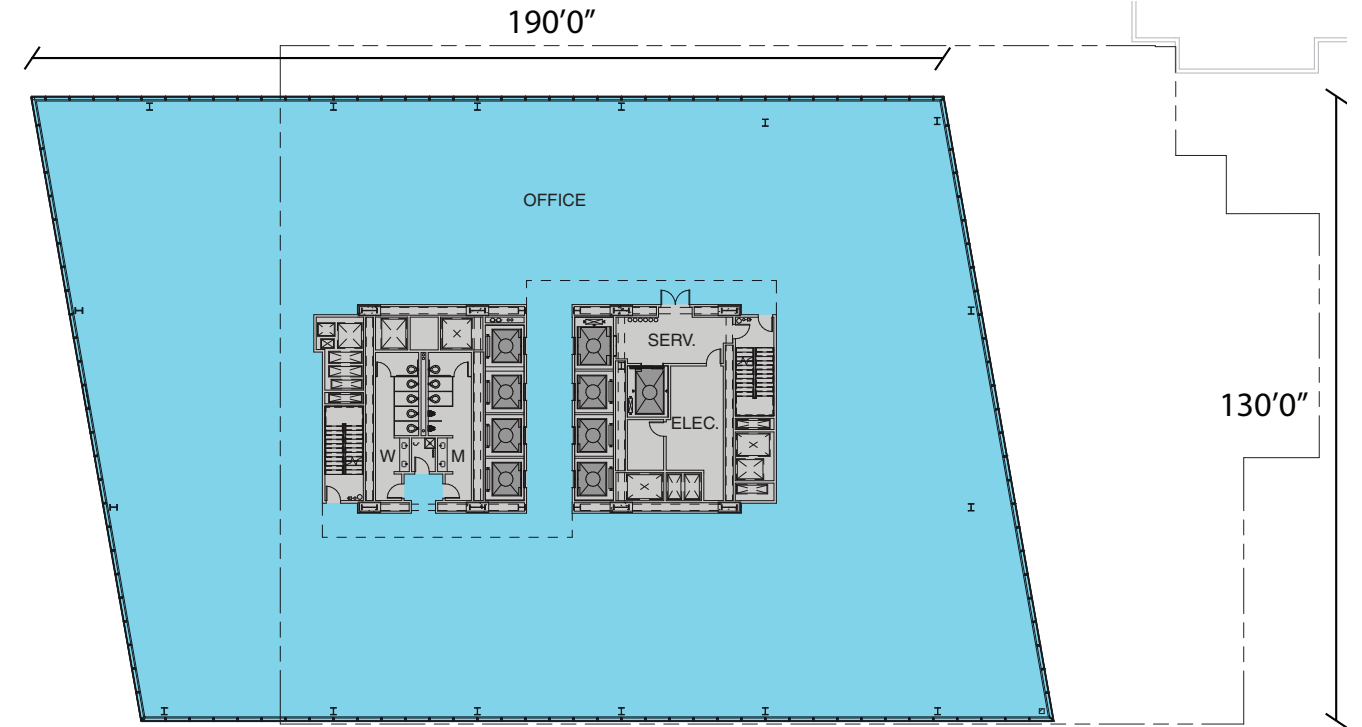

Level 12 - 23.5K GFA Office

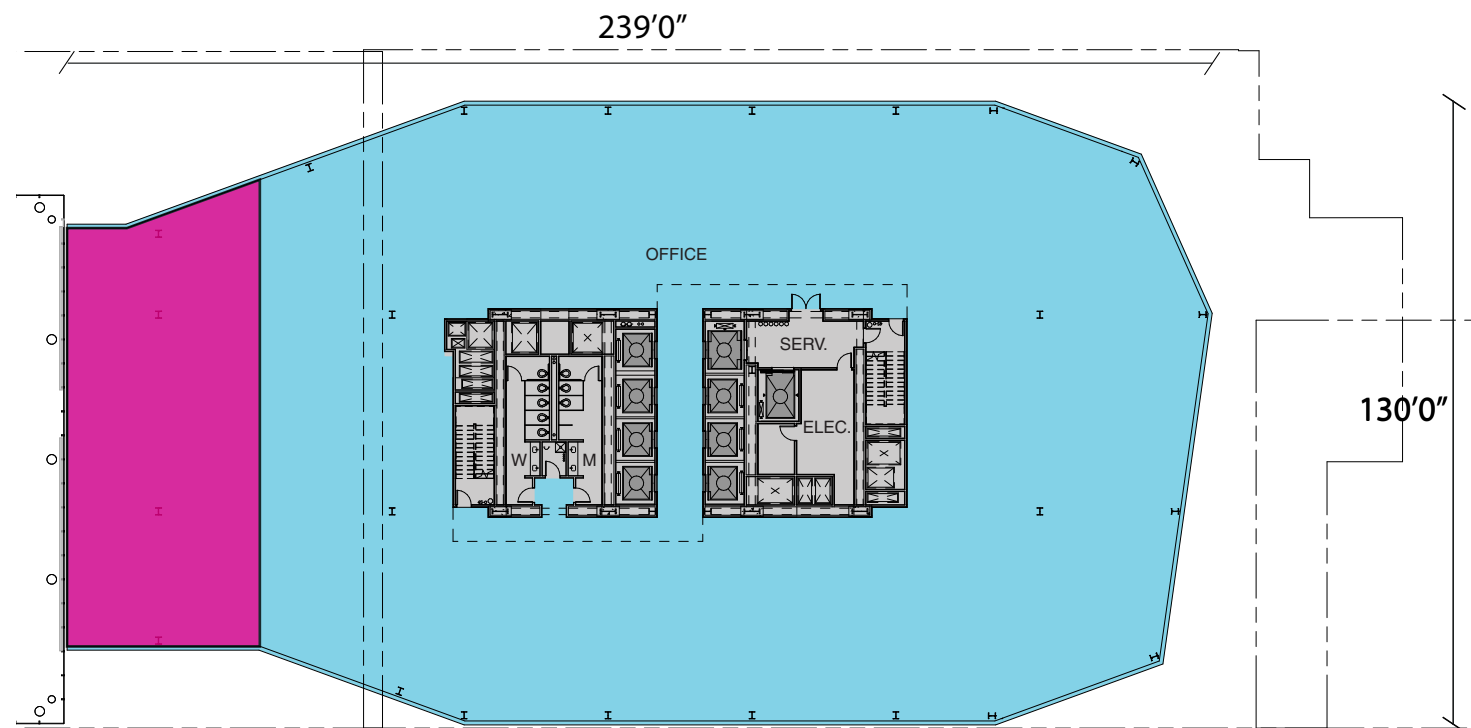

Level 7 - 26K GFA Office

SEPTEMBER 06 2018

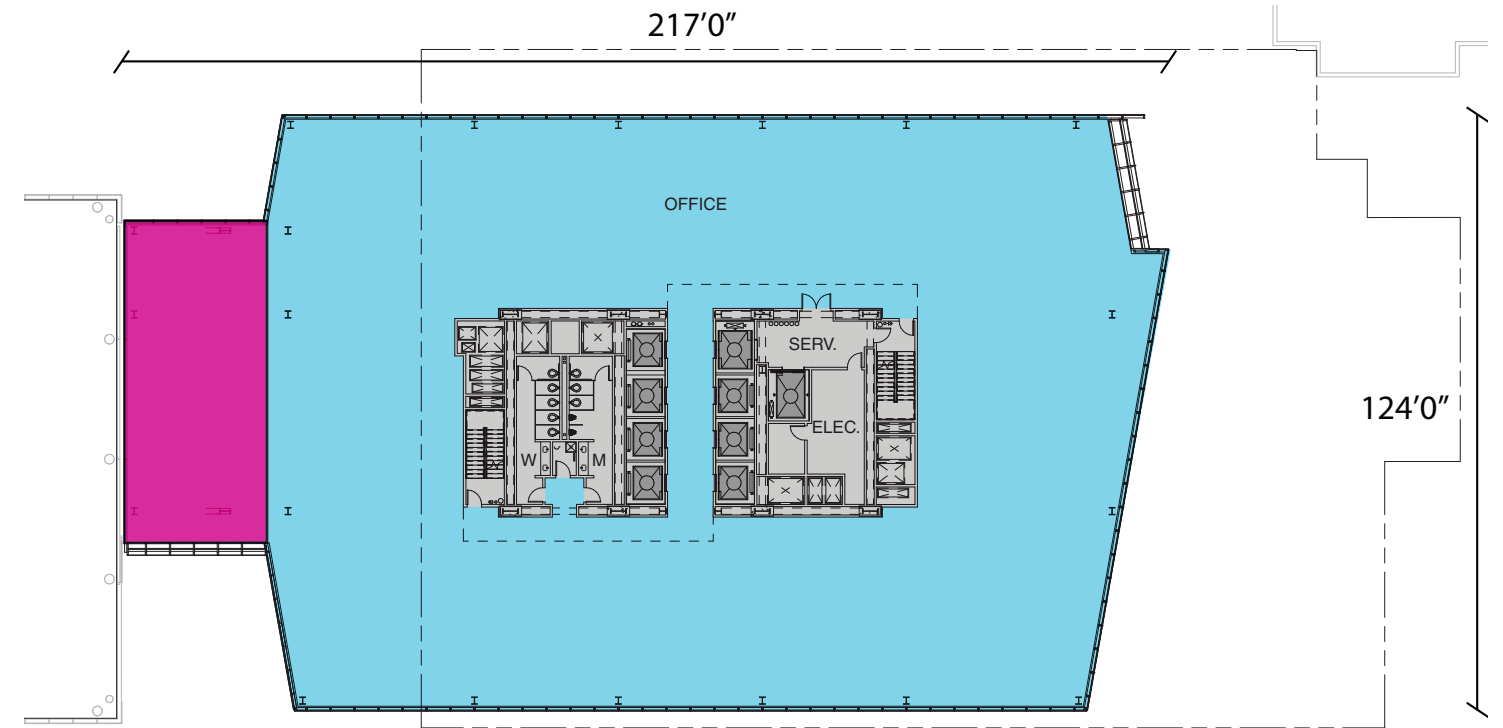

Level 7 - 24K GFA Office

DECEMBER 04 2018

MASSING REFINEMENT

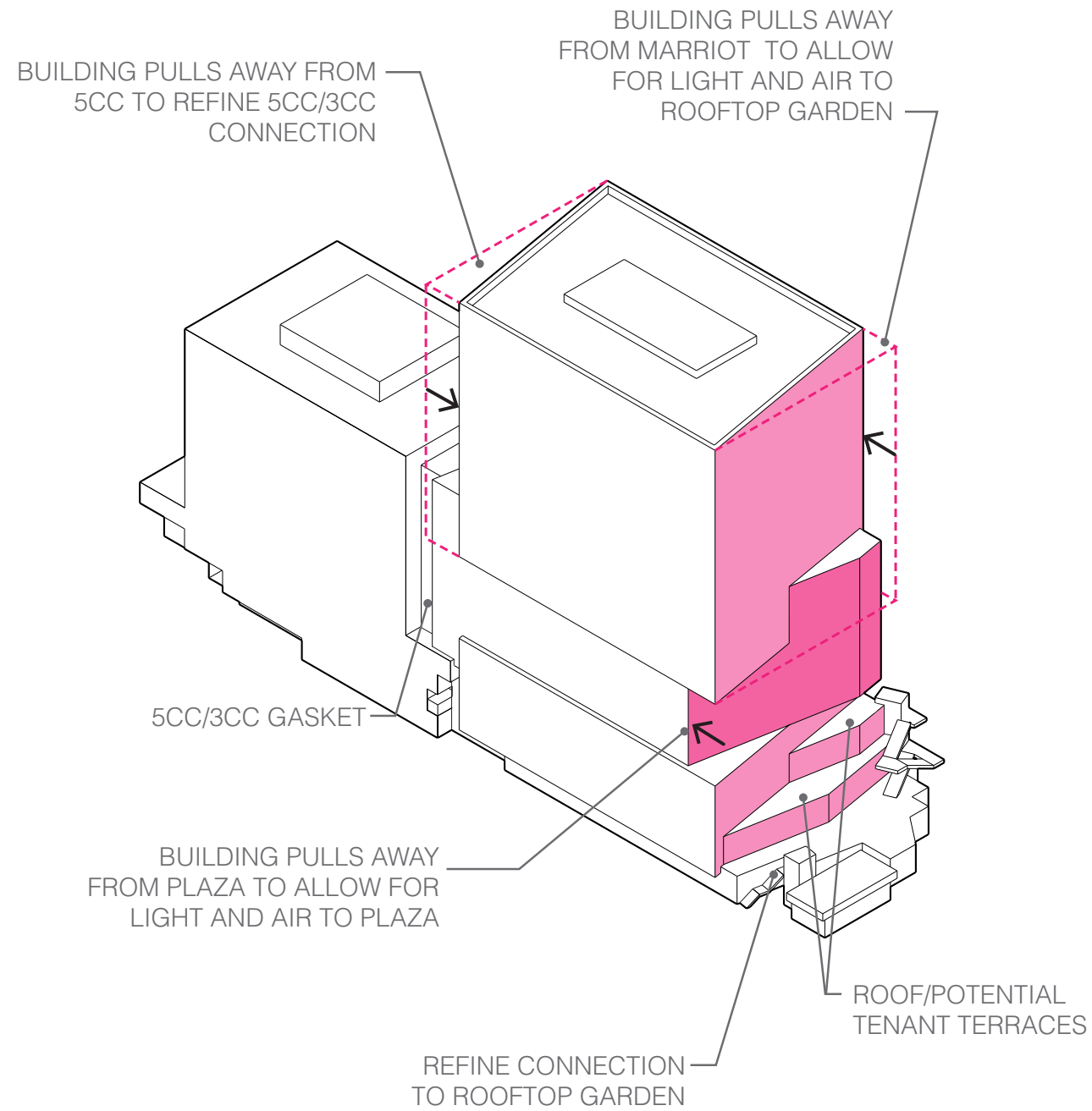

NOVEMBER 02 2018

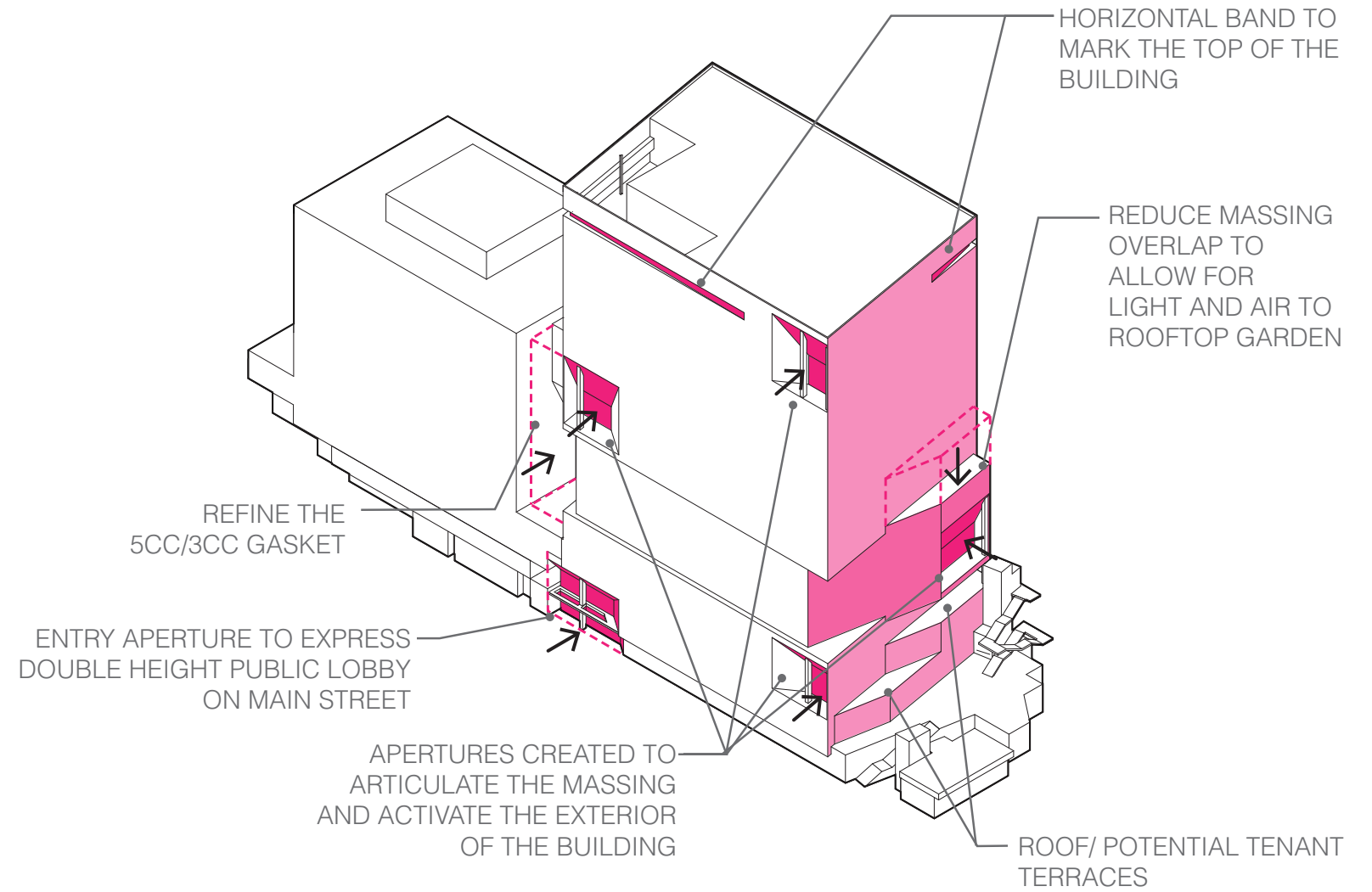

DECEMBER 04 2018

MASSING REFINEMENT

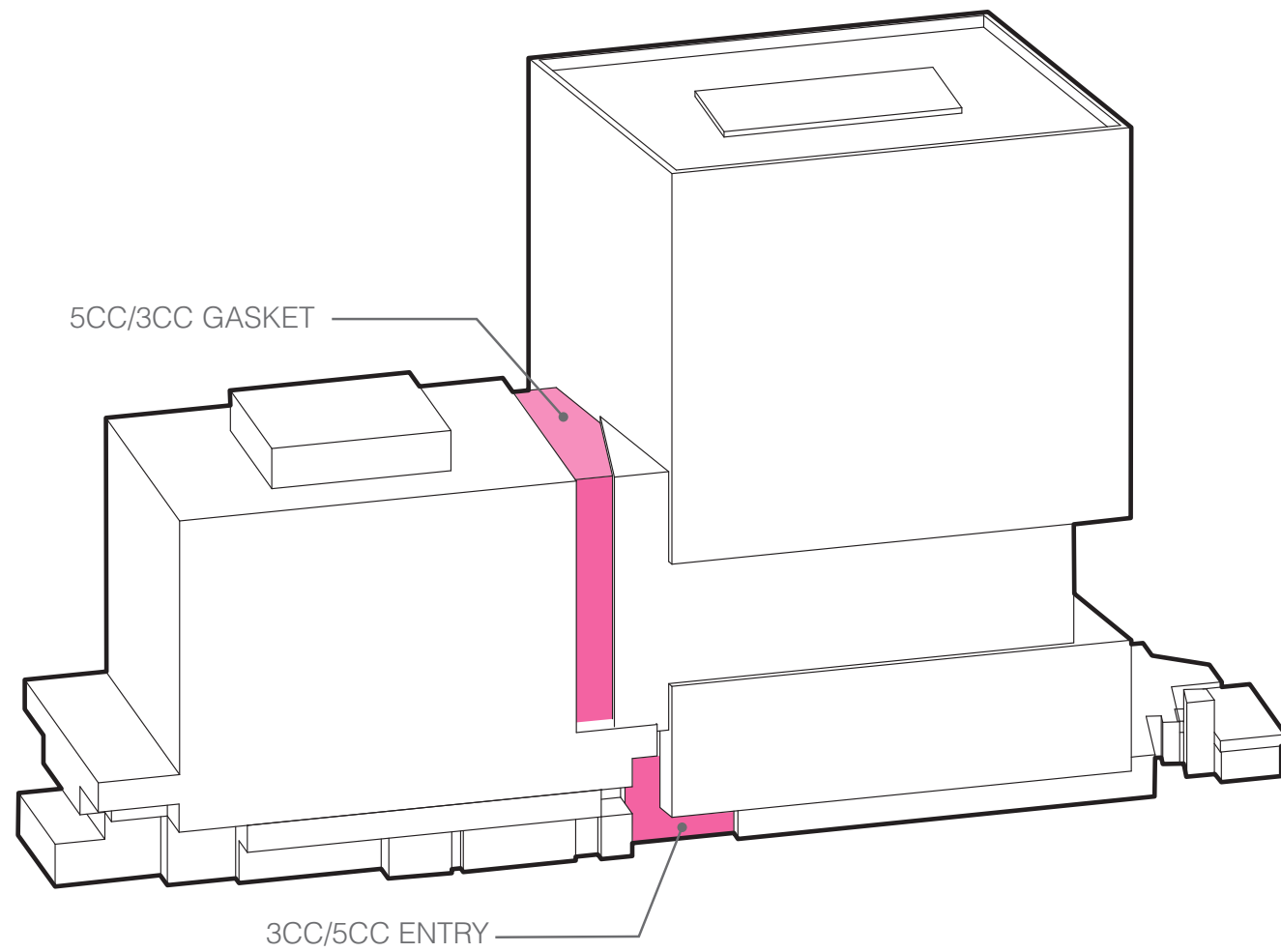

NOVEMBER 02 2018

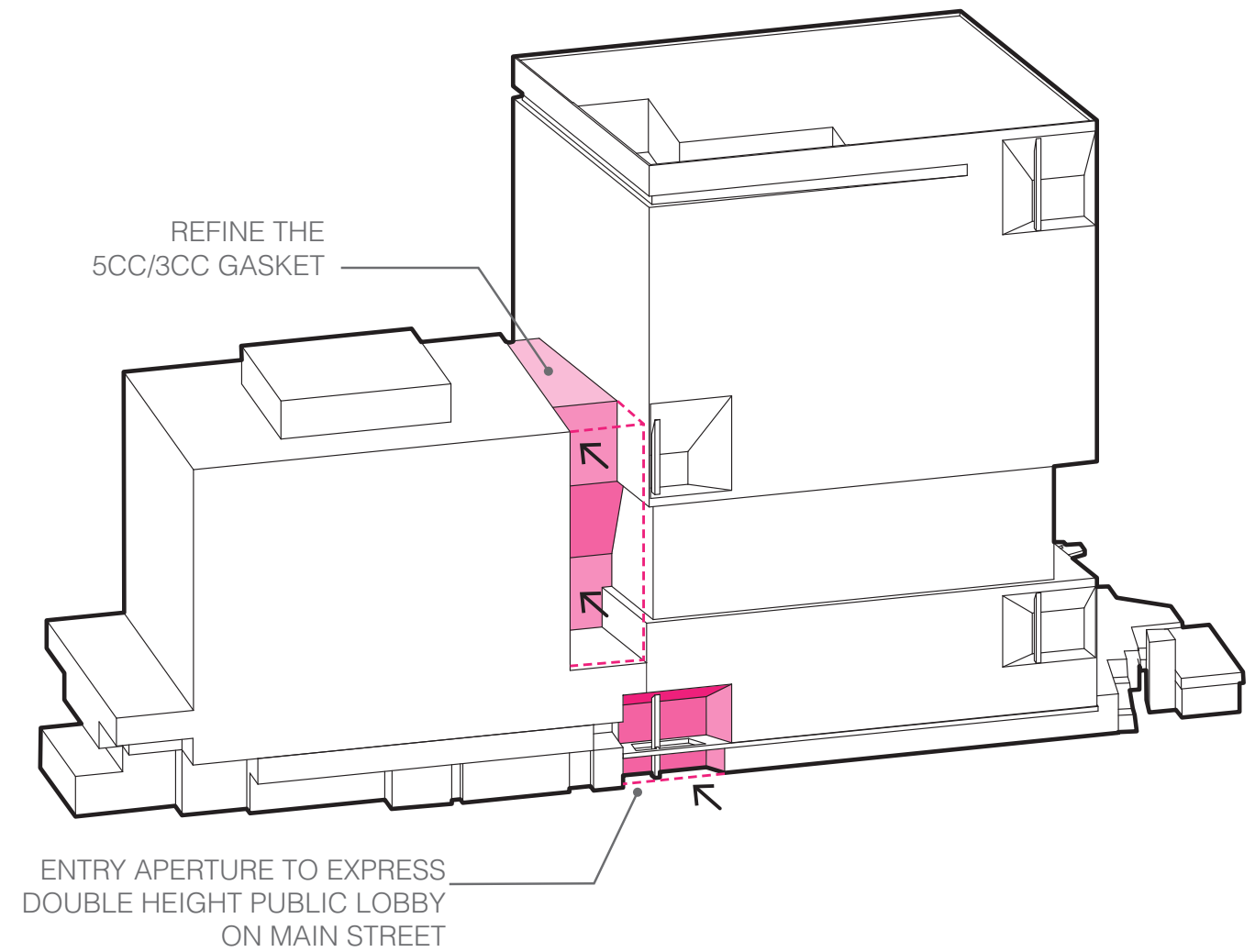

DECEMBER 04 2018

MASSING REFINEMENT

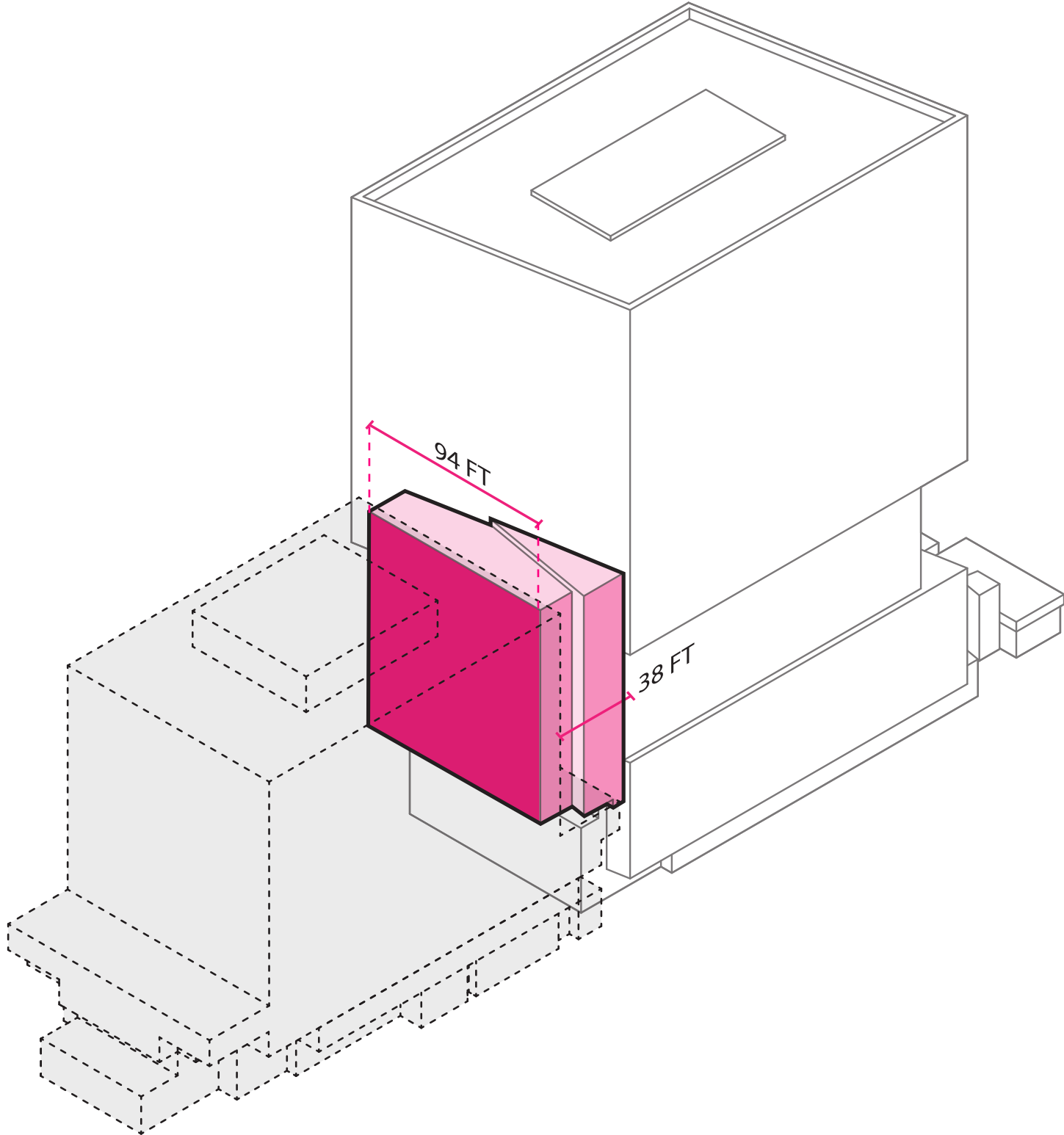

MASTERPLAN SUBMISSION

MASSING REFINEMENT

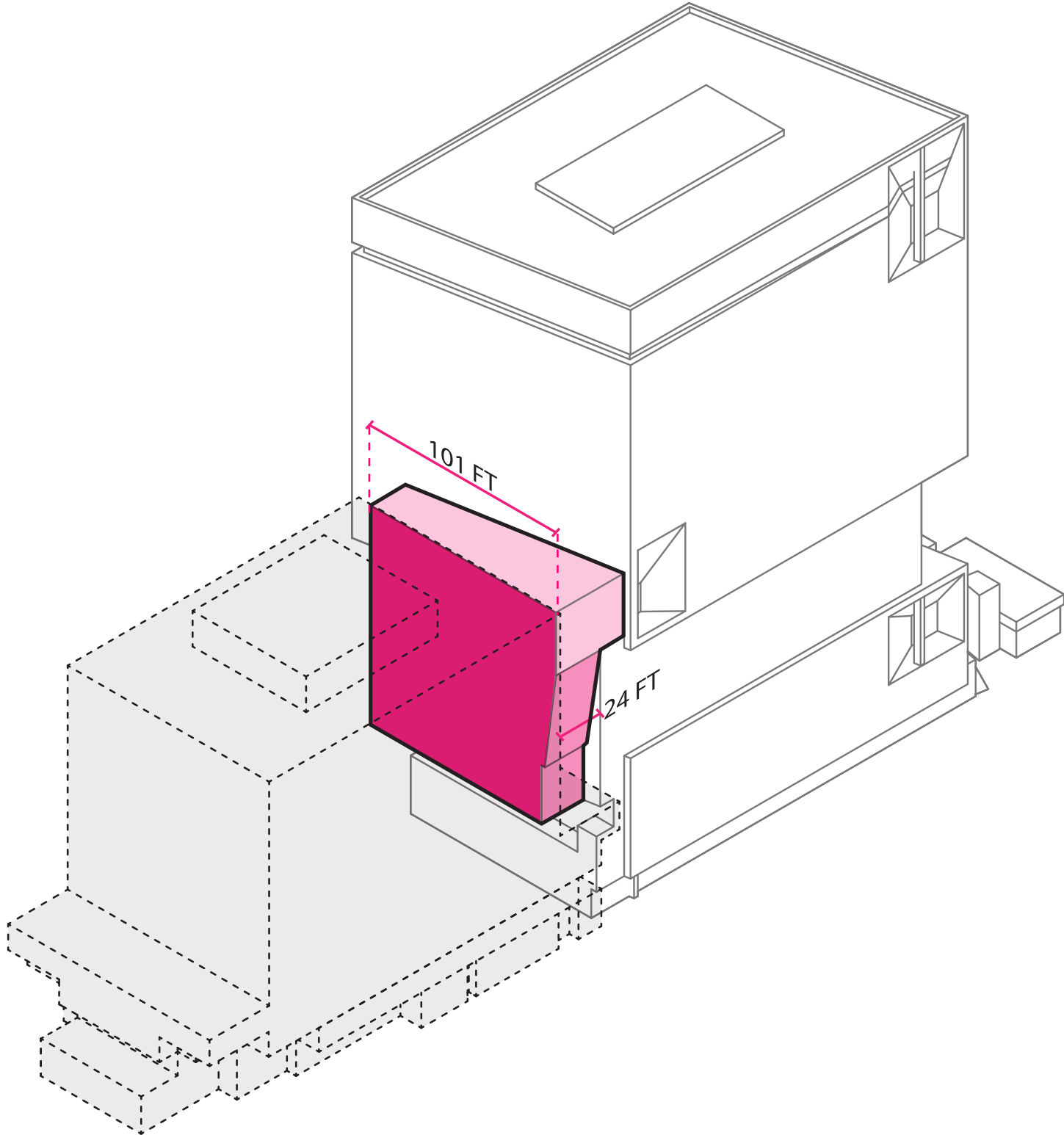

MASSING REFINEMENT

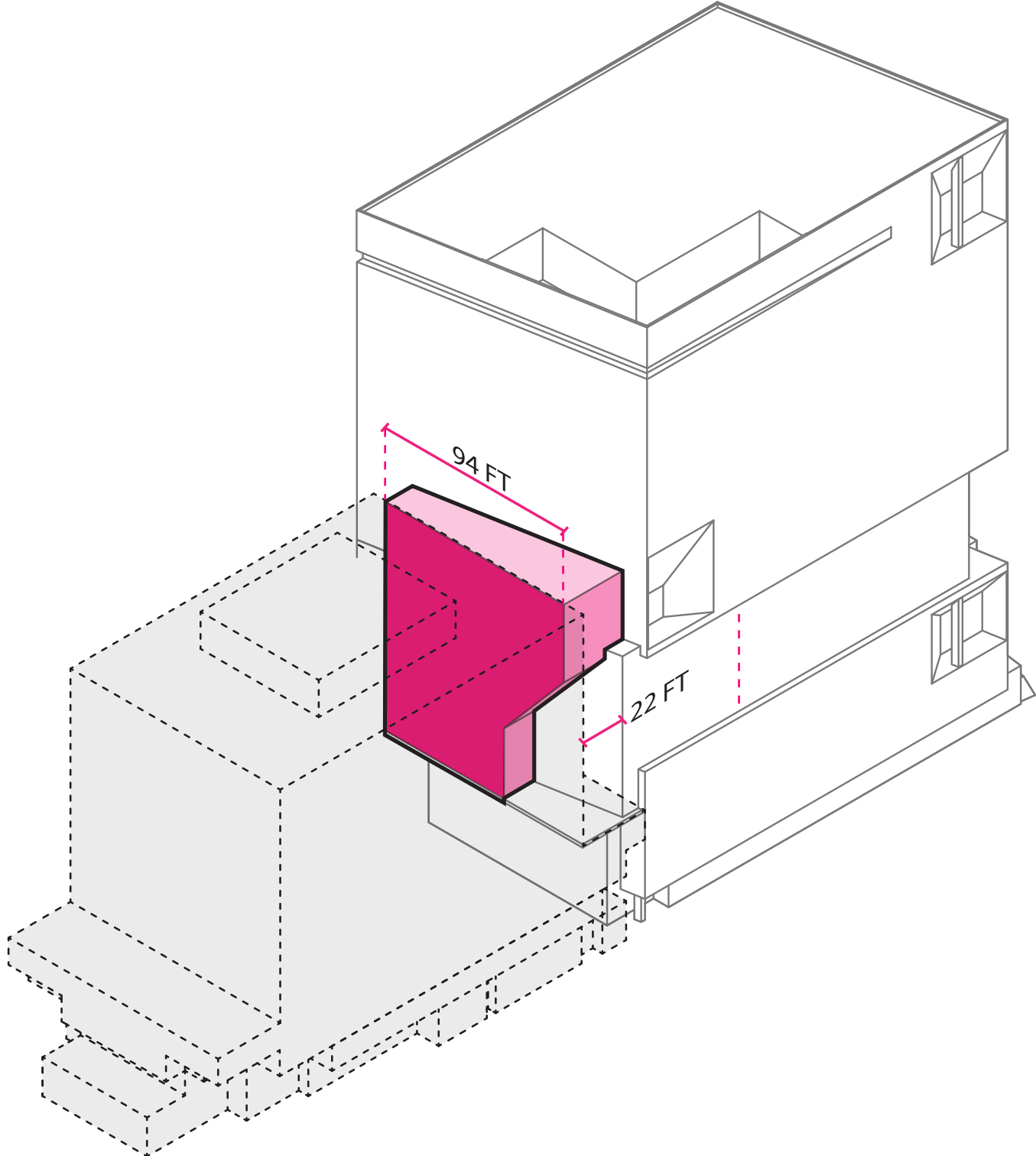

MASSING REFINEMENT

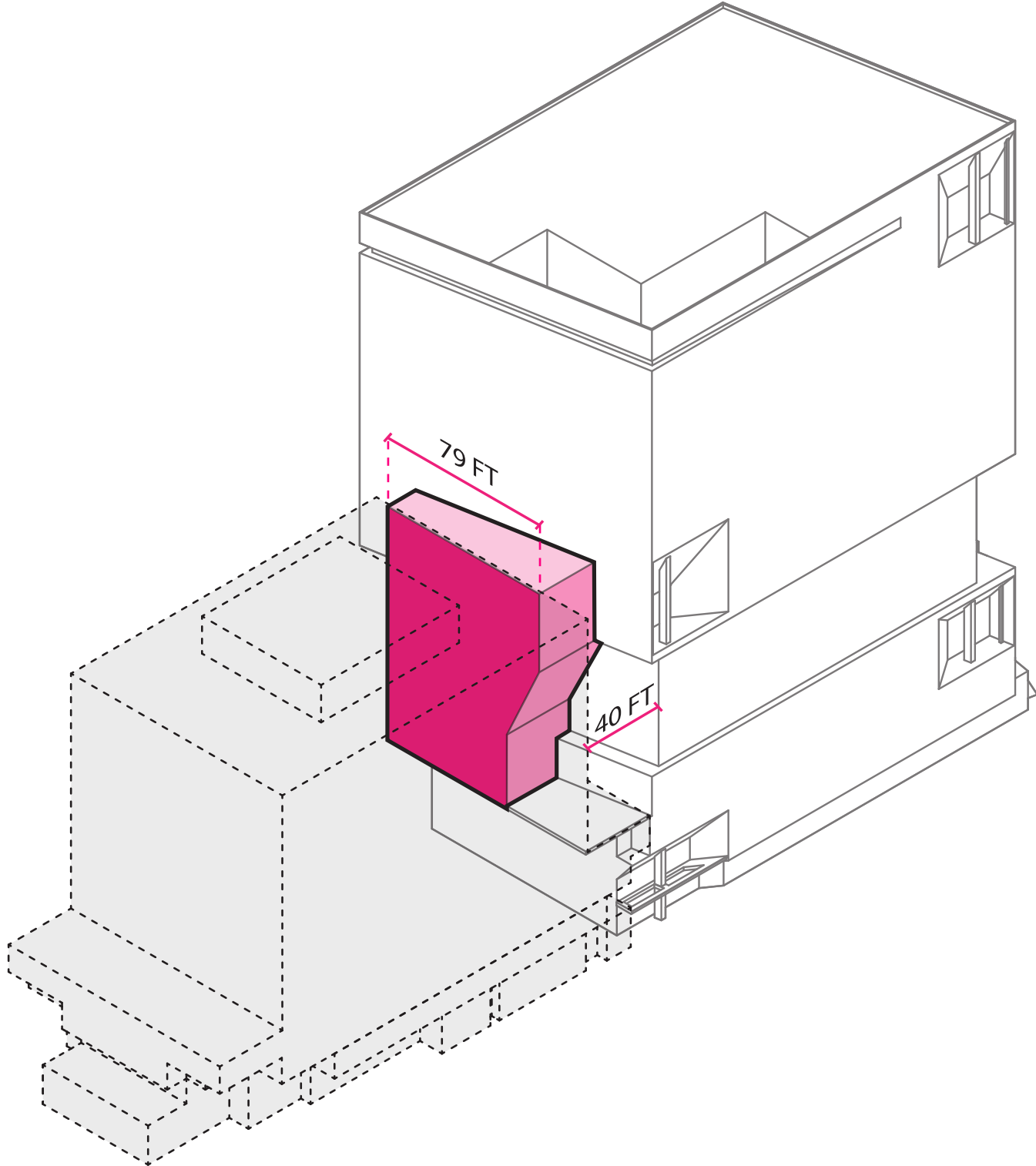

DECEMBER 04 2018

ENTRANCE VIEW



ENTRANCE VIEW



LIGHTING CONCEPT

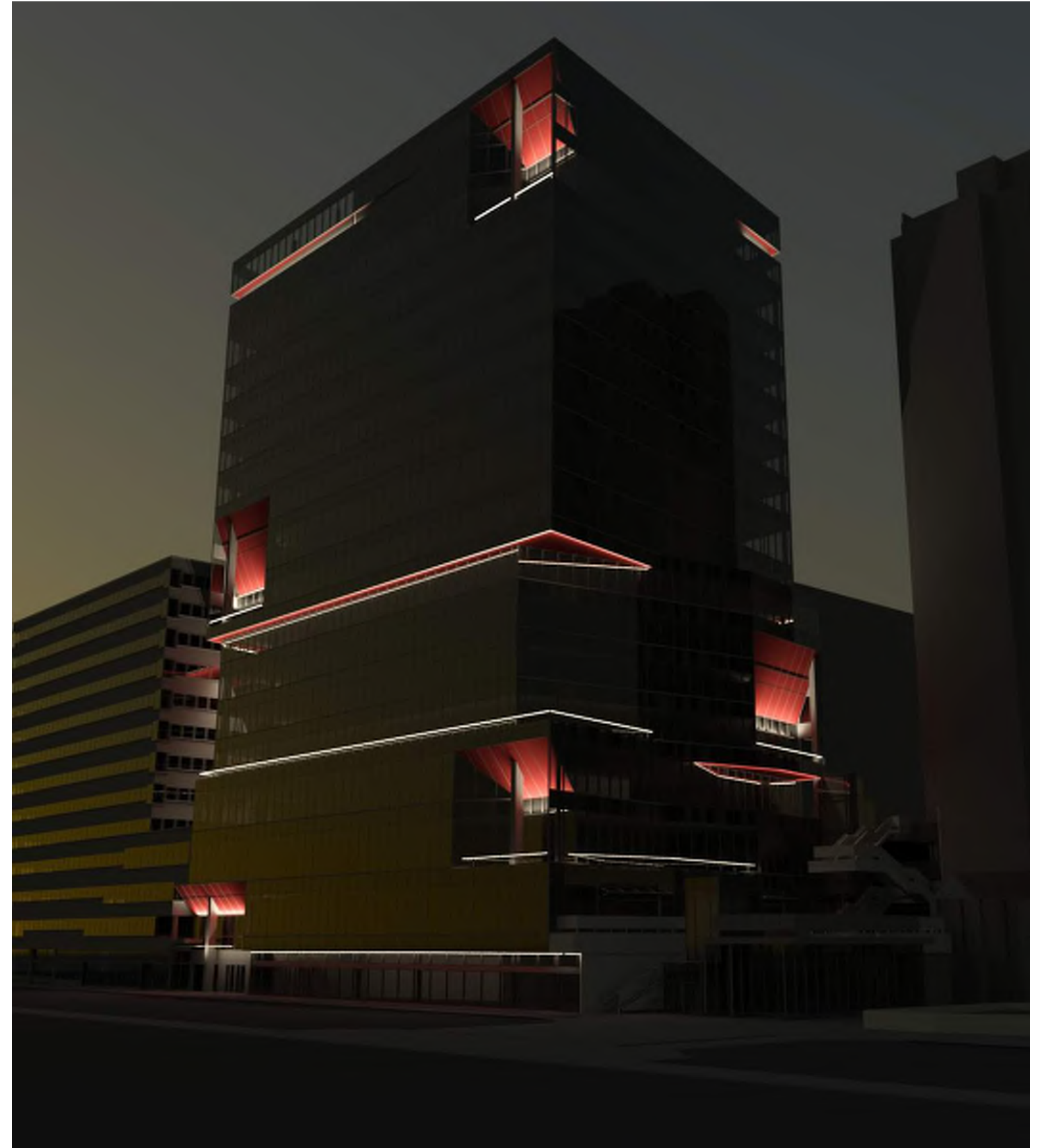
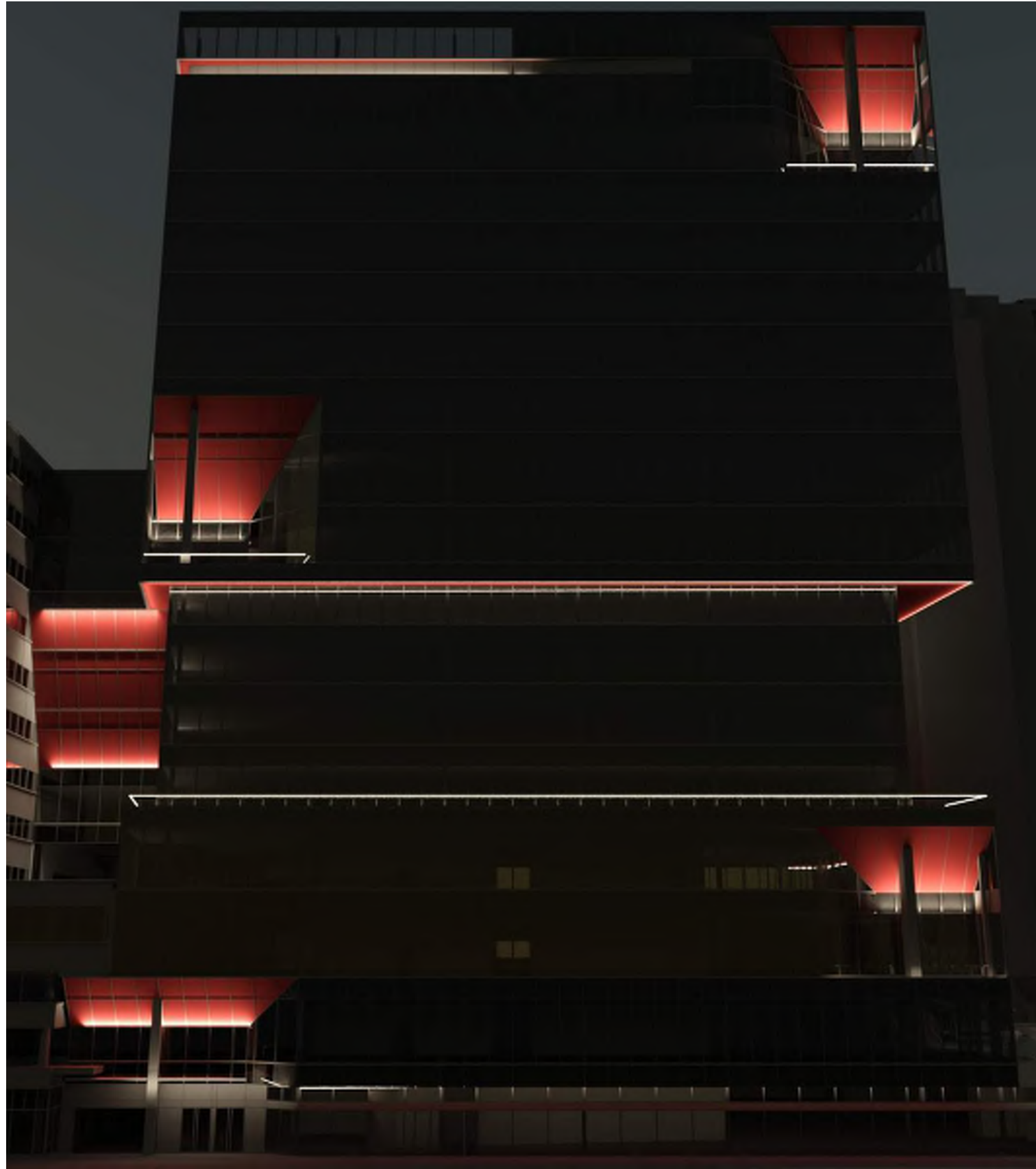

LIGHTING CONCEPT

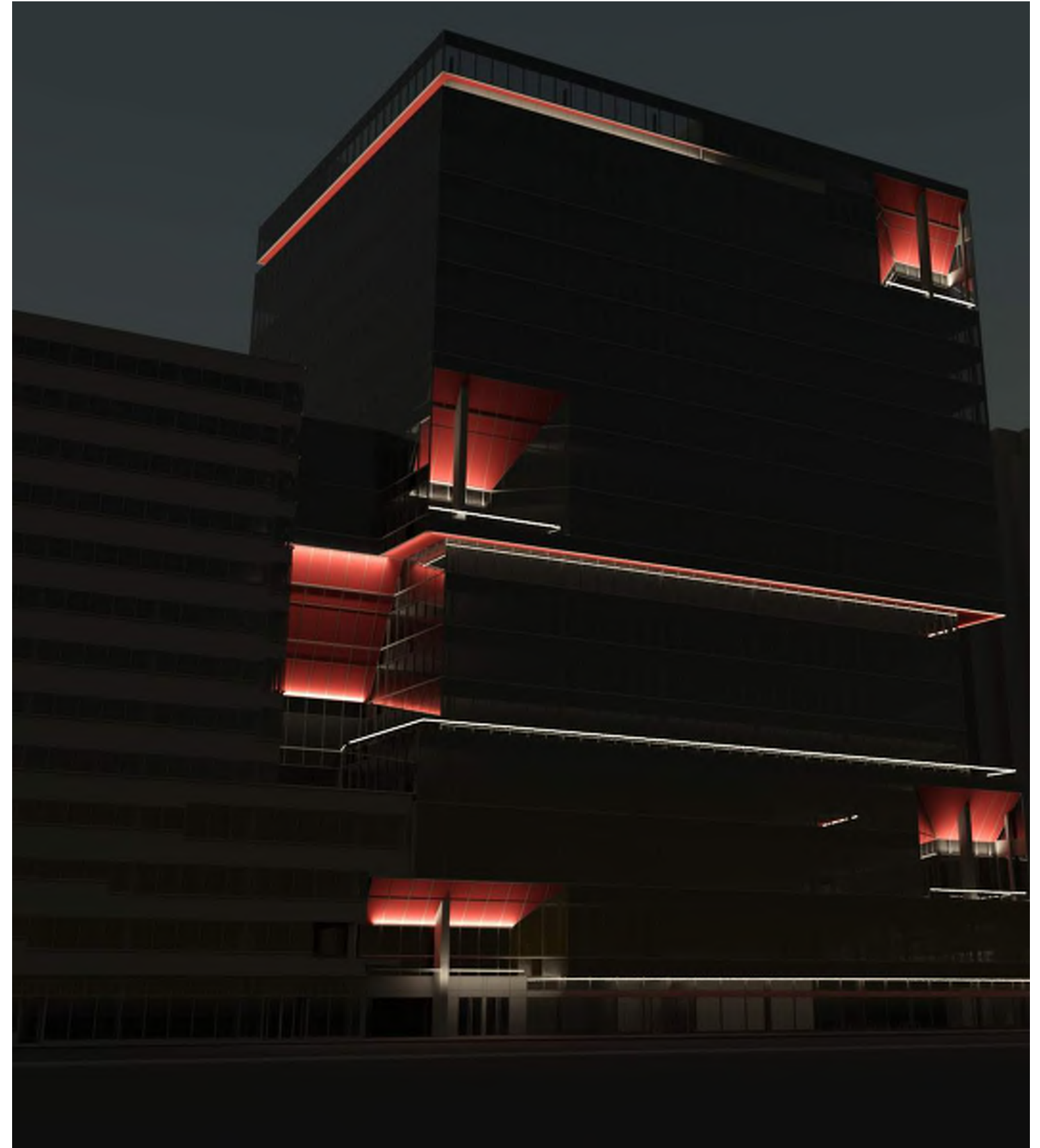
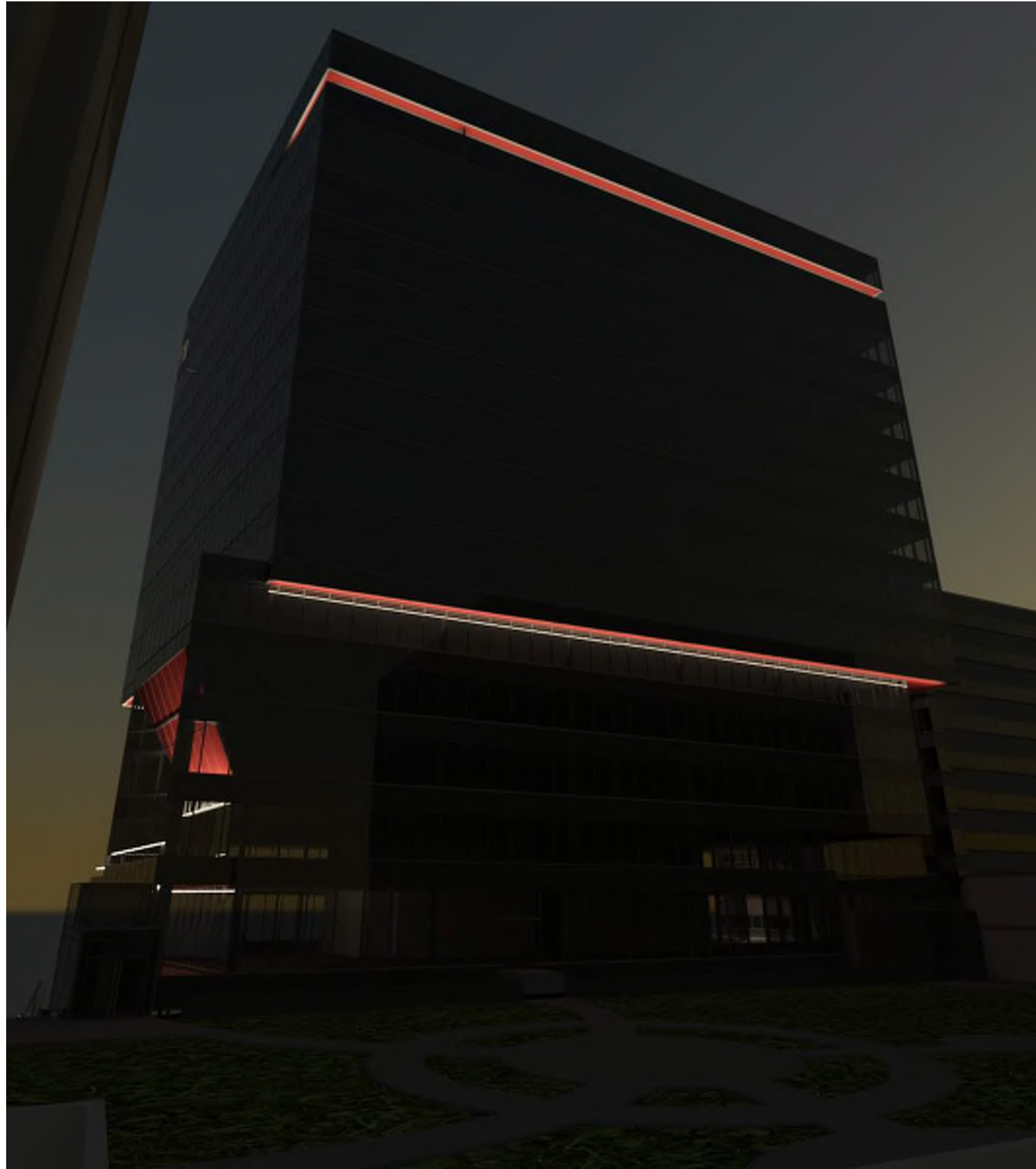

STREET LEVEL PEDESTRIAN EXPERIENCE

LEVEL 1 PLAN

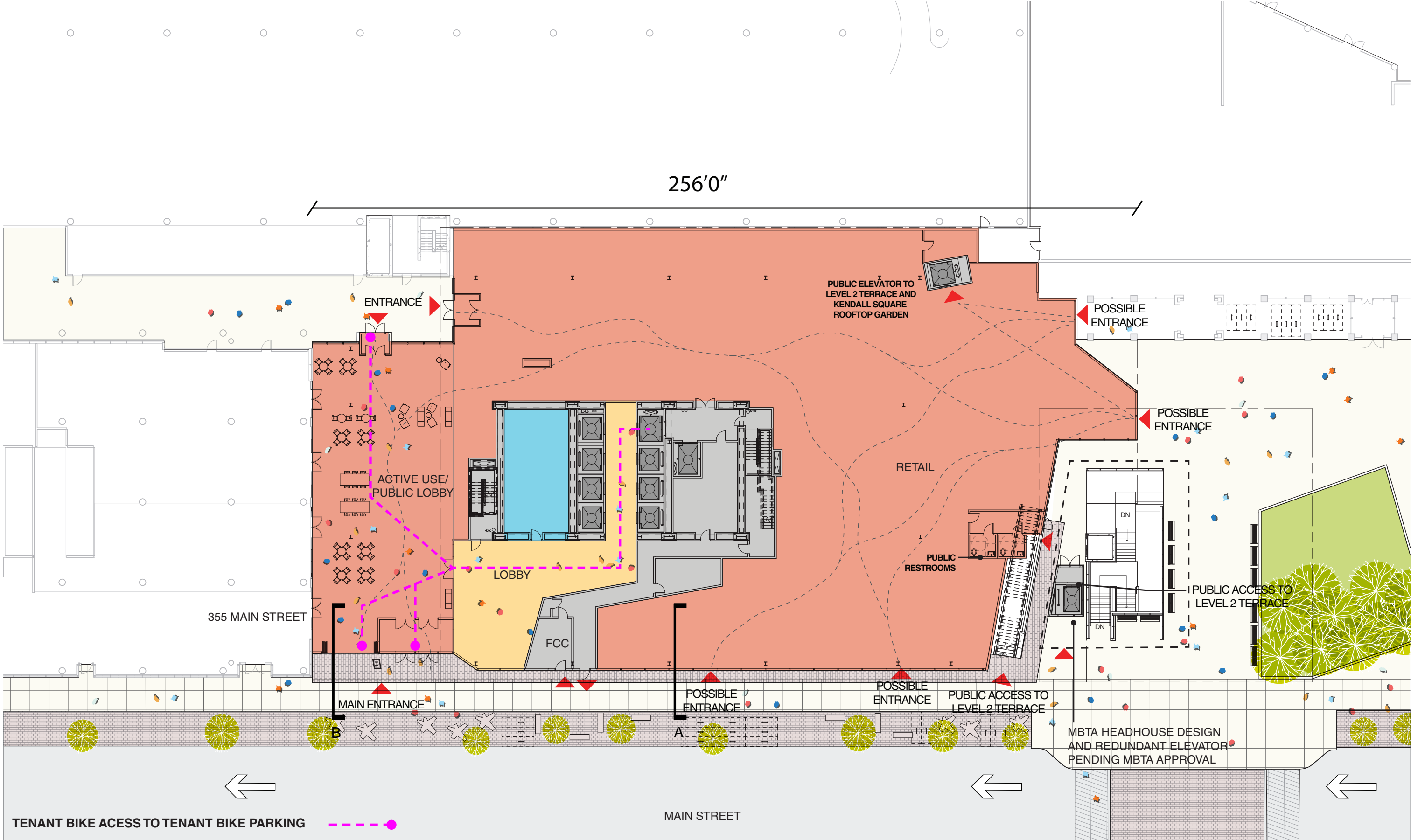

LEVEL 2 PLAN

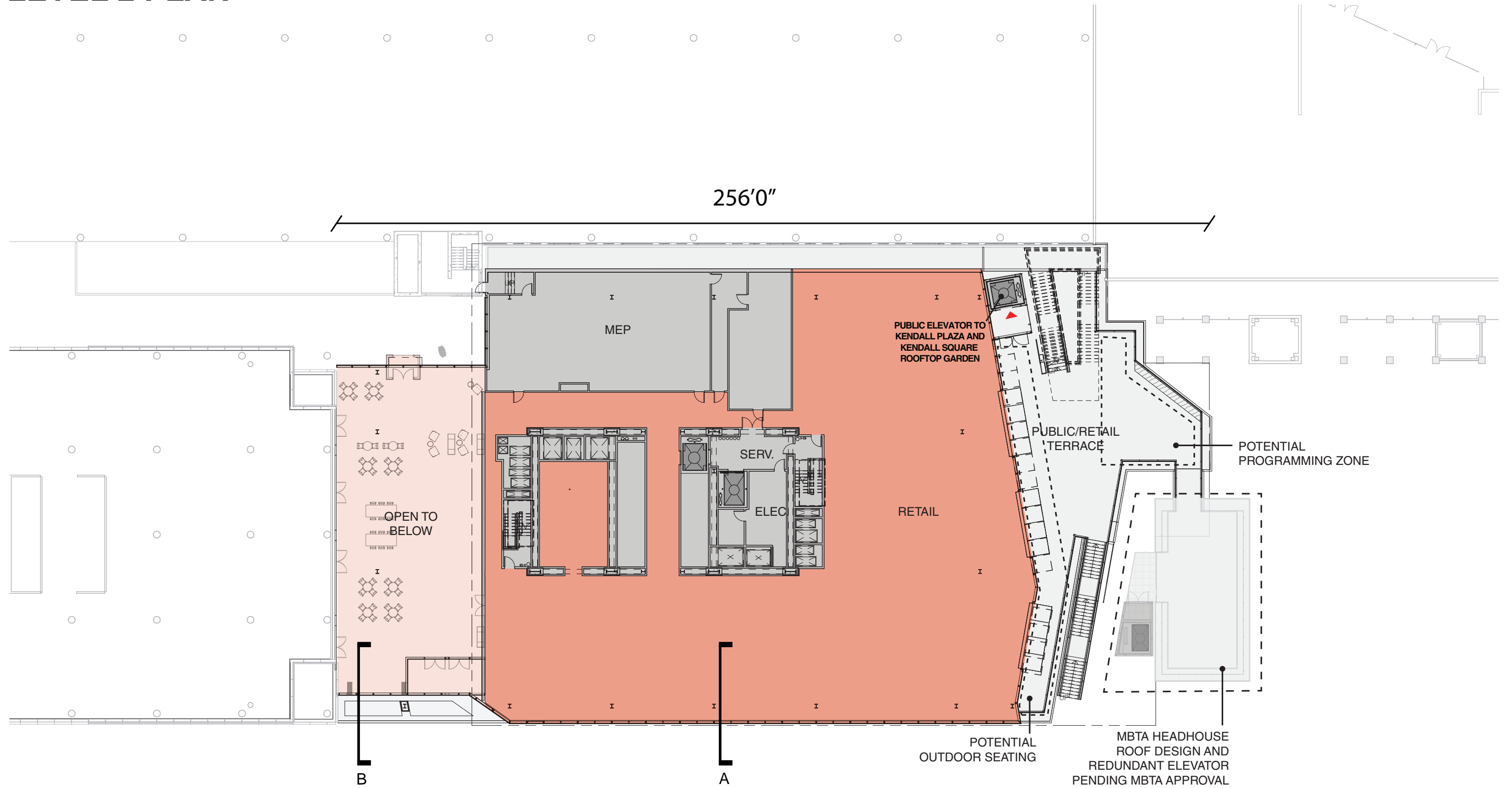

PUBLIC LOBBY - AXONOMETRIC

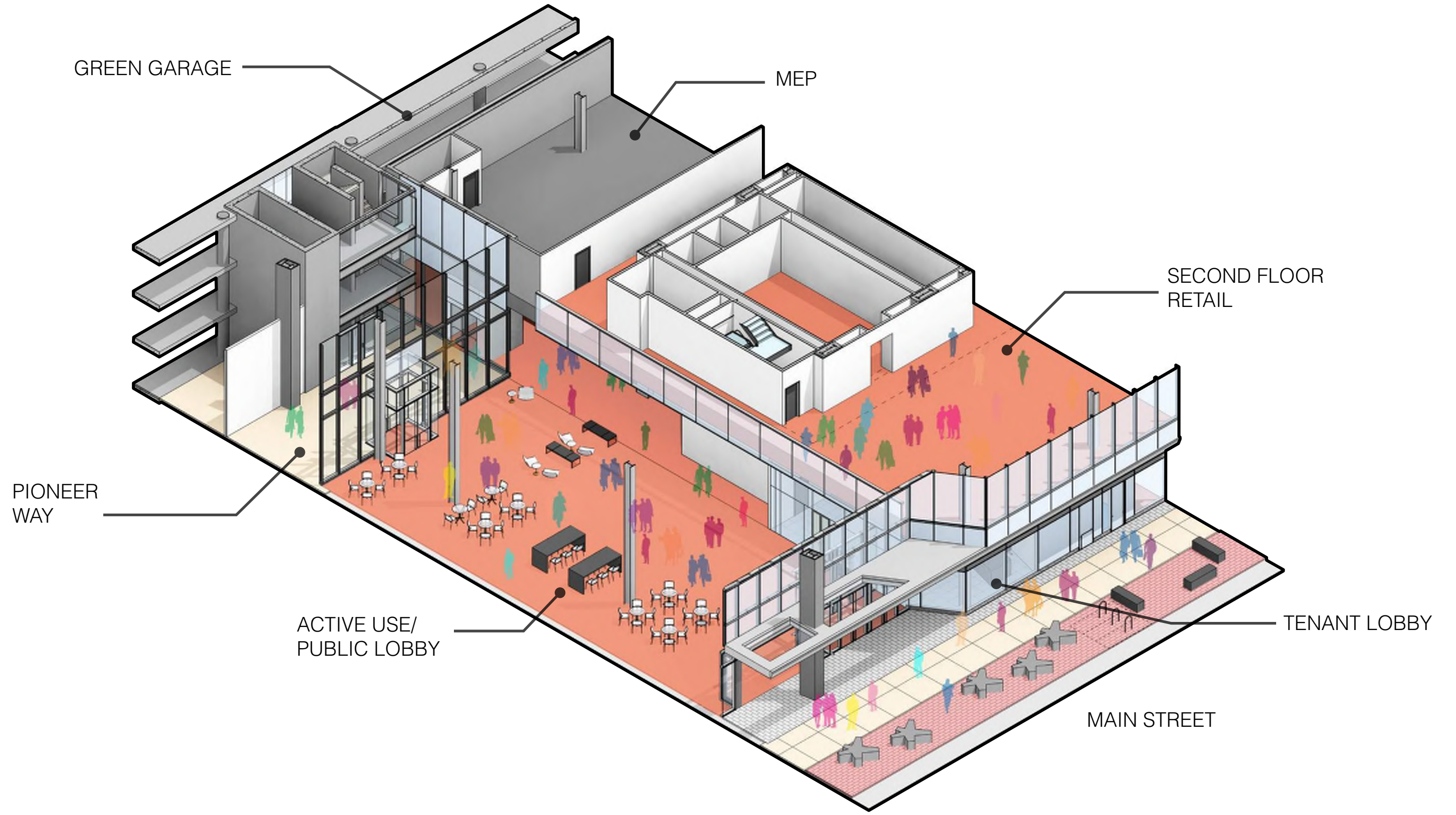

ENLARGED ENTRANCE VIEW



TRANSVERSE SECTIONS

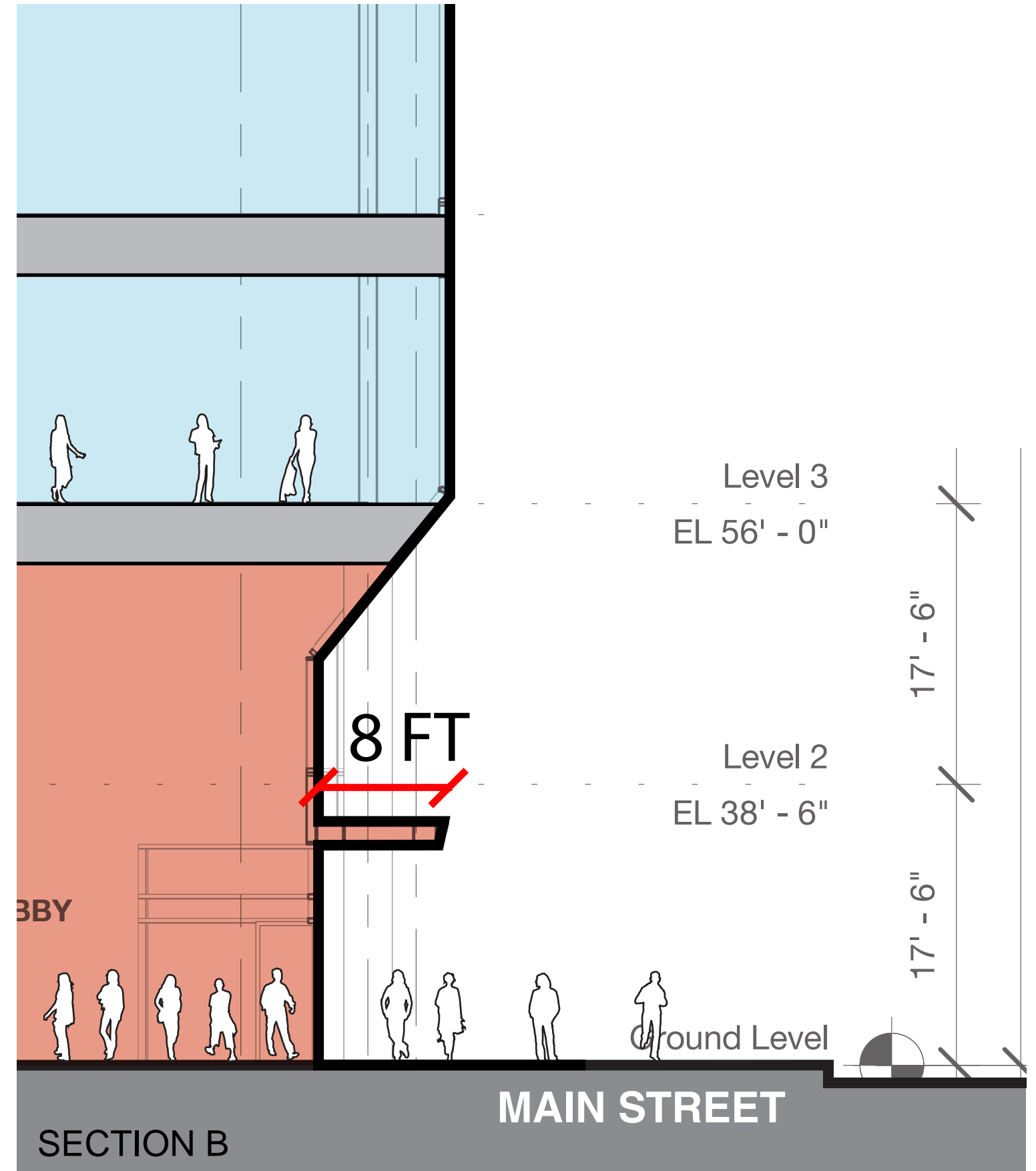
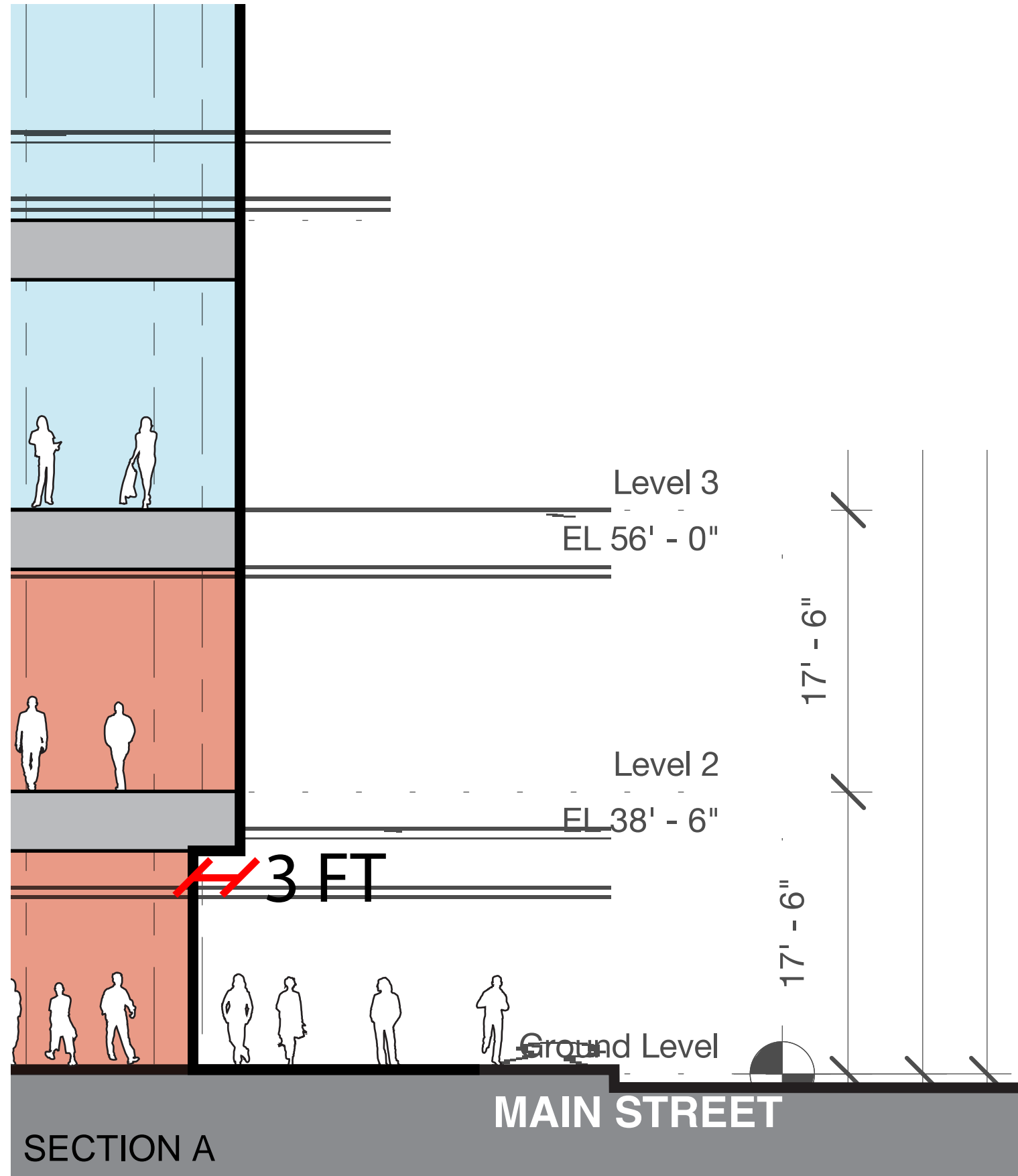

TRANSVERSE SECTIONS

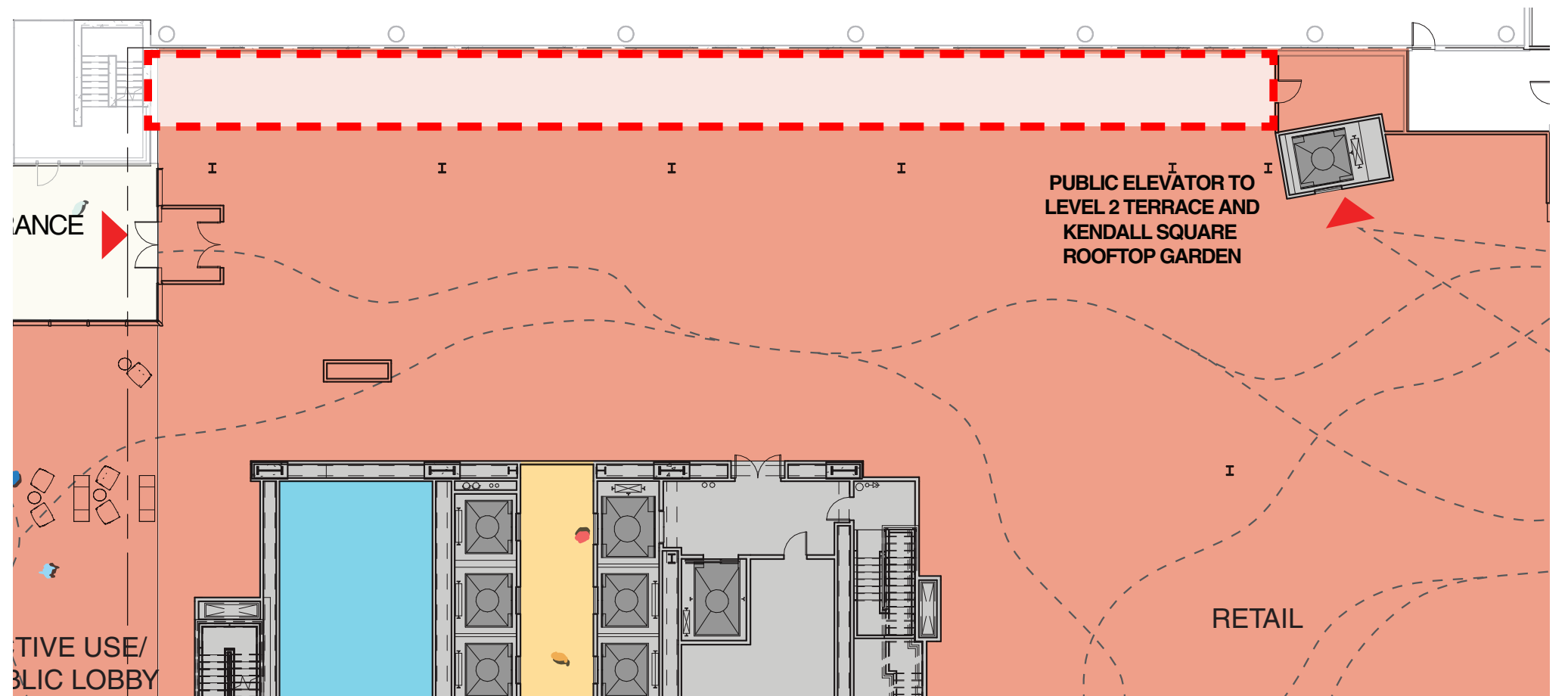
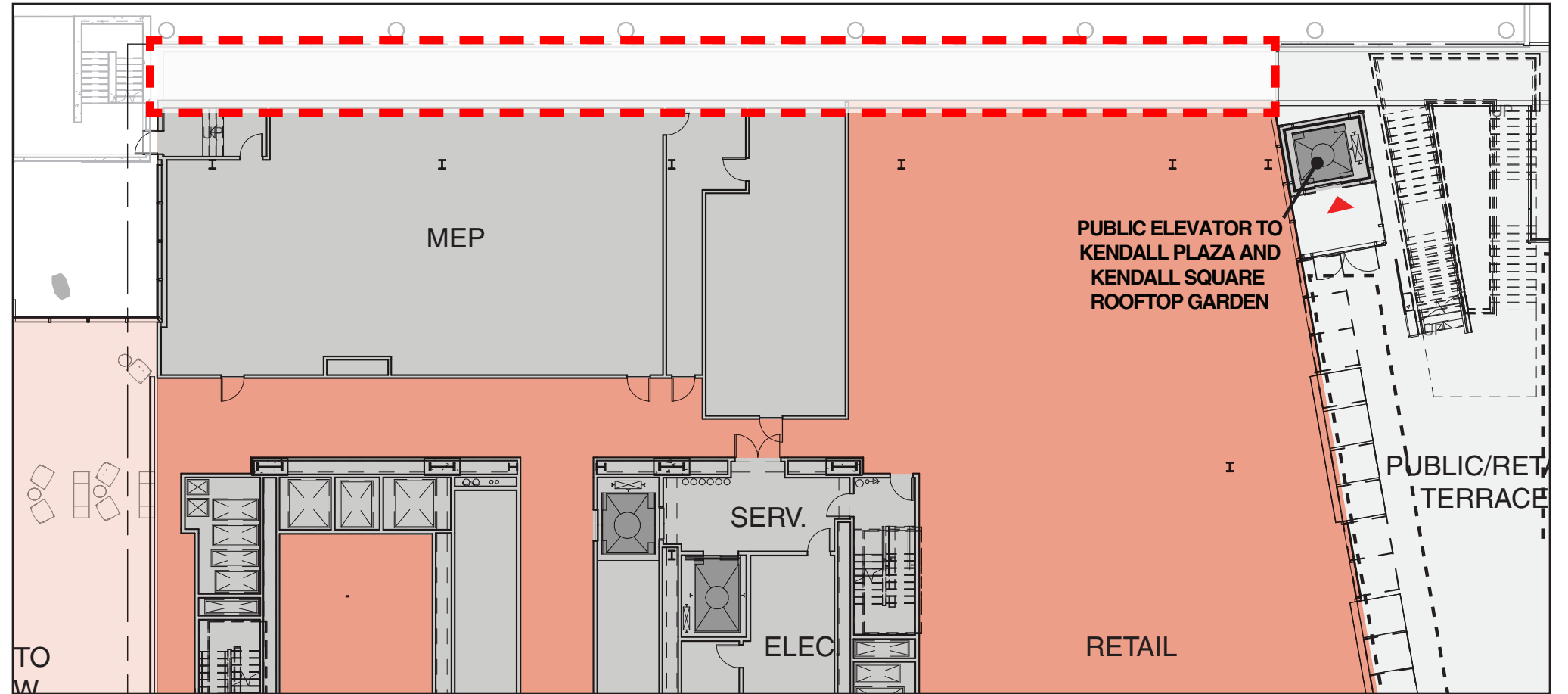
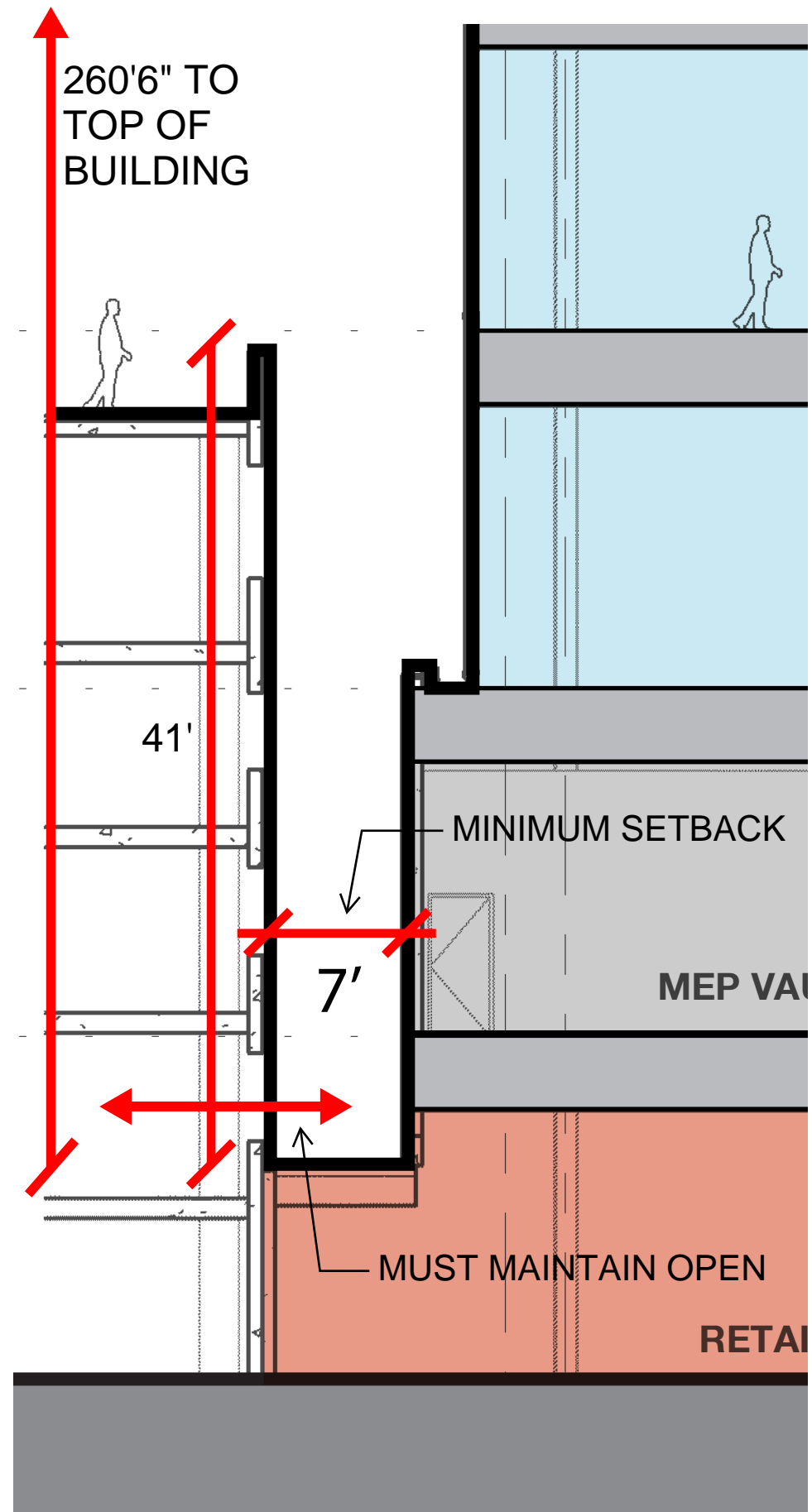

SETBACK/ AWNING

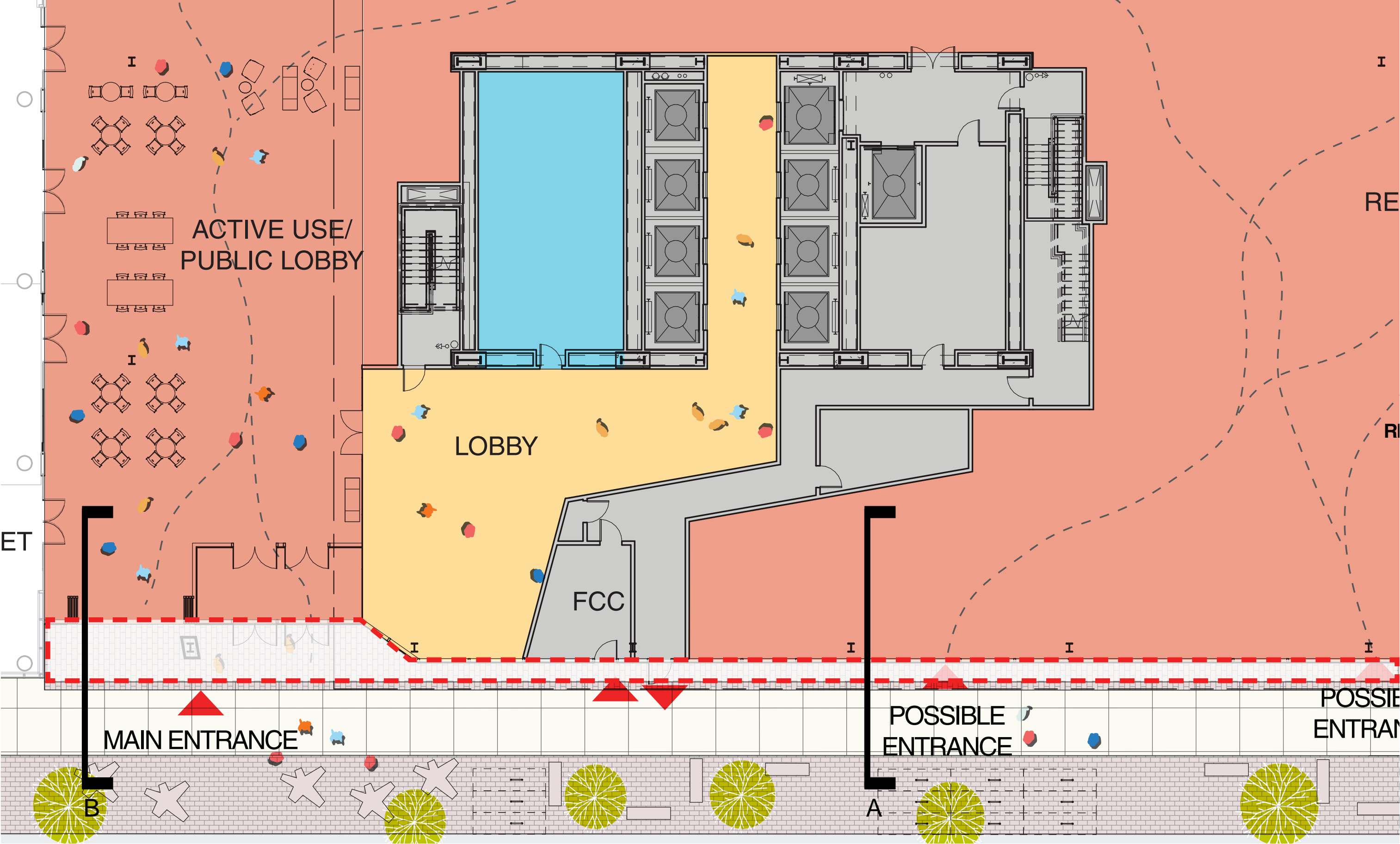

PLAZA/ROOFTOP GARDEN CONNECTION

PLAZA TO ROOFTOP GARDEN CONNECTION DIAGRAM

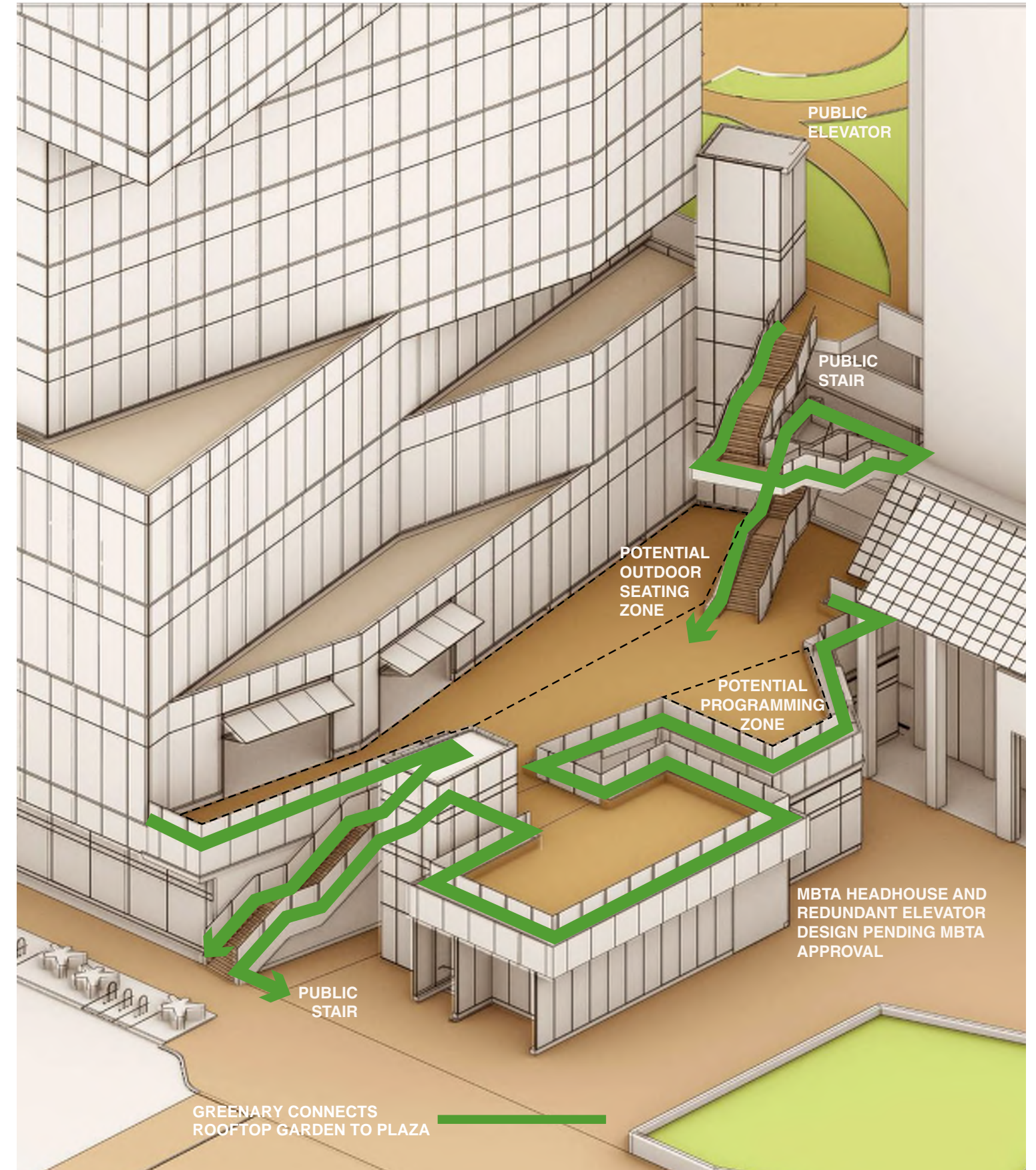
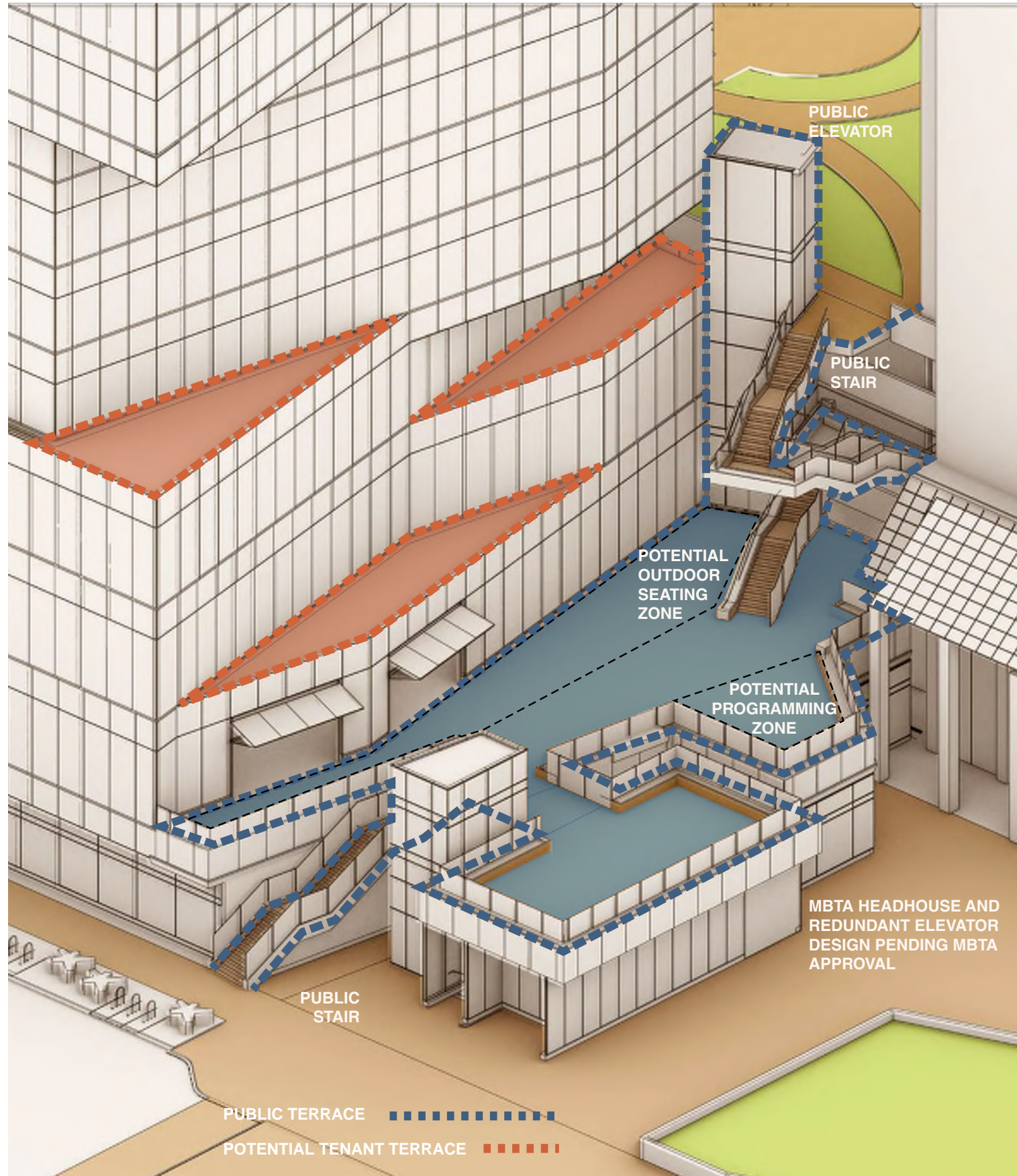

FLOOR PLANS PLAN - INCREASED PLAN DIMENSIONS AROUND HEADHOUSE

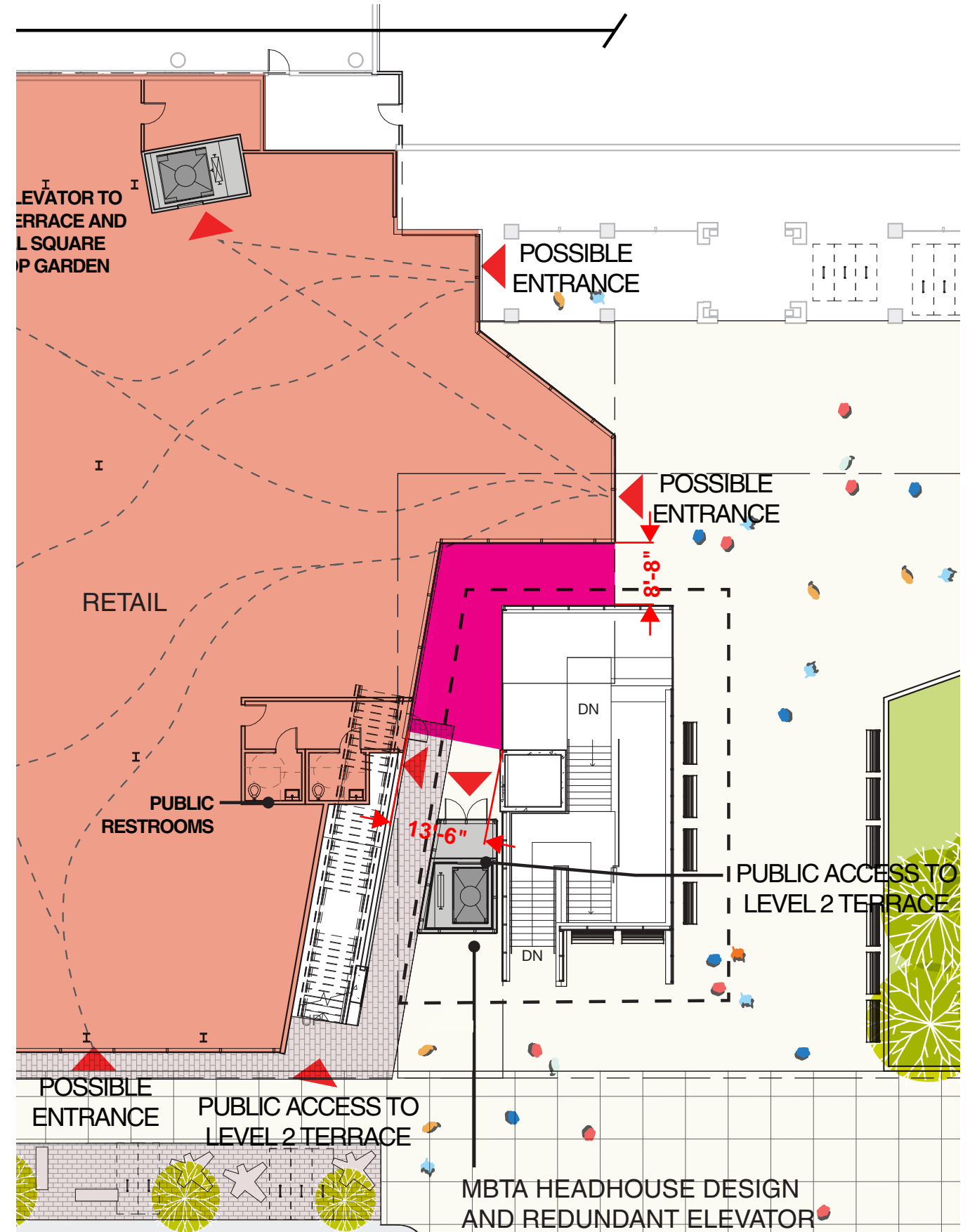
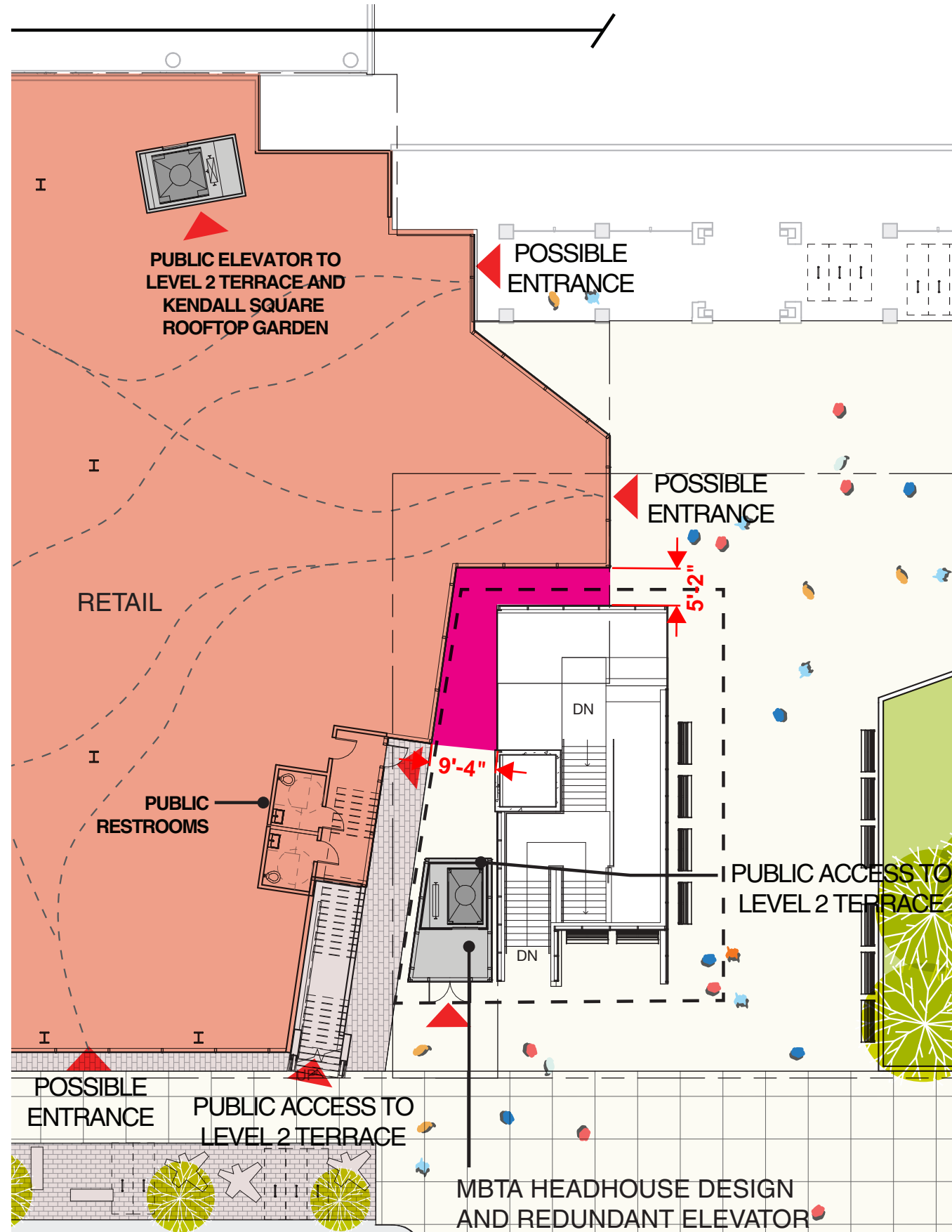

VIEW FROM MAIN STREET CROSSWALK



VIEW FROM MAIN STREET CROSSWALK



**THIS AREA PENDING
MBTA APPROVAL**

VIEW FROM ROOFTOP GARDEN TO PLAZA

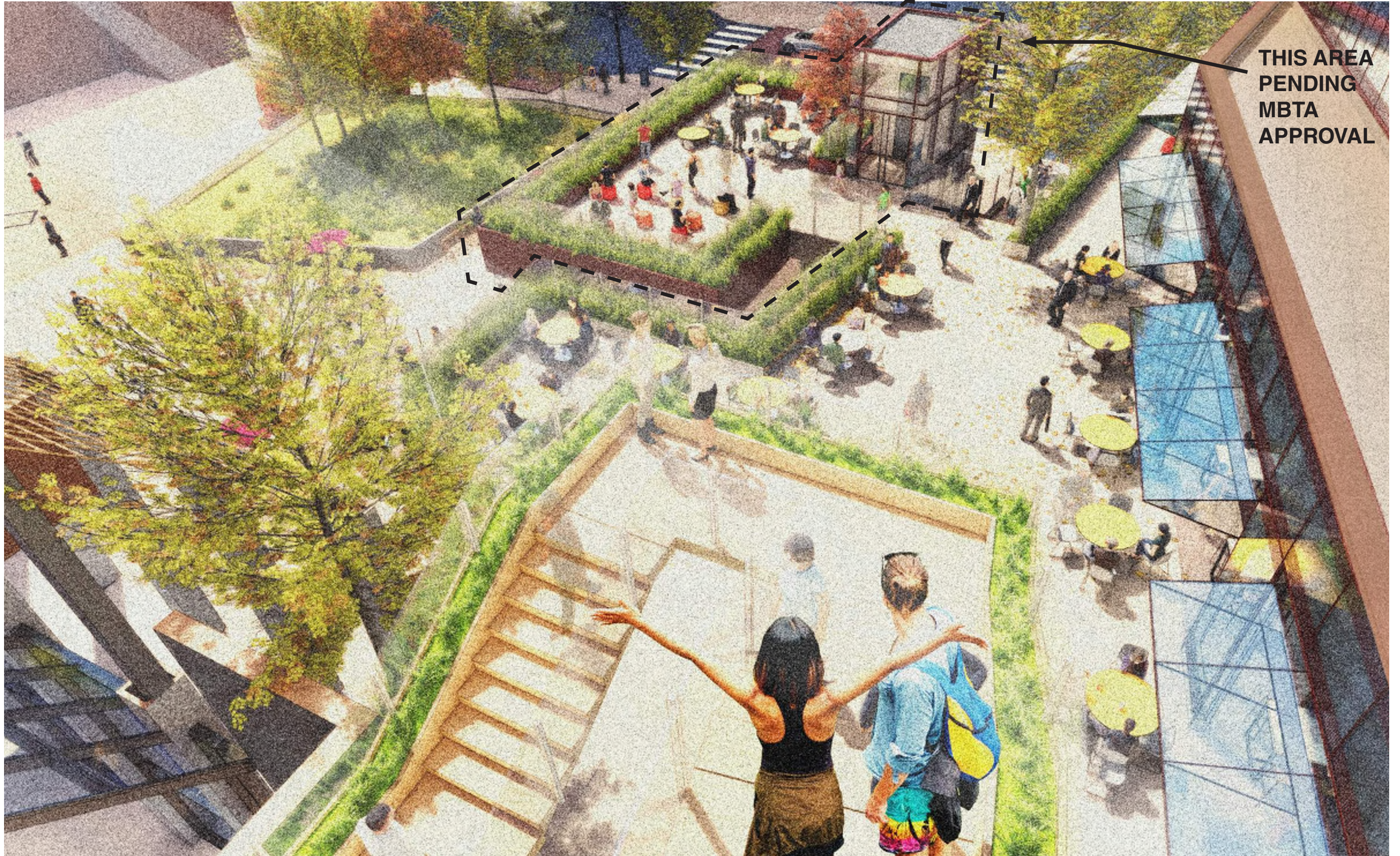

THIS AREA
PENDING
MBTA
APPROVAL

LEVEL 2 - ROOFTOP STAIR STUDIES - BASE CASE

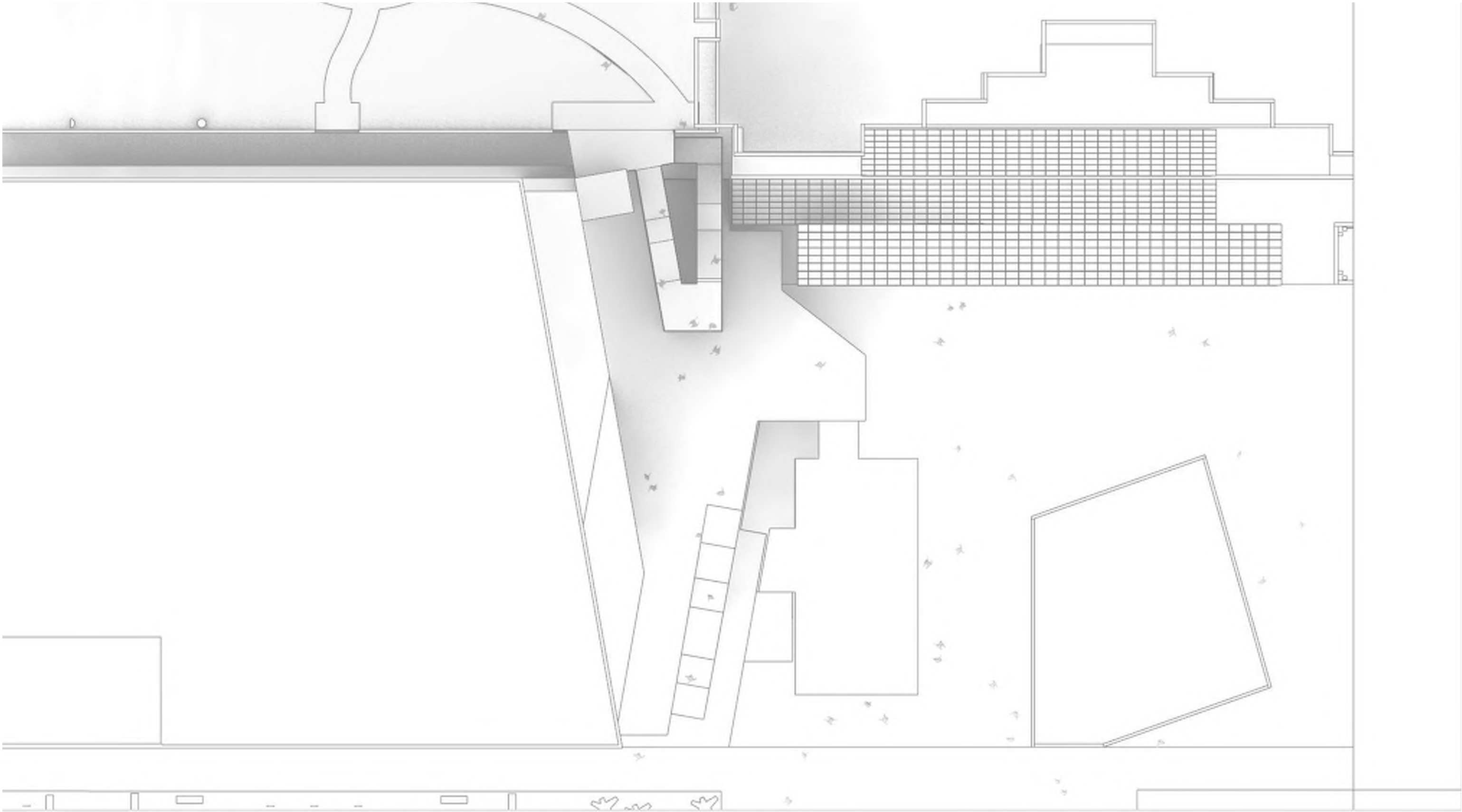

PLAZA TO LEVEL 2 STAIR STUDIES

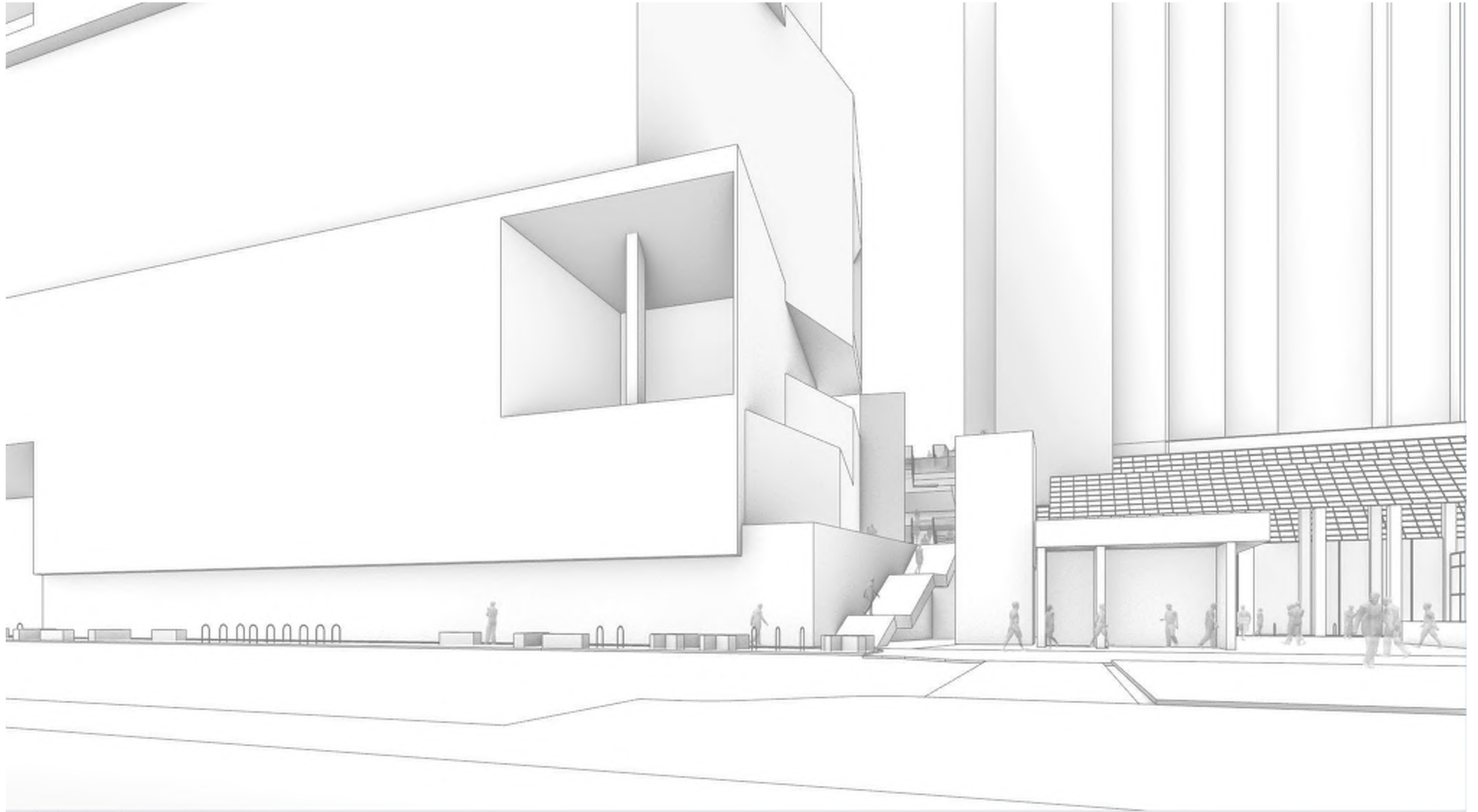

LEVEL 2 - ROOFTOP STAIR STUDIES - ALT 1

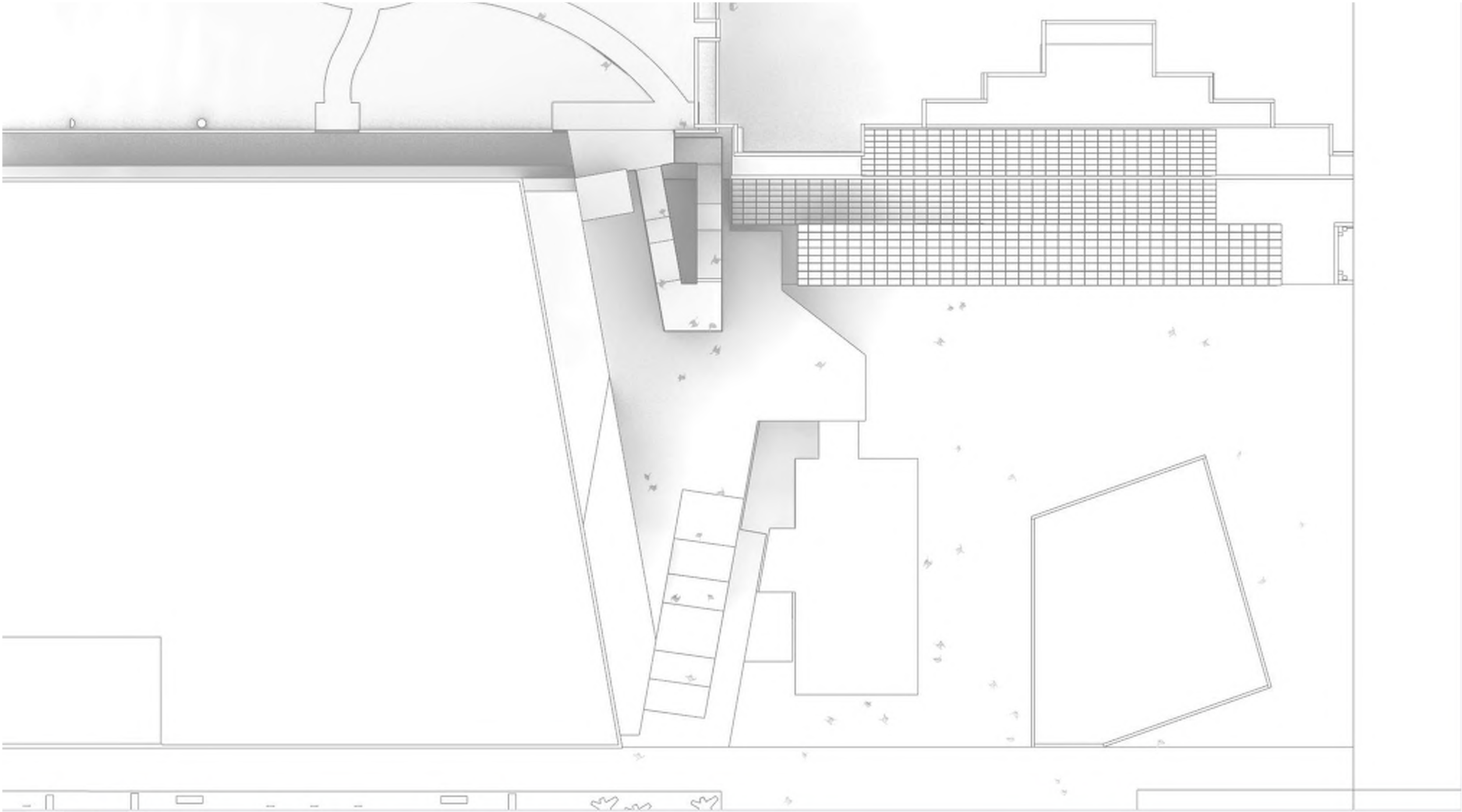

PLAZA TO LEVEL 2 STAIR STUDIES

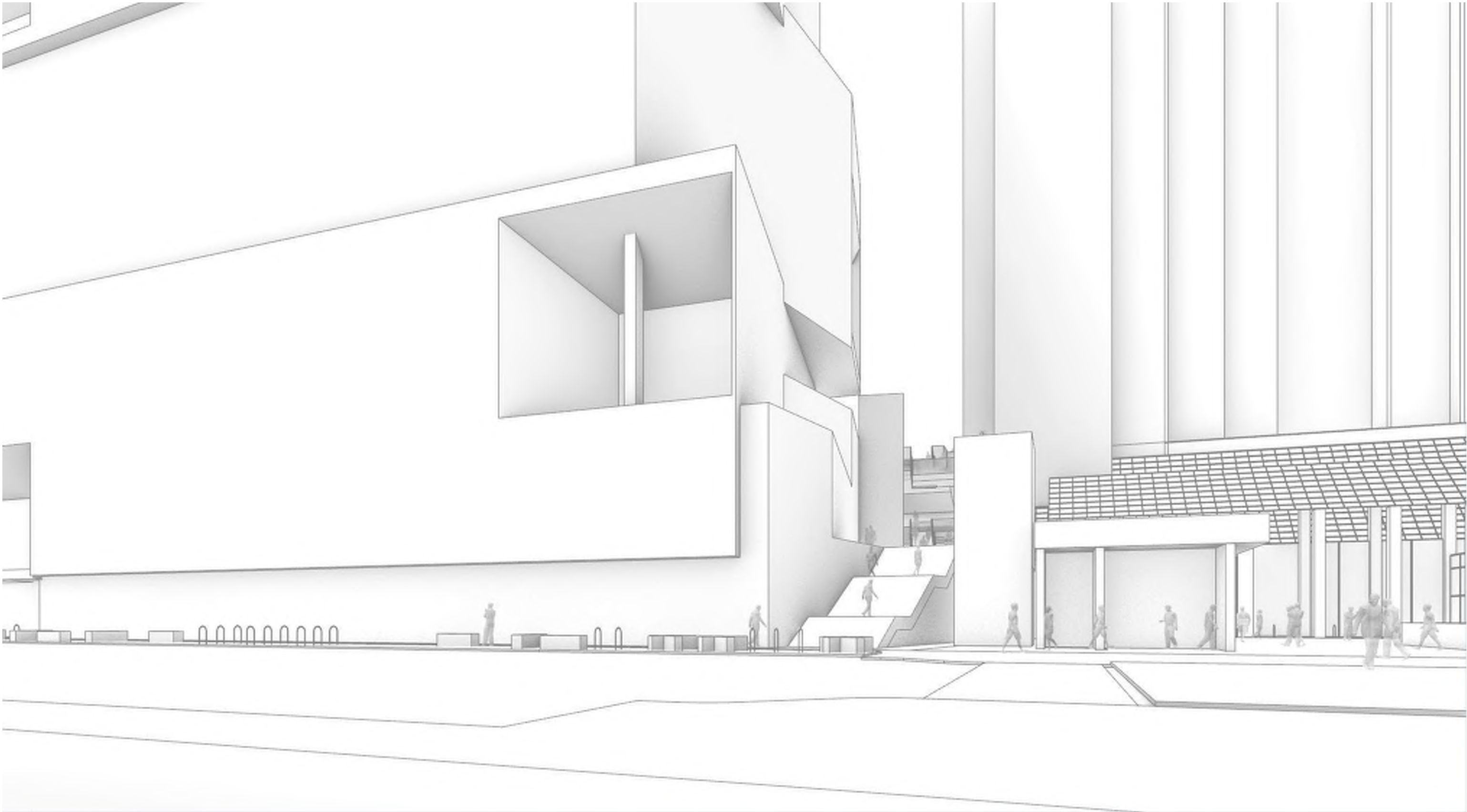

VIEW FROM ROOFTOP GARDEN TO PLAZA

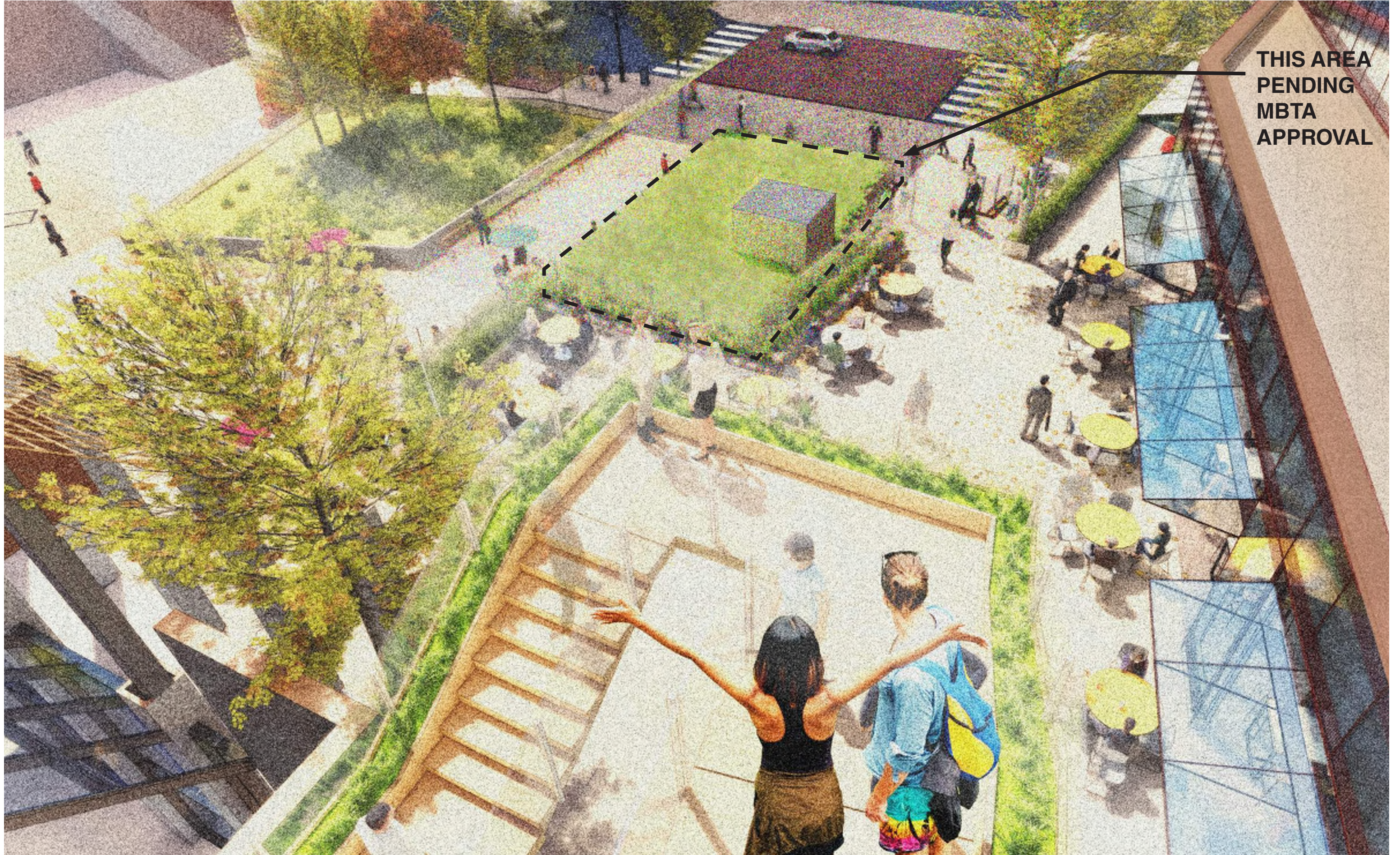

THIS AREA
PENDING
MBTA
APPROVAL

LEVEL 2 - ROOFTOP STAIR STUDIES - BASE CASE

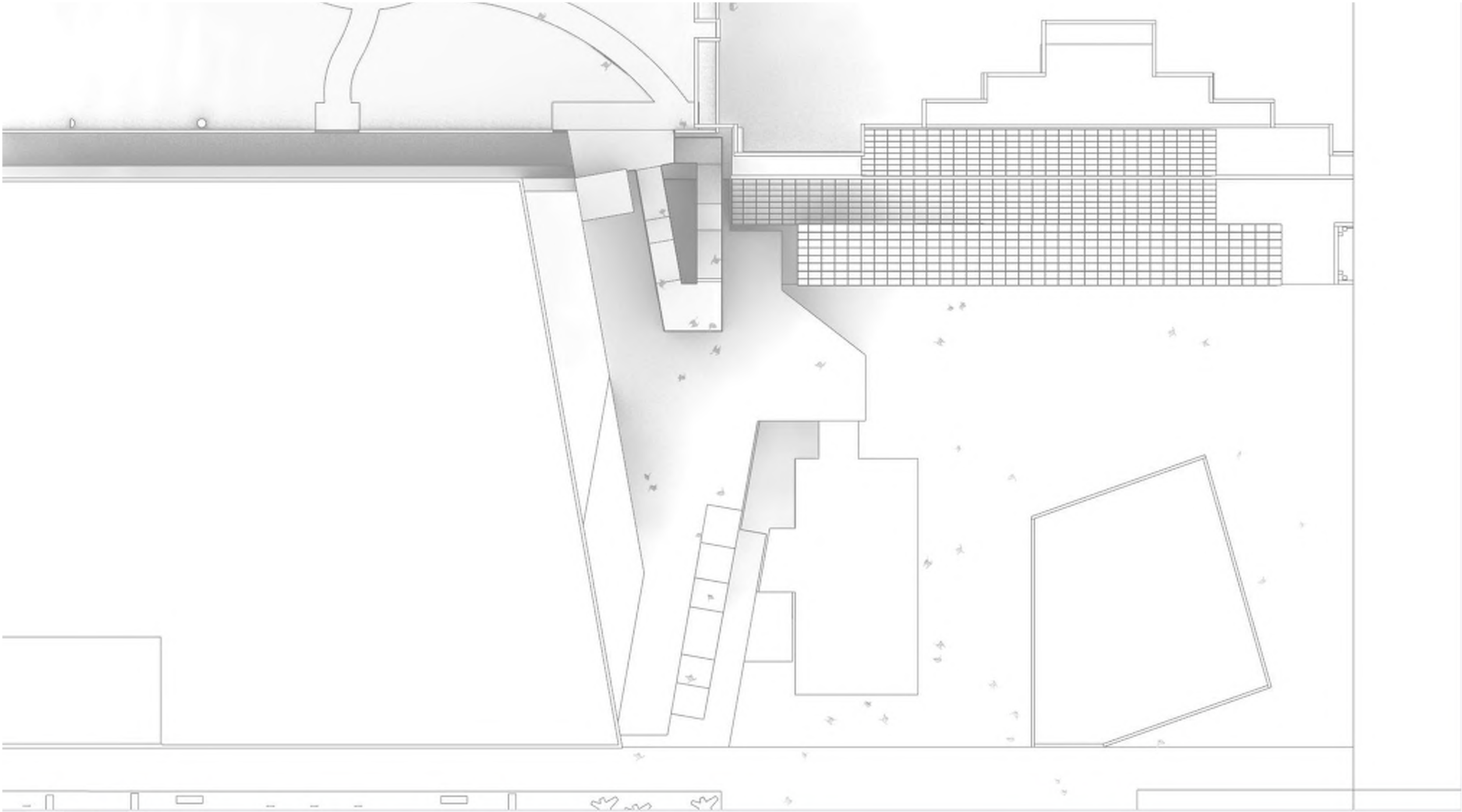

LEVEL 2 - ROOFTOP STAIR STUDIES - ALT 1

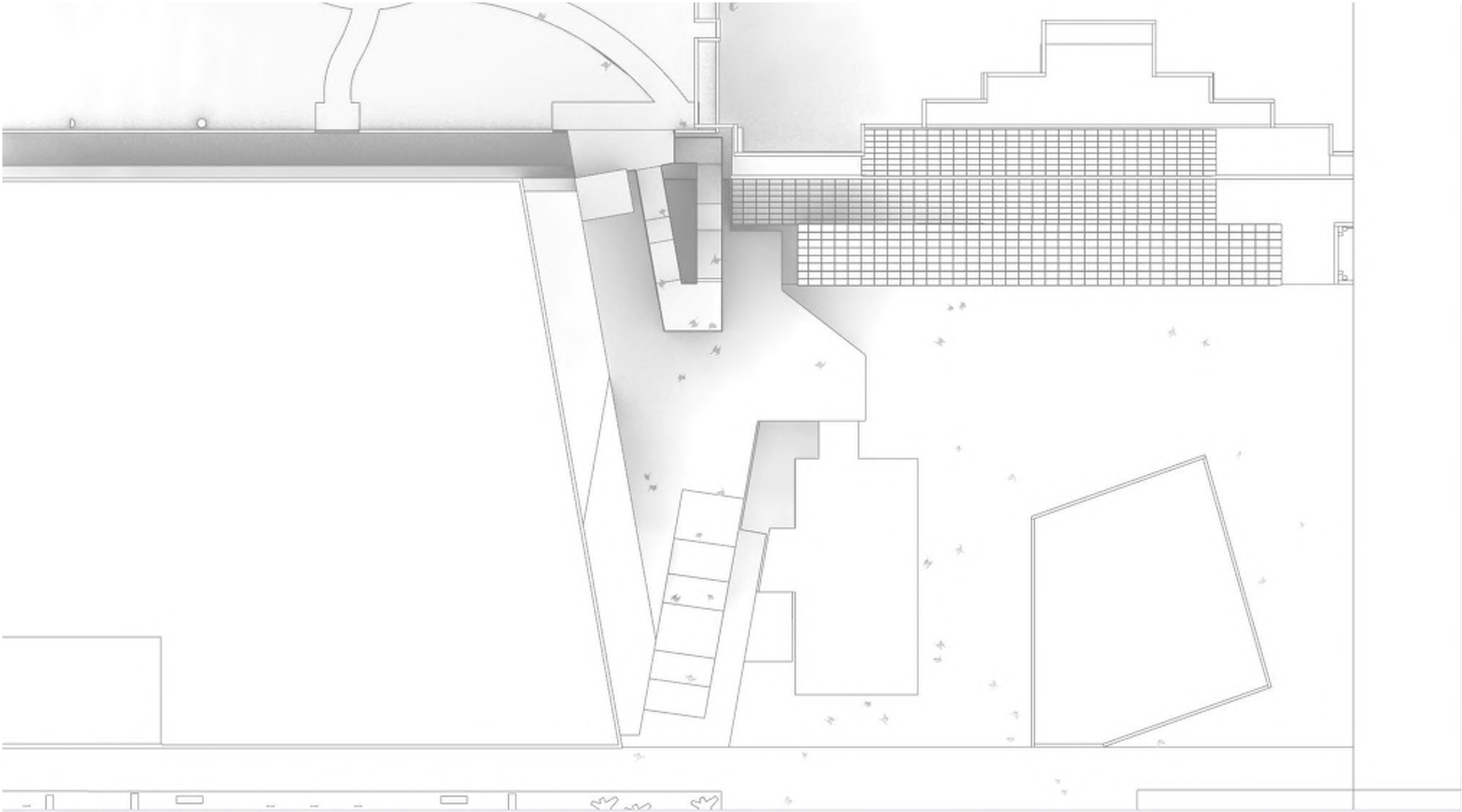

LEVEL 2 - ROOFTOP STAIR STUDIES - ALT 3

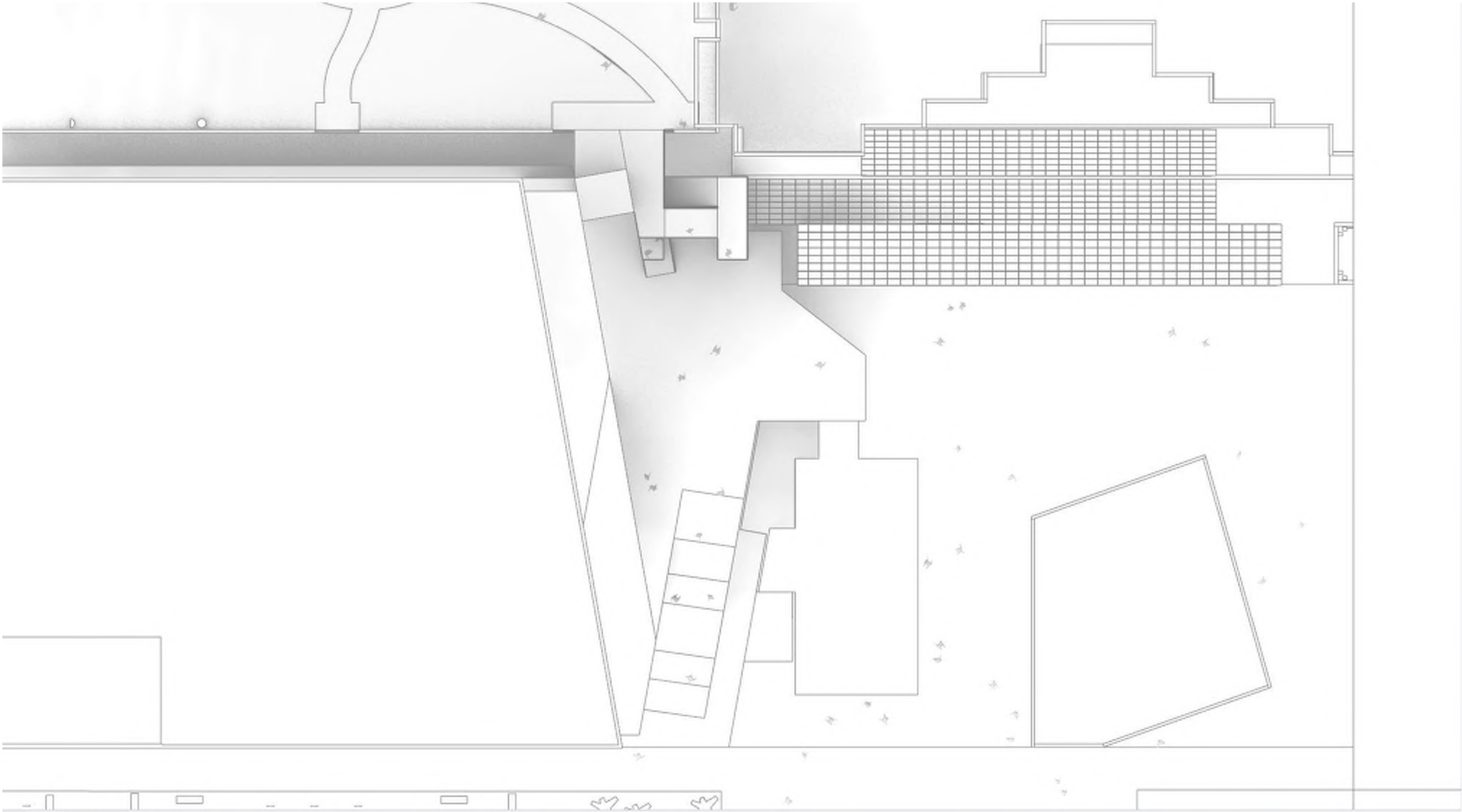

LEVEL 2 - ROOFTOP STAIR STUDIES - ALT 4

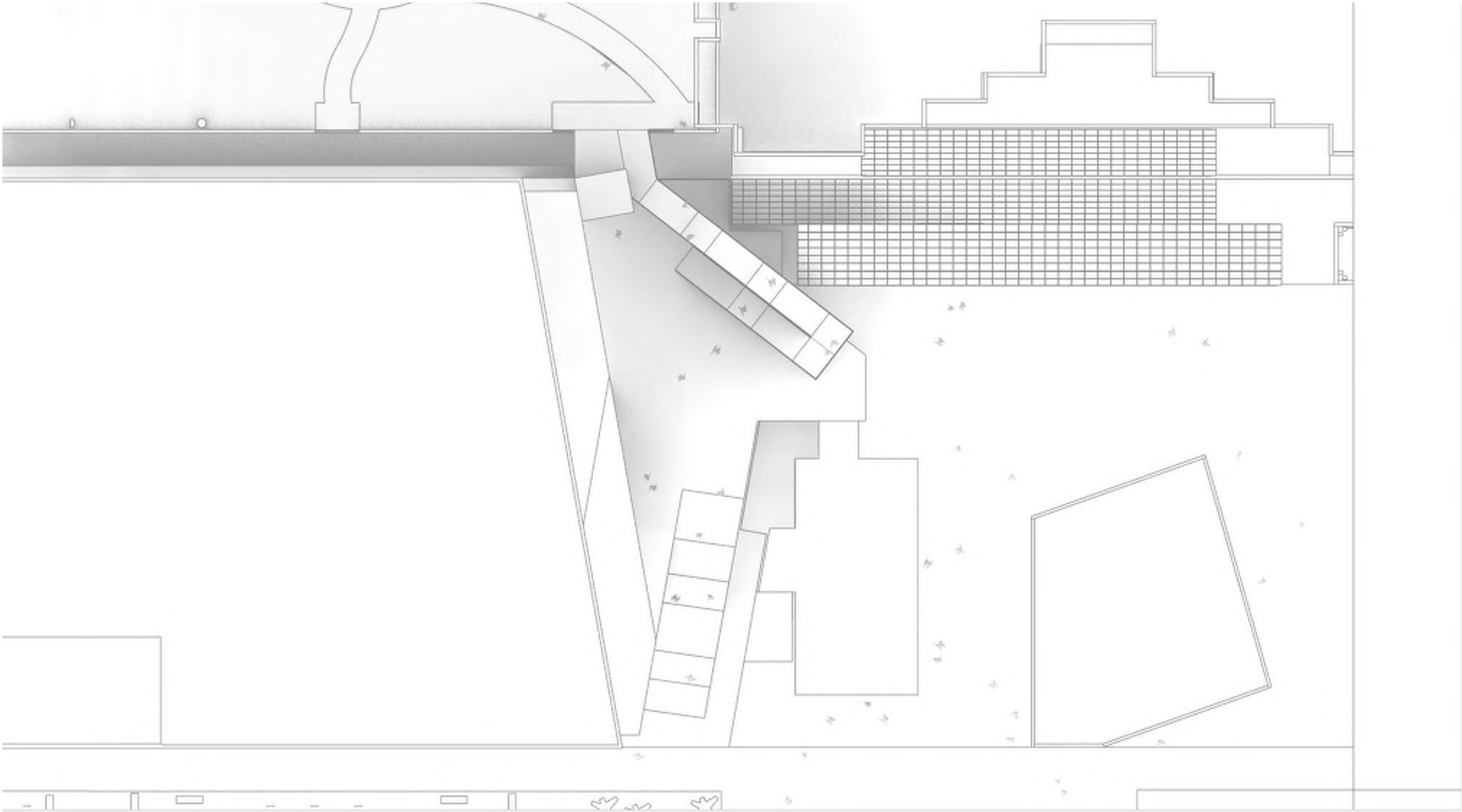

LEVEL 2 - ROOFTOP STAIR STUDIES - ALT 1

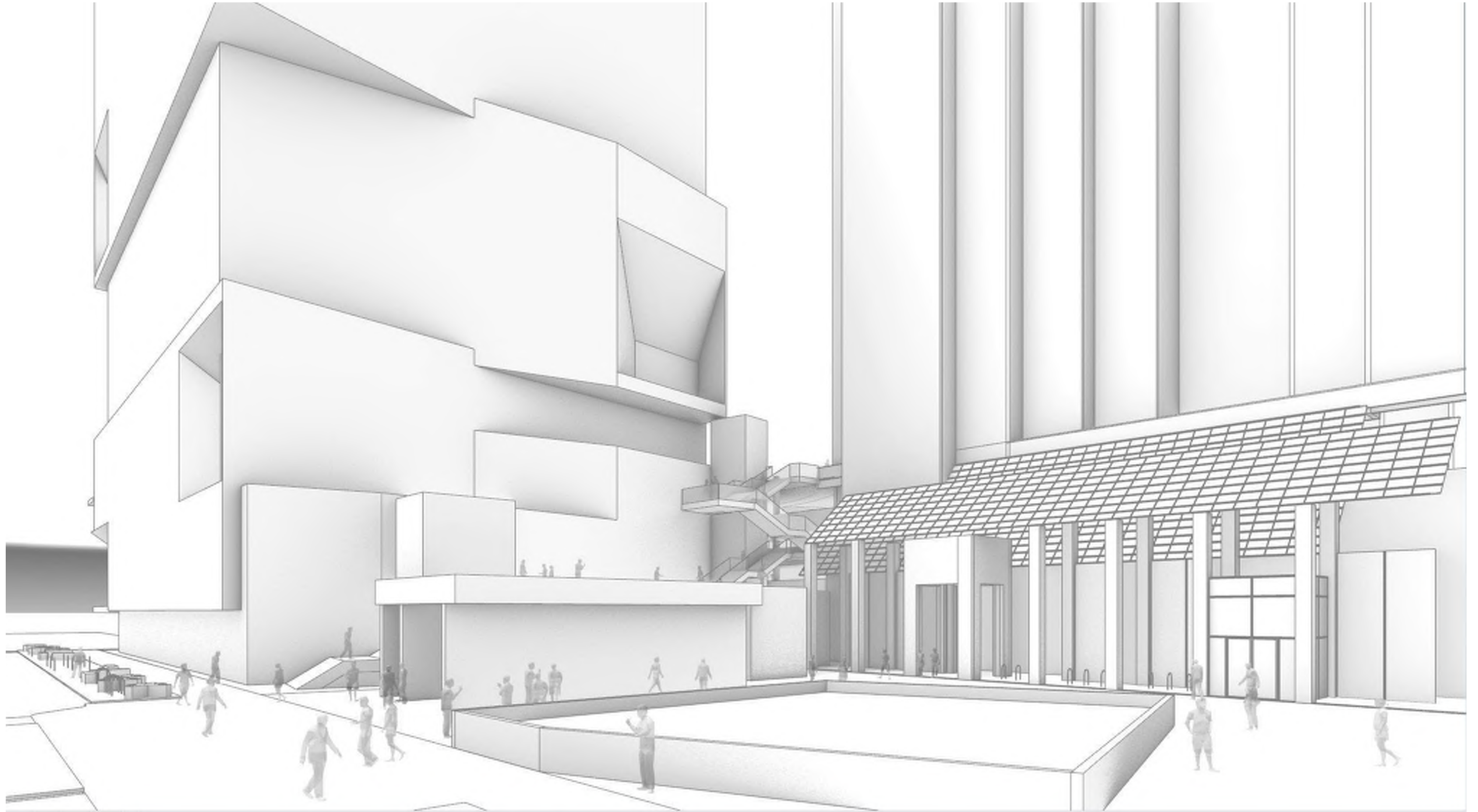

LEVEL 2 - ROOFTOP STAIR STUDIES - ALT 3

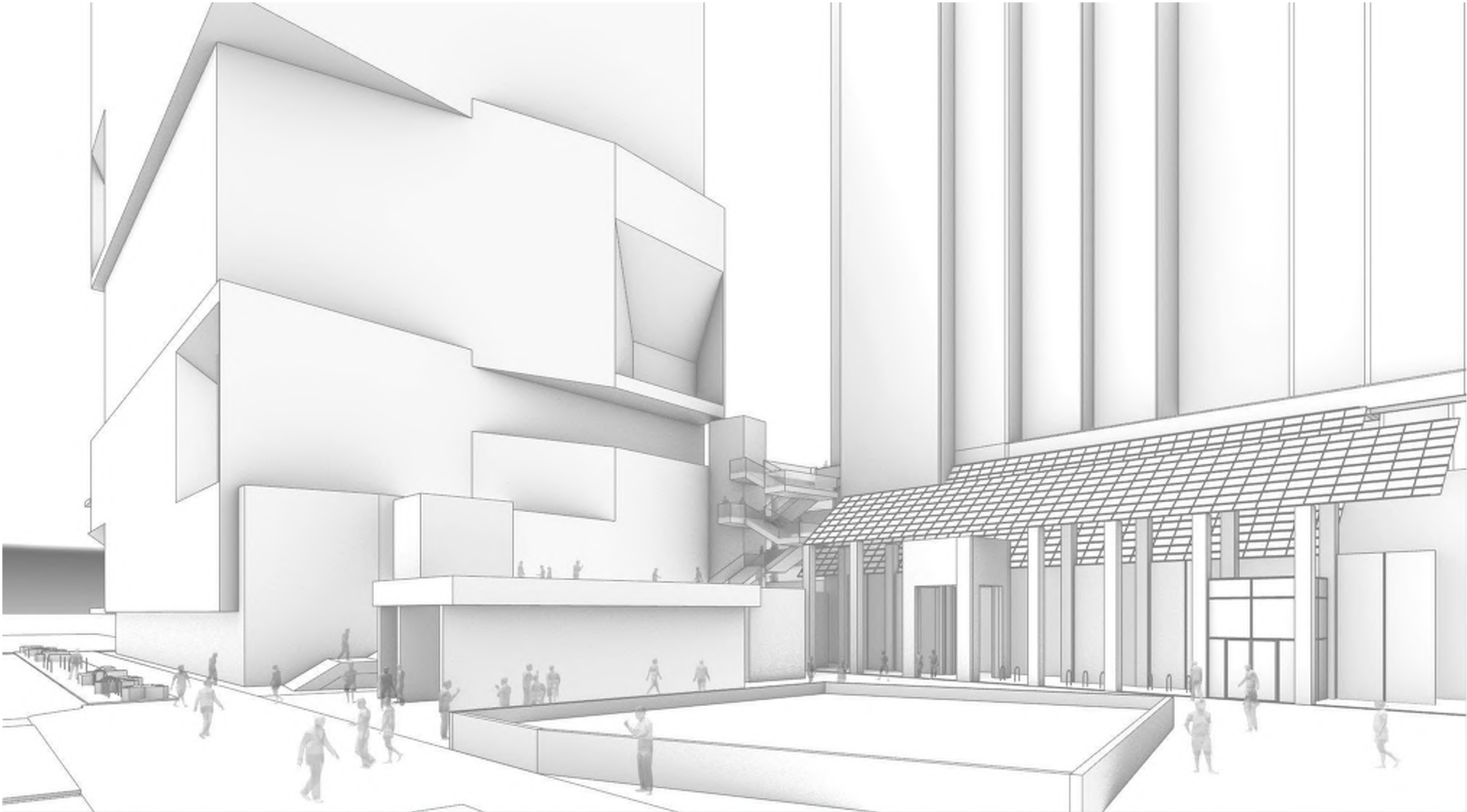

LEVEL 2 - ROOFTOP STAIR STUDIES - ALT 4

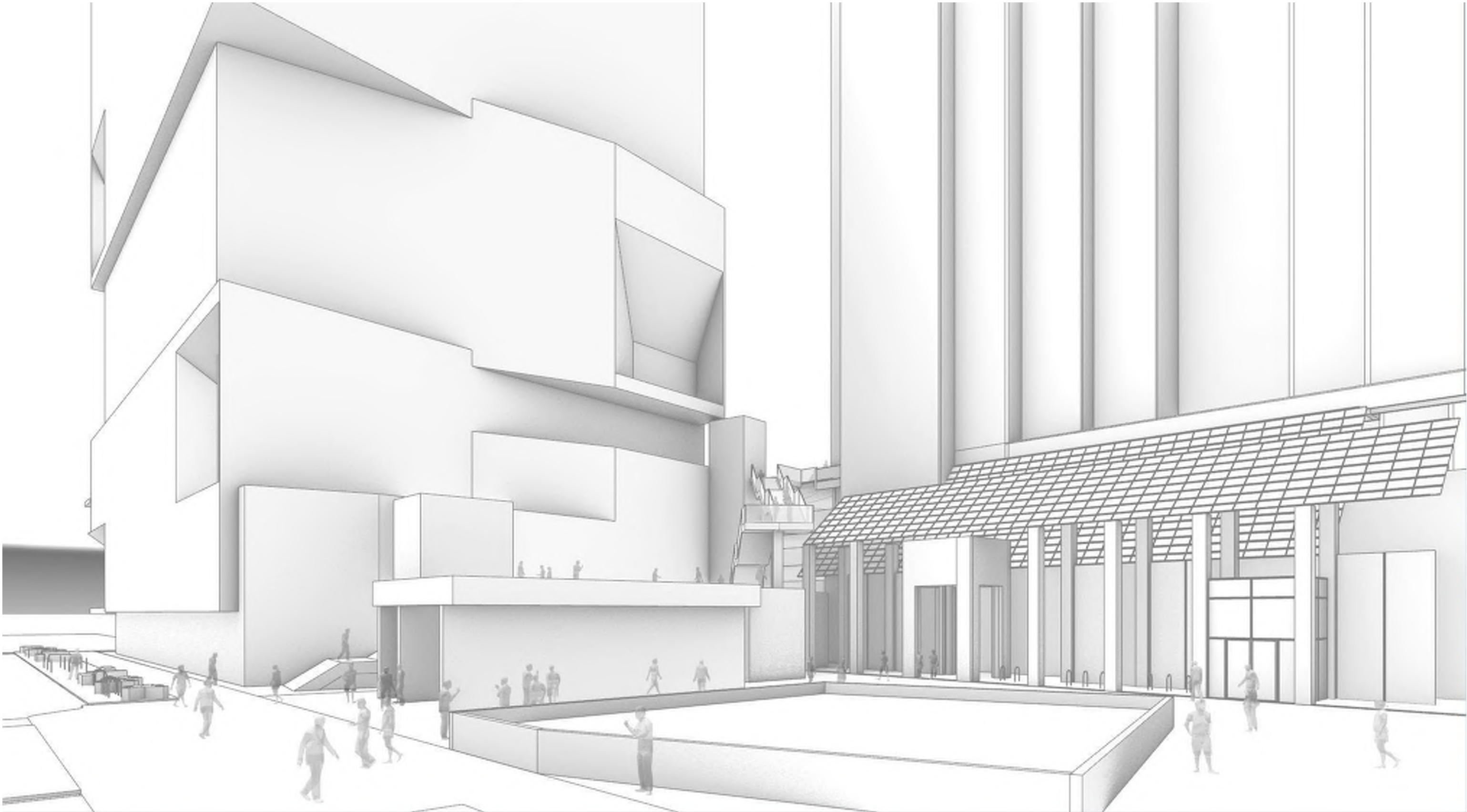

LEVEL 2 - ROOFTOP STAIR STUDIES - ALT 1

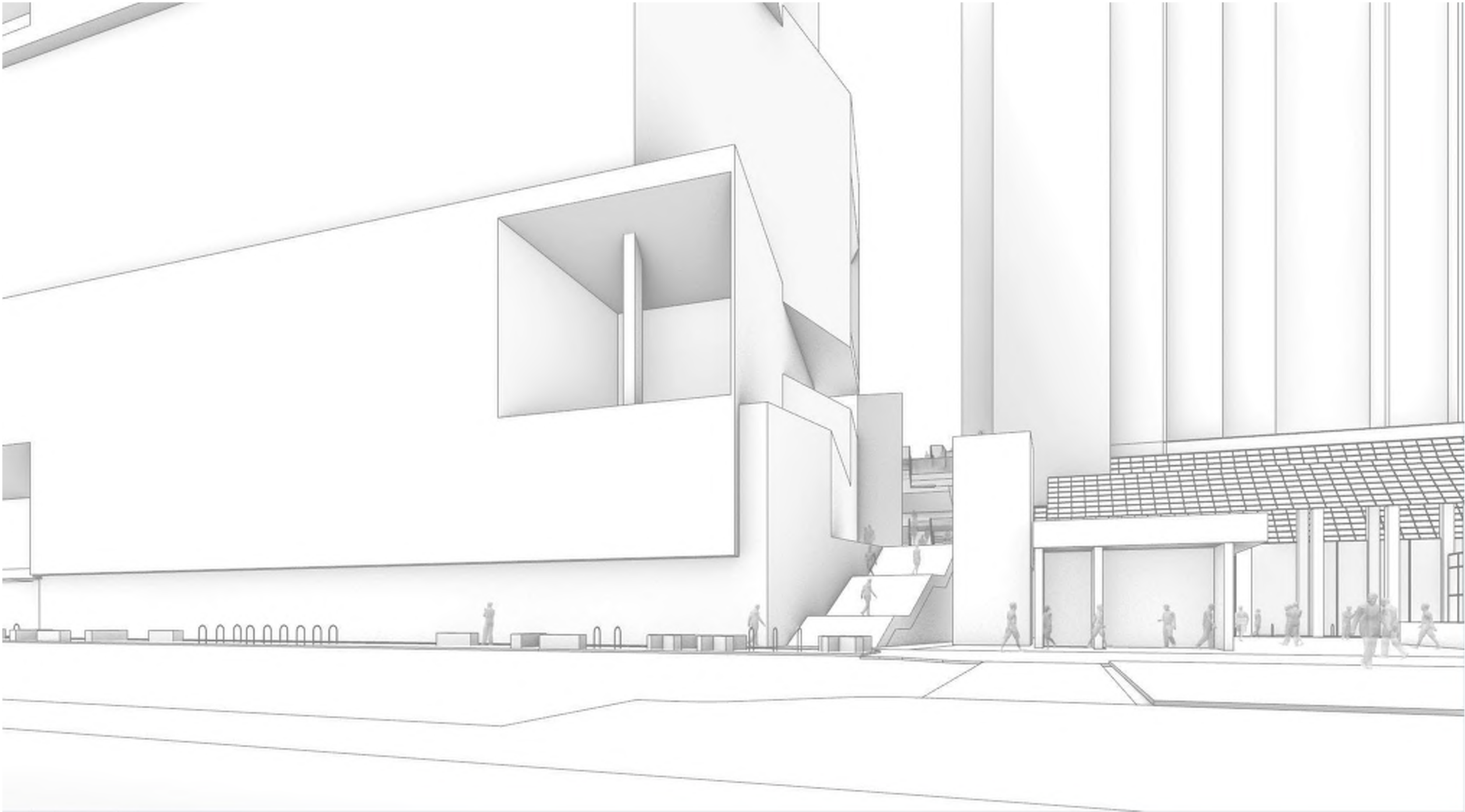

LEVEL 2 - ROOFTOP STAIR STUDIES - ALT 3

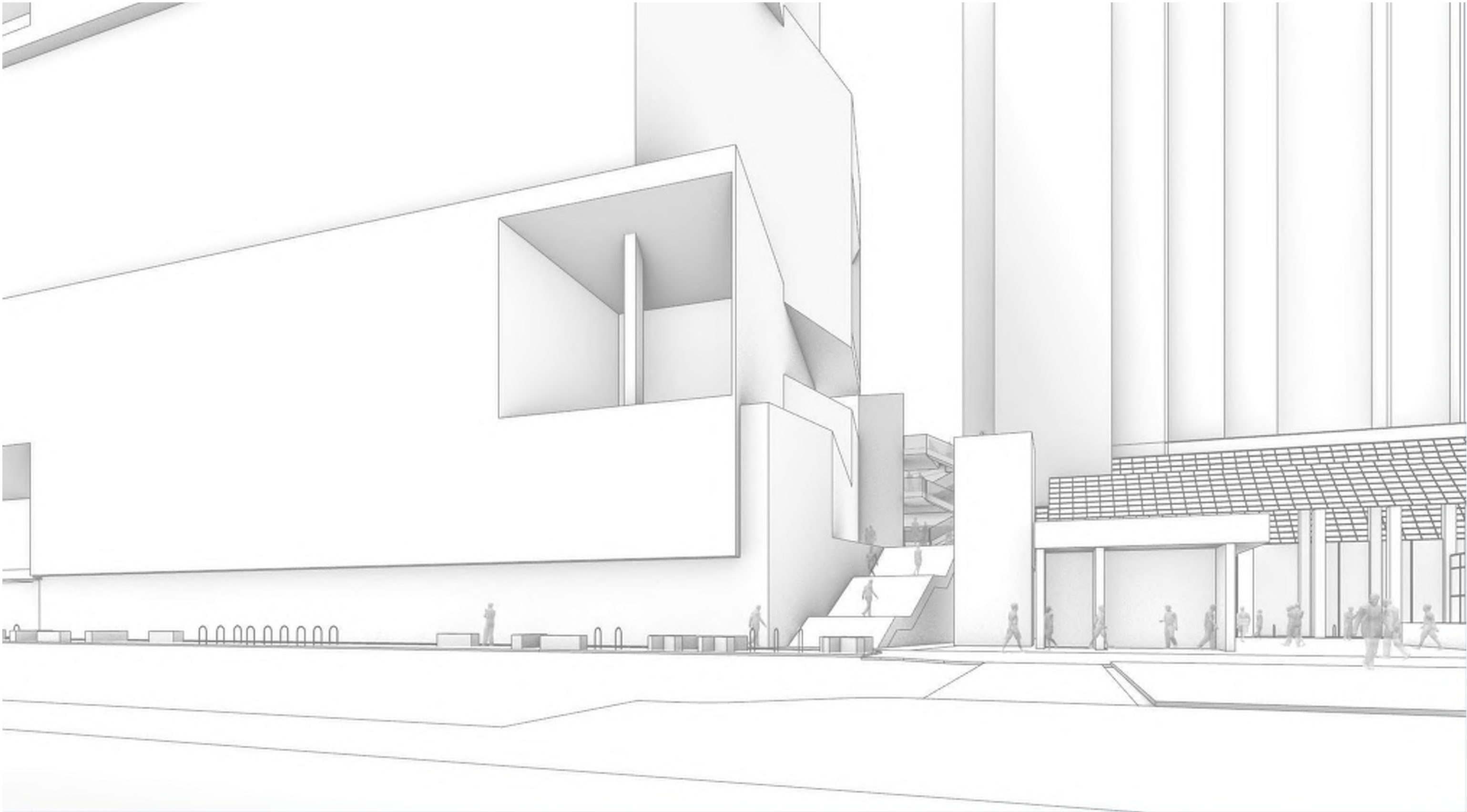

LEVEL 2 - ROOFTOP STAIR STUDIES - ALT 4

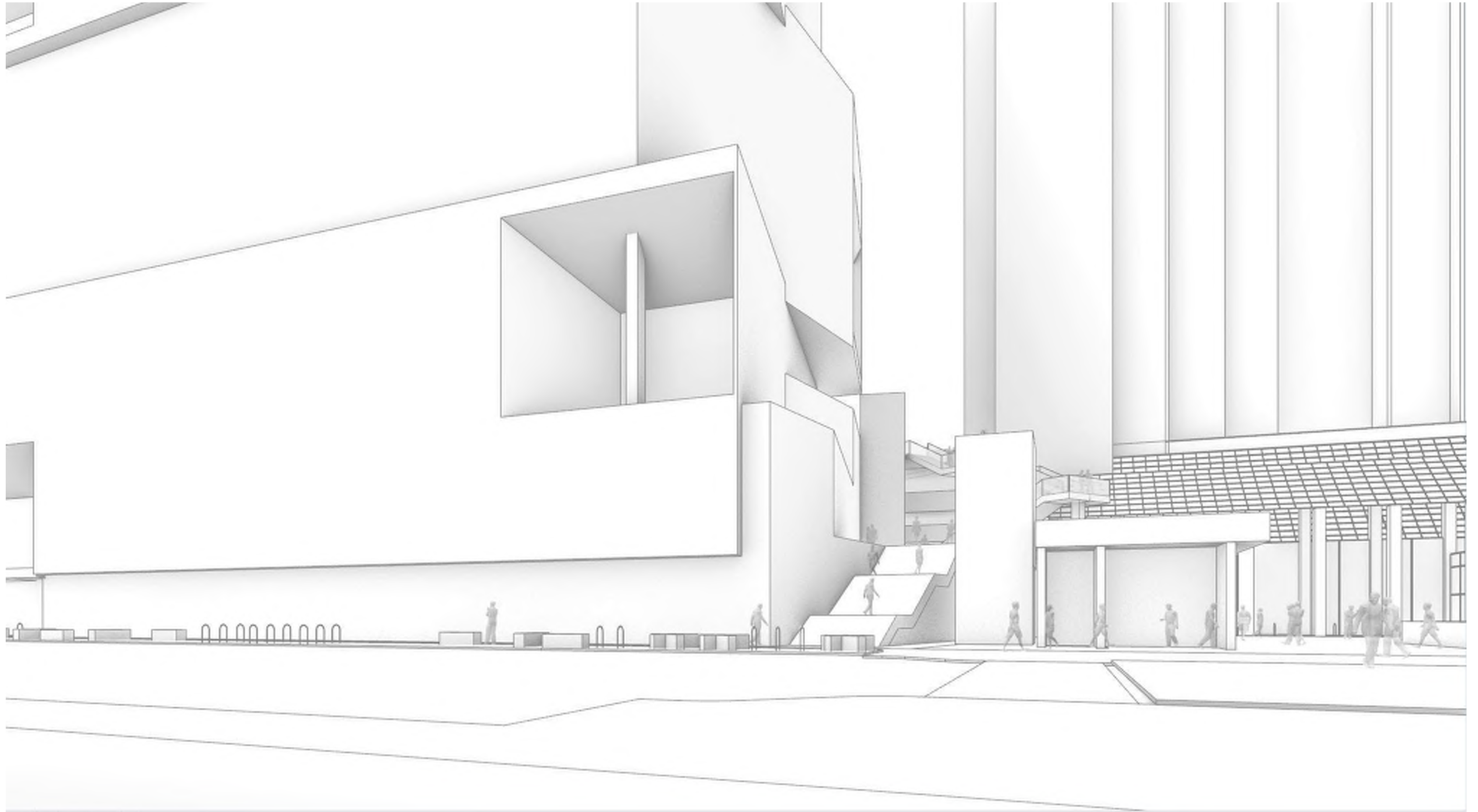

LEVEL 2 - ROOFTOP STAIR STUDIES - ALT 1

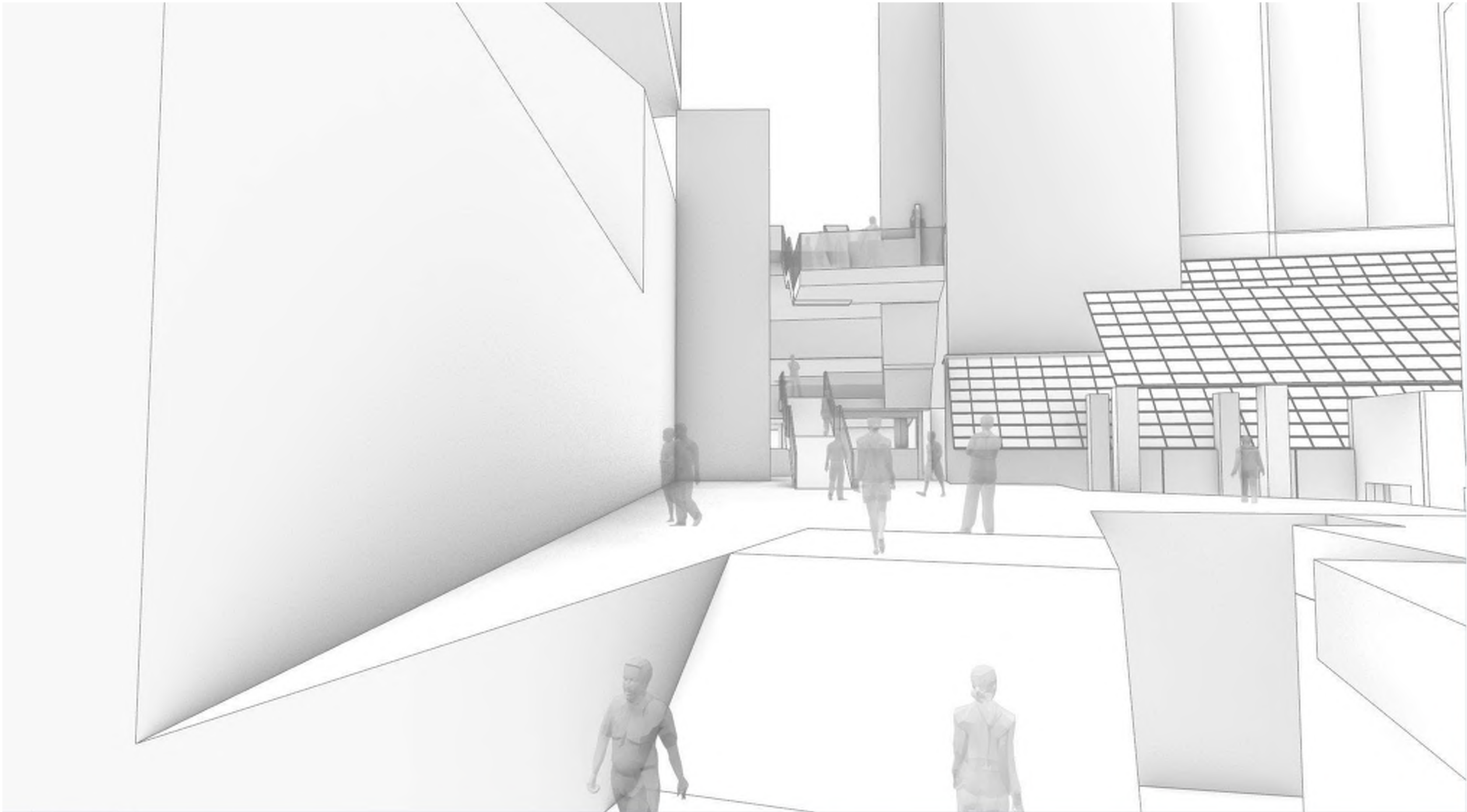

LEVEL 2 - ROOFTOP STAIR STUDIES - ALT 3

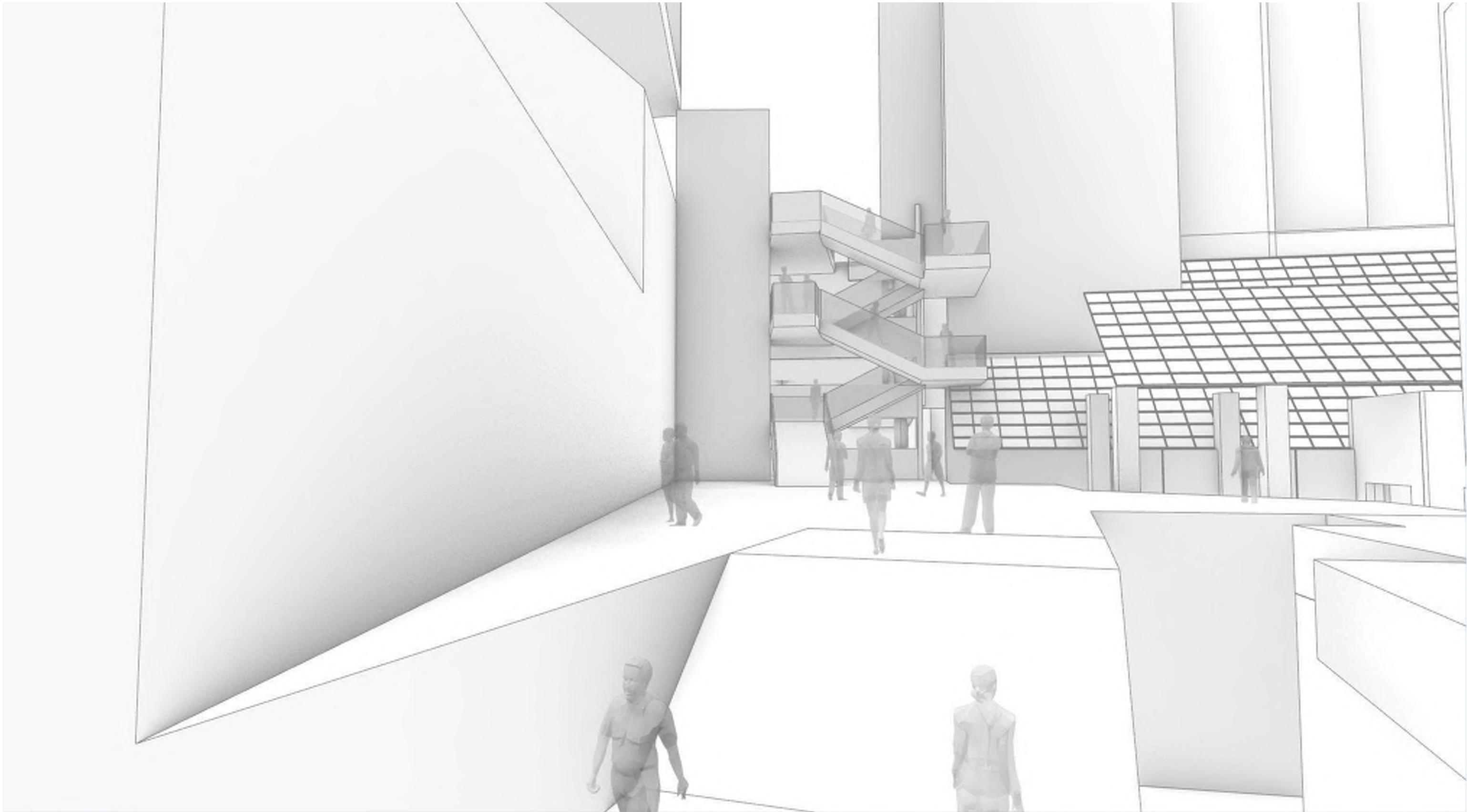

LEVEL 2 - ROOFTOP STAIR STUDIES - ALT 4

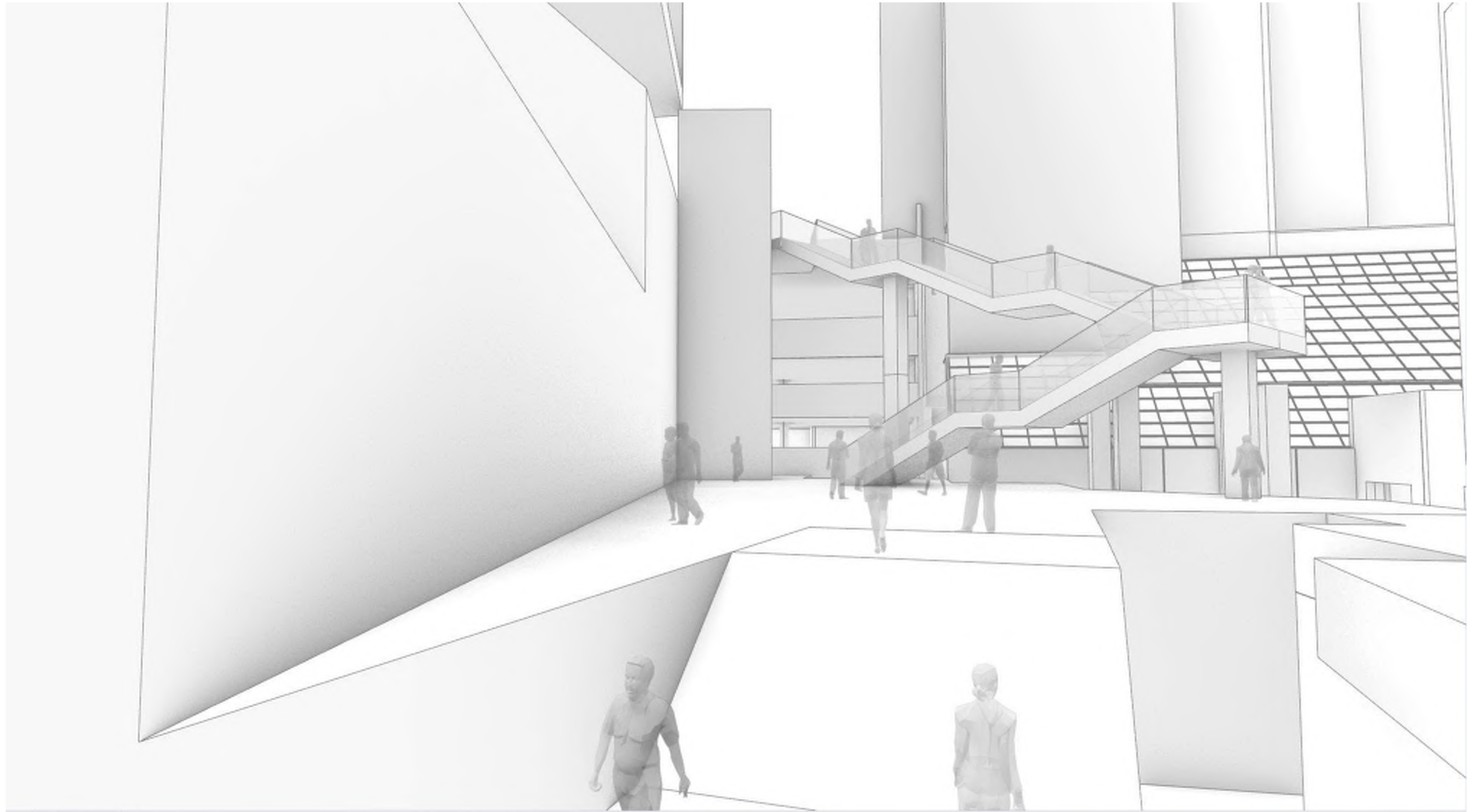

LEVEL 2 - ROOFTOP STAIR STUDIES - ALT 1

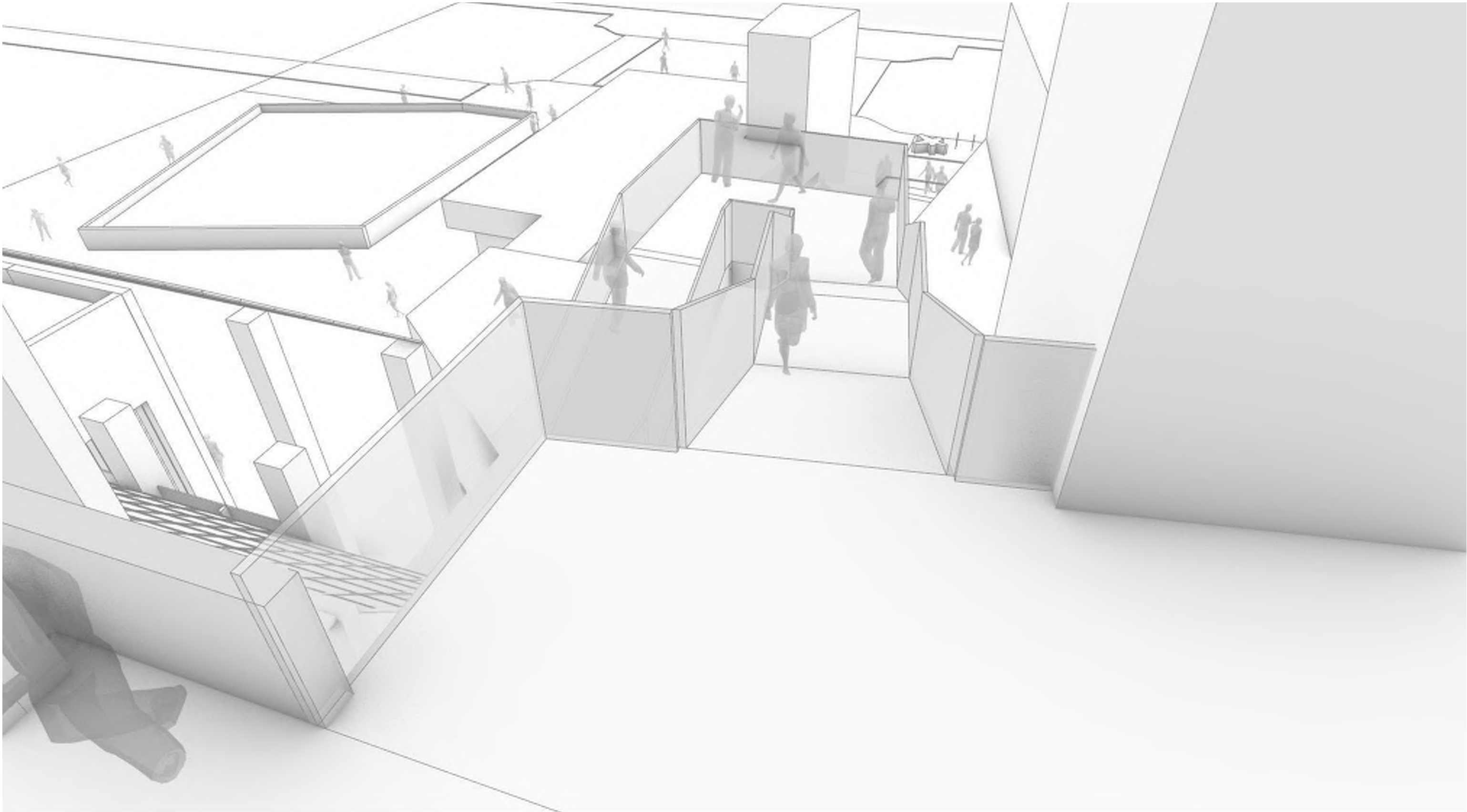

LEVEL 2 - ROOFTOP STAIR STUDIES - ALT 3

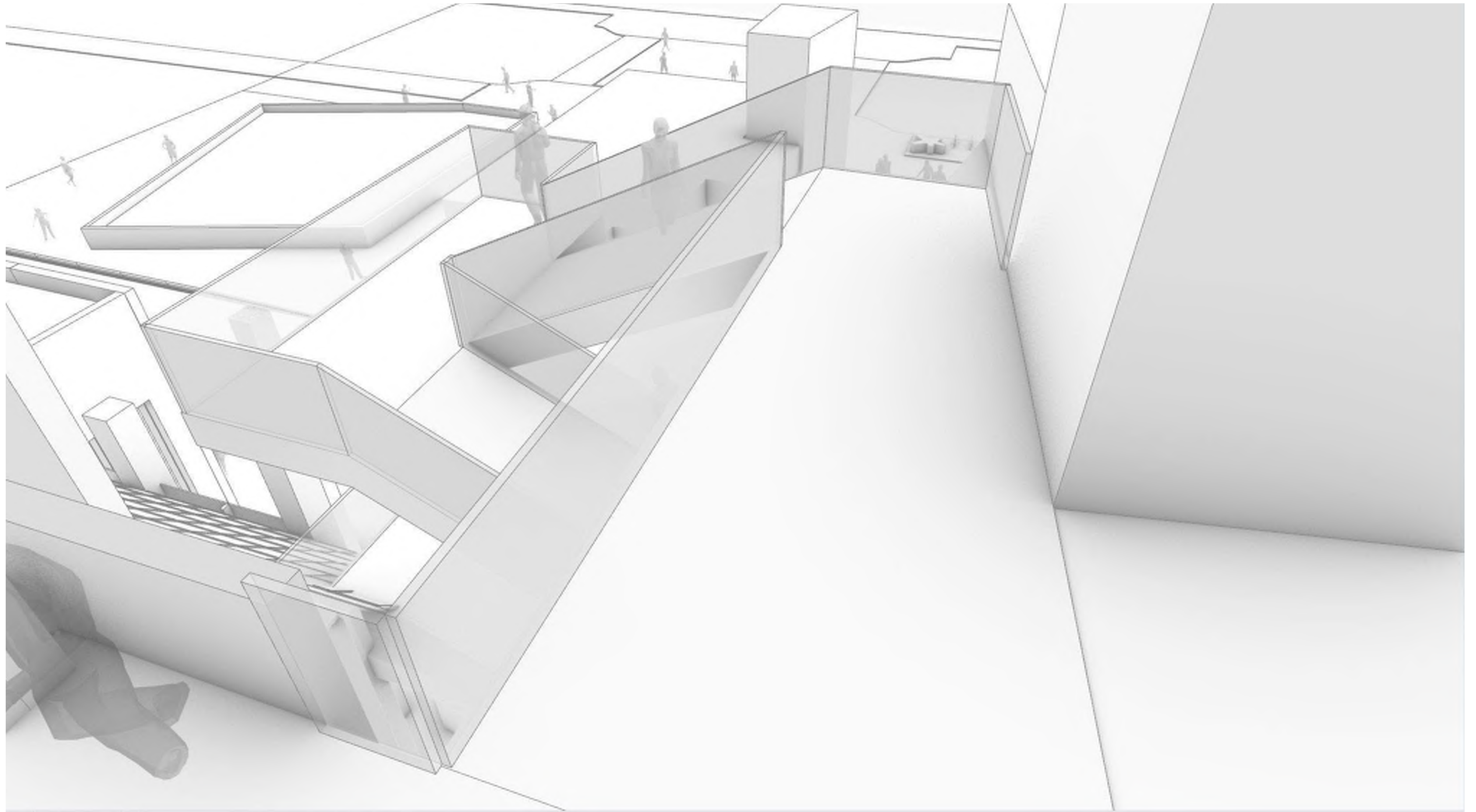

LEVEL 2 - ROOFTOP STAIR STUDIES - ALT 4

