

4. LANDSCAPE

4.1 145 BROADWAY LANDSCAPE

OPEN SPACE OVERVIEW

BROADWAY PARK

While Broadway Park is not contemplated to proceed in the same phase as 145 Broadway, it is described here to offer context to the wider finished master plan improvements. The existing park is between Broadway and the North Garage and is defined on the east and west sides by the streets that lead to and border the North Garage. The current grading slopes up from the south to north toward the existing parking garage separated from these streets by the grades. The park is further separated from these adjacent streets by the brick walls at the edges of the park. The existing entries to the park are limited to Broadway at the southeast and southwest corners and from the parking garage.

The redesign of the Broadway Park aims to expand the usable space of the park to the east and west toward the proposed new building at 145 Broadway, the existing building at 105 Broadway and the new building entries for residential at the north edge of the park. The expanded park space is expressed in the design with the park paving pattern extended into the adjacent streets, and installed in a flush condition. A change of color and texture, along with a couple of vertical elements along each side of the street, marks the travel ways.

The redesign also makes the park more permeable in response to pedestrian desire lines to and from the East West Pedestrian Connector north of 105 Broadway, and to and from the southeast corner of the park on Broadway toward the northwest. While the park redesign accommodates these pedestrian movements through the space, the redesign, first and foremost aims to make the park a more usable public space with multiple seating options and more ways to program and enjoy the park.

Along the eastern side of the park, a 50' long community table functions as a meeting place, lunchtime eating spot, outdoor work table, game table and outdoor classroom. The table and its seating are framed by rather tightly spaced, light leafed, canopy shade trees to create dappled light in the space. To extend the use of the community table into the evening, LED light strips form a pattern of illuminated lines overhead.

The planting is in a series of linear zones with a varied and mostly native palette of shrubs and perennials up to 3' or so in height as an understory, and canopy trees overhead. The planting creates a presence of nature in this urbanized area and is designed to create seasonal interest as well as define paths and subspaces. The central space of the park is an open and flexible lawn area suitable for programming.



THE CITYDECK GREEN BAY ([HTTP://WWW.STOSS.NET/](http://www.stoss.net/))



BYRANT PARK ([HTTP://WWW.NEWYORK.COM/](http://www.newyork.com/))



HARVARD YARD ([HTTP://WWW.MVVAINC.COM/](http://www.mvva.com/))



SMITH CARDIOVASCULAR RESEARCH BUILDING

145 BROADWAY LANDSCAPE

OPEN SPACE OVERVIEW

BROADWAY PARK

In addition to the seating at the community table, the park includes long wooden benches along the linear planting zones. Along the path at the north edge of the lawn, another elongated seating element is designed in a profile that corresponds to the reclined seating of a chaise lounge for relaxing in a south facing orientation.

At the north edge of the park along a key east west path, is a simple rectangular basin of water that is supplied from rainwater harvested from the site. Water drops via gravity into the basin from a series of water spouts along a low wall that separates the edge of the basin from the residential entries. The grading in the park directs surface runoff into the planting zones as recharge areas.

The key materials in the park include bands of concrete unit pavers in several colors on a concrete setting bed, over the walking surfaces and drives, as described above. The pavers in the driving surface will match the colors and pattern of pedestrian areas, but be a smaller paving module size to prevent breaking from vehicular travel. The rectangular space with the community table may have special paving such as stone.

145 BROADWAY (COMMERCIAL BUILDING A)

The design of the 145 Broadway streetscape along Broadway and Galileo Galilei Way has been developed in parallel with the design of Broadway Park. The planting zones along Broadway are aligned in front of 145 Broadway and Broadway Park to extend continuity of pedestrian walking zones as well as planting along Broadway. The eastern façade of 145 Broadway is splayed to open up the corner along Broadway at the street leading to the North Garage. The concrete unit pavers of Broadway Park extend to meet the eastern façade of 145 Broadway and along Broadway to engage the active use, thereby extending the park westward to position the entry and the active use at 145 Broadway as the western edge of Broadway Park.

The East West Pedestrian Connector north of 145 Broadway will have a 5' wide path from Galileo to the street flanking the North Parking Garage. The green space will be planted with trees and perennials that will function as a water receiving landscape.

145 BROADWAY STREETScape ON BROADWAY AND GALILEO GALILEI

The design of the 145 Broadway streetscape along Broadway and Galileo Galilei Way has been developed in parallel with the design of Broadway Park. The planting zones along Broadway are aligned in front of 145 Broadway and Broadway Park to extend continuity of pedestrian walking zones as well as planting along Broadway. Short term bicycle parking will be located along the Broadway streetscape framed with low planting and adjacent to easement c.

The eastern façade of 145 Broadway is splayed to open up the corner along Broadway at the street leading to the North Garage. The concrete unit pavers of Broadway Park extend to meet the eastern façade of 145 Broadway, thereby extending the park westward to position the entry and active use at 145 Broadway as the western edge of Broadway Park.

145 BROADWAY



LOOKING ALONG WATER BASIN TOWARD THE COMMUNITY TABLE

4.2.1 145 BROADWAY LANDSCAPE

SITE PLAN AND CONTEXT

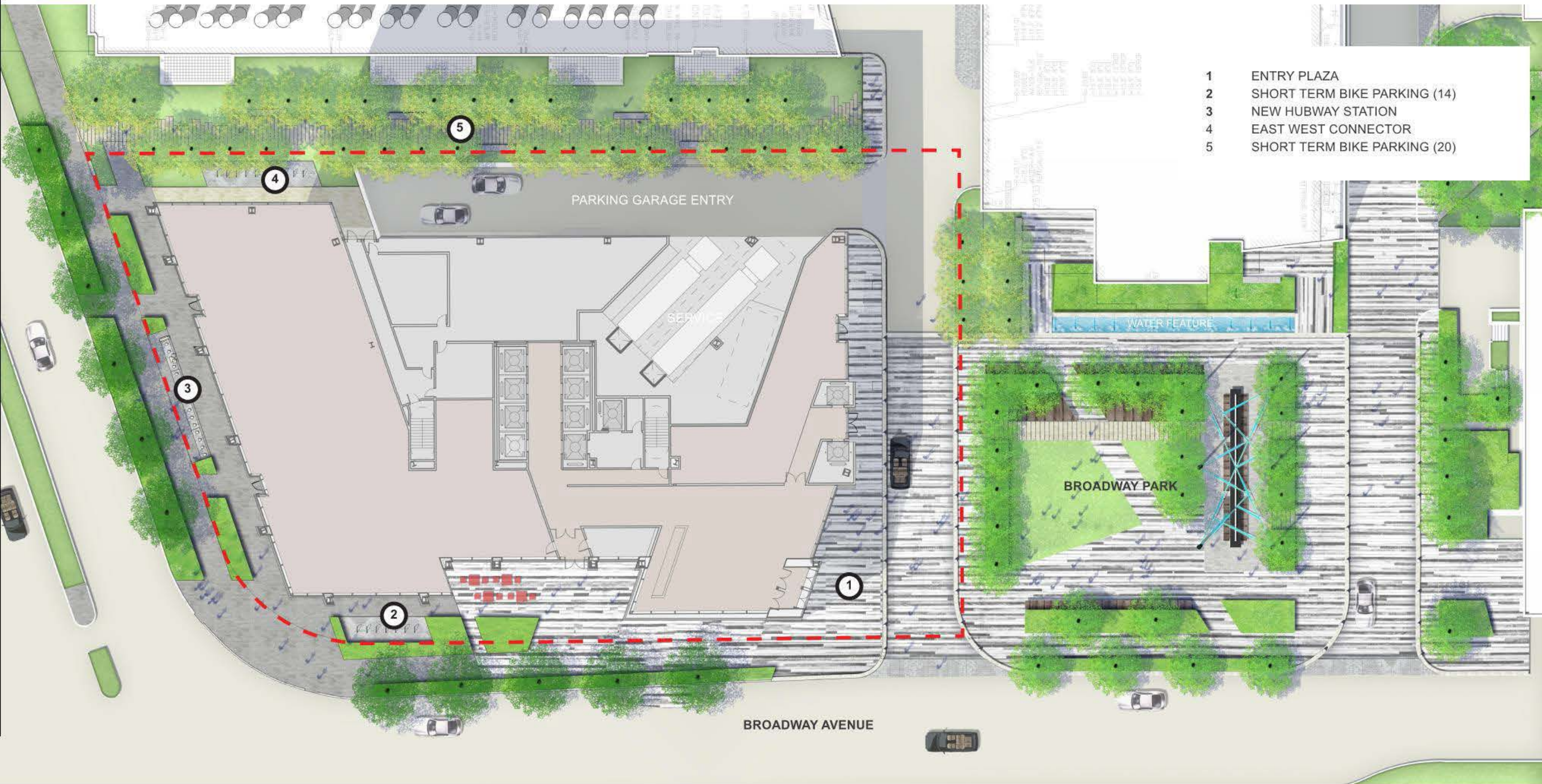

- 1 ENTRY PLAZA
- 2 SHORT TERM BIKE PARKING (14)
- 3 NEW HUBWAY STATION
- 4 EAST WEST CONNECTOR
- 5 SHORT TERM BIKE PARKING (20)

NOTE: DASHED RED LINE REPRESENTS THE LIMIT OF THE 145 BROADWAY DESIGN PROPOSAL FOR LANDSCAPE.

145 BROADWAY LANDSCAPE

SITE PLAN AND CONTEXT

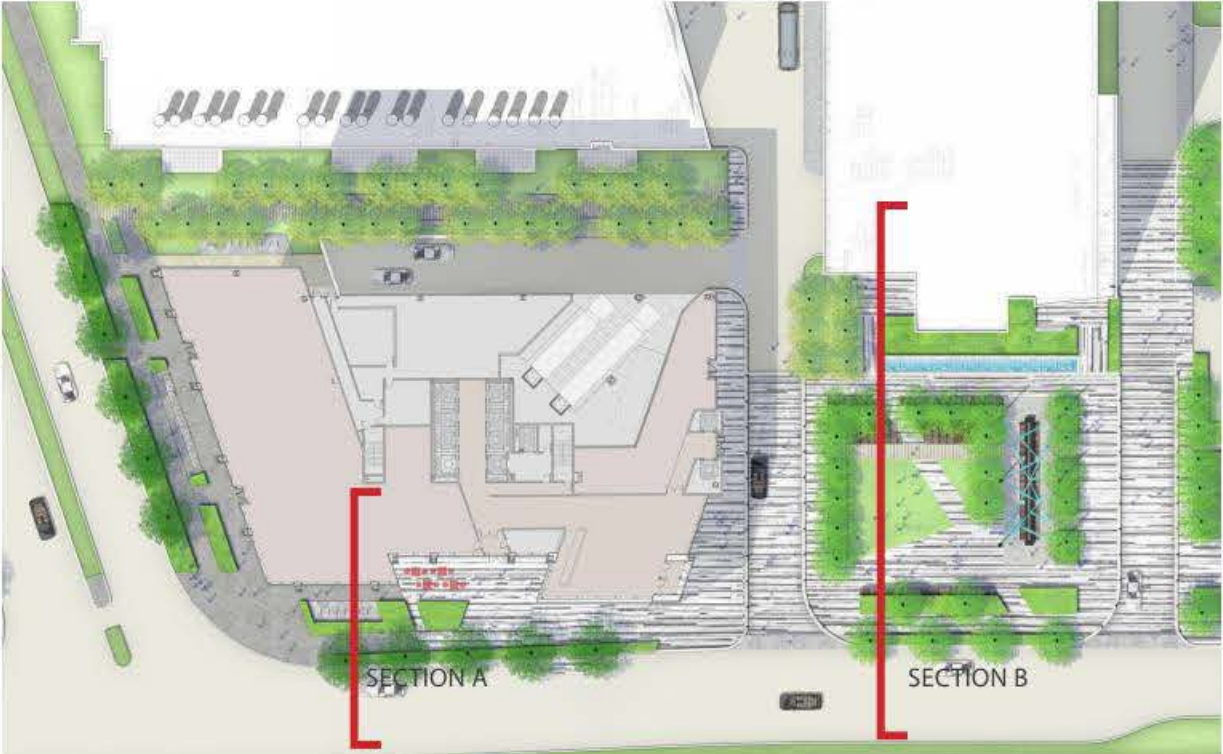

4.2.2 145 BROADWAY LANDSCAPE

ENLARGED SITE PLAN



NOTE: DASHED RED LINE REPRESENTS THE LIMIT OF THE 145 BROADWAY DESIGN PROPOSAL FOR LANDSCAPE.

4.2.3 145 BROADWAY LANDSCAPE

CONCEPT GRADING

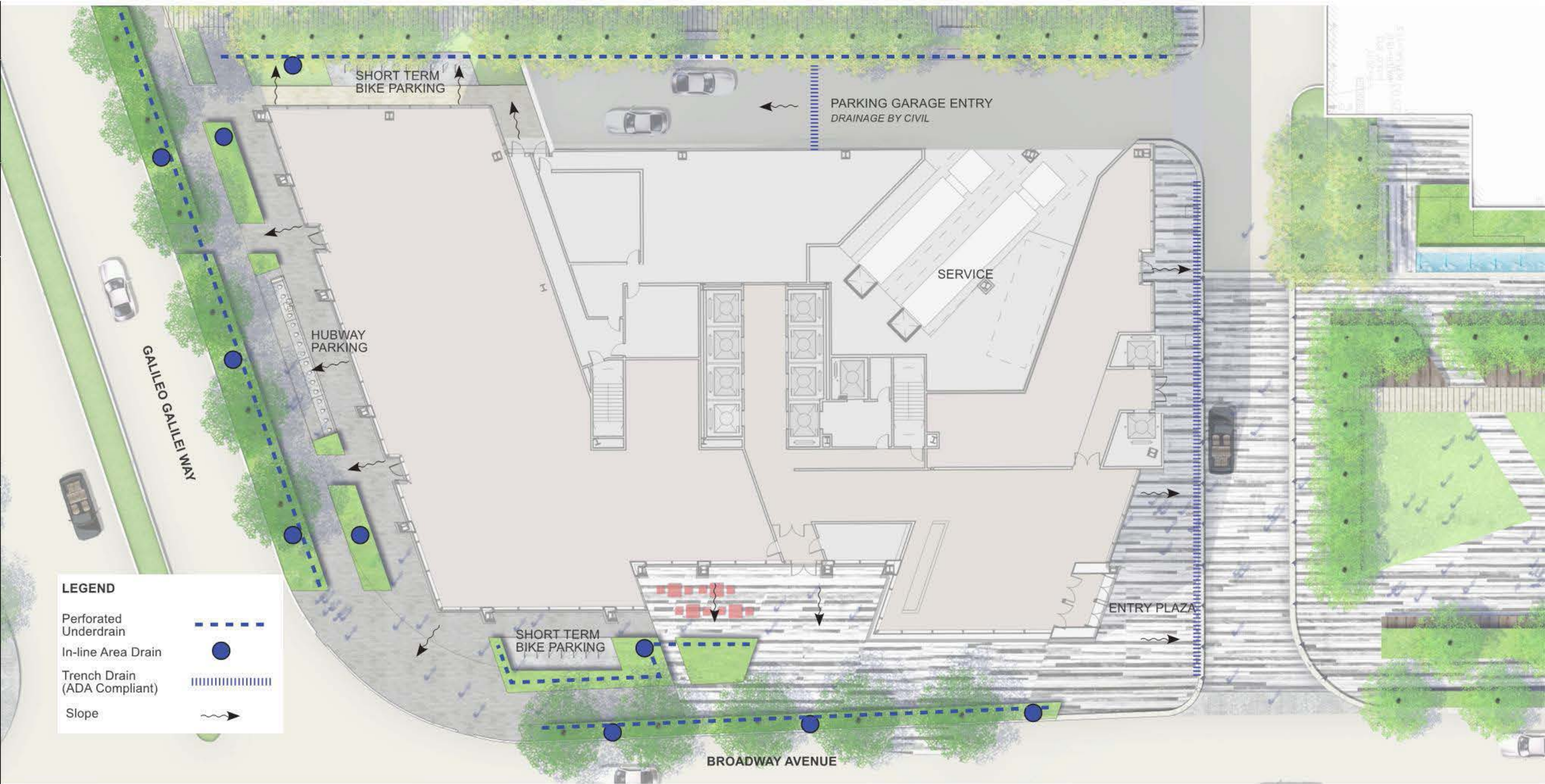

4.2.4 145 BROADWAY LANDSCAPE FURNISHINGS



LITTER RECEPTACLES



SEATING WALLS



CONCRETE UNIT PAVER

FURNISHINGS

BENCHES, TABLES, AND SEATING

Benches, tables and other types of seating should be located in a variety of setting to allow a choice of scenery and social settings. Within the district, a mix of fixed and movable chairs, as well as tables will be provided to allow for informal gatherings, outdoor eating, studying and socializing.

If located in sunny areas, umbrellas or shading devices will be considered.

In addition to movable tables and chairs, fixed benches may be used along the East West Connector, or potentially near building entrances, including vestibules, and other covered spaces.

SEAT WALLS

Within the district core, seat walls or colored concrete benches (with or without wooden seats) will be used to provide seating in or around the edges of these spaces. Walls shall be concrete and be compatible in material, pattern and color with immediately adjacent buildings. Capstones will be granite or precast concrete. Seat walls should be set level.

LITTER AND ASH RECEPTACLES

The litter receptacle that should be used throughout the district is the 'collect' as supplied by "landscapeforms," with top or side opening, or similar. Finish shall be polyester powder coat in color 'silver,' 'titanium,' or 'black,' matching the color chosen for the benches.

BICYCLE RACKS

In all district areas, the 'Bola Rack', or similar, shall be used. Racks should be anchored to a concrete base, and shall preferably be stainless steel, receive a hot dipped galvanized finish, or a powder coat finish in black. Spacing of t

4.2.5 145 BROADWAY LANDSCAPE PAVING



CONCRETE UNIT PAVER

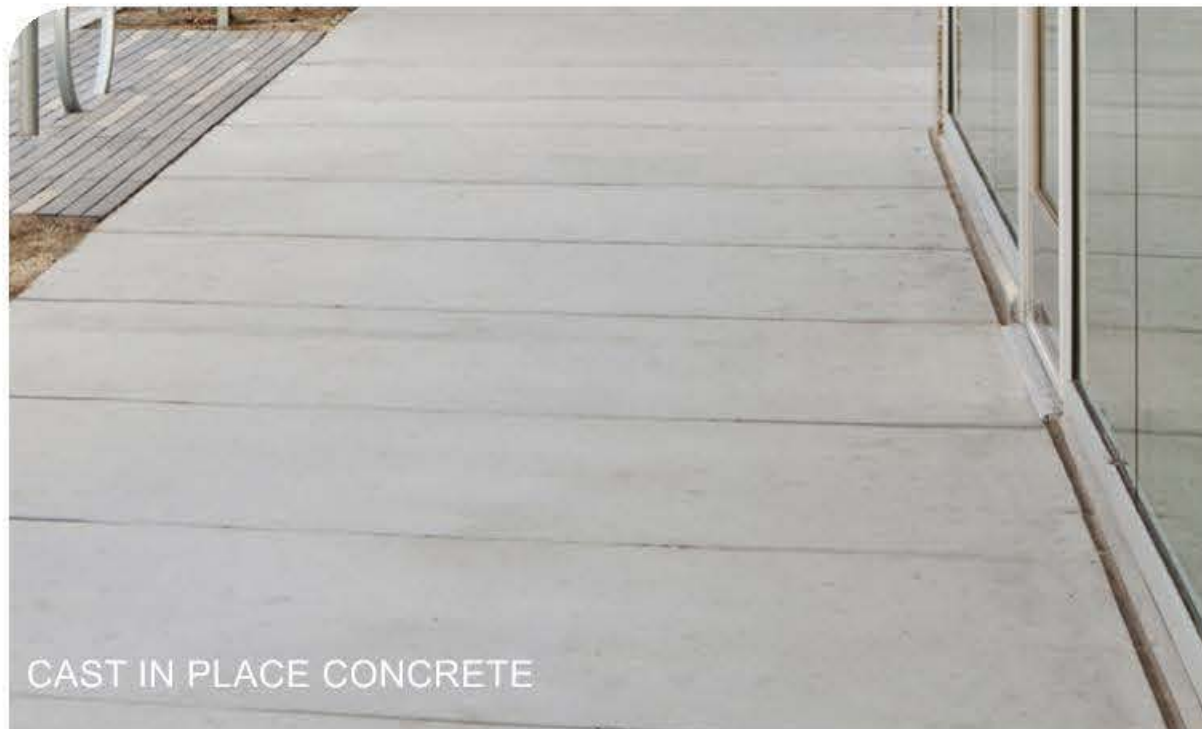

CAST IN PLACE CONCRETE



CONCRETE UNIT PAVER

All paving materials should be able to withstand high volumes of pedestrian movement and withstand harsh weather conditions. Paving should be able to accommodate garage entrances, retail loading areas, vehicular crossings, and potentially de-icing treatments, if needed. In the event of damage, repair or utility work, paving should be easily repairable. Pavements must be slip resistant and safe for pedestrian traffic. Paving that utilizes lighter coloring can help reduce heat island effect and can count towards LEED credits. The following are pavement recommendations:

Field paving should be predominantly used to minimize tripping hazards along the pedestrian movements. Pave the sidewalk predominantly with field paving to minimize tripping hazards in the pedestrian travel way.

Specialty paving should be used to highlight entries to buildings or park, mid-block crossings or even public art. Paving over tree spaces should be porous, either by utilizing porous pavers, setting unit pavers on a pervious setting bed or using tree grates.

Within the district, concrete pavers may be used along the eastern facade of 145 Broadway, adjacent to Broadway Park to signify primary building entries and stairs. Sidewalks along Broadway, and Galileo Galilei Way will typically be cast in place concrete with saw cut joints, scoring patterns, and/or texture. Decomposed granite and or a Flexi-pave surface material could be considered an option for surfacing below bicycle parking. Paving shall be generally consistent with the sample photos shown or approved equal by city staff.

4.2.6 145 BROADWAY LANDSCAPE LIGHTING



AMENITY LIGHTING



FULL CUTOFF STREETLIGHT / PEDESTRIAN



POST TOP PEDESTRIAN LIGHT

LIGHTING

The primary function of exterior lighting is the safety of drivers, cyclists and pedestrians at night, but it plays an equally important role in complementing architecture and urban form to provide a sense of place before and after sunset. Exterior lighting sources shall be light emitting diode (LED), unless approved by city staff. All exterior lighting fixtures must be submitted and approved by the CRA and city staff. Developments in the district shall observe the following guidelines with respect to exterior lighting:

Building lighting – Exterior walls of buildings should be illuminated at a regular interval by wall-bracketed or accent light fixtures, and such fixtures should complement the building's architectural expression. Where a feature such as a soffit or arcade is employed in the architectural design of a building, lighting should be recessed into that feature. Exposed light sources shall not be permitted around buildings.

Pedestrian lighting – Pedestrian light fixtures should be no more than 14 feet (14') tall, and be anchored by a pedestal base that is of proportion to the height and circumference of the pole of a complementary material. Louis Poulsen Kipp are recommended for pedestrian areas.

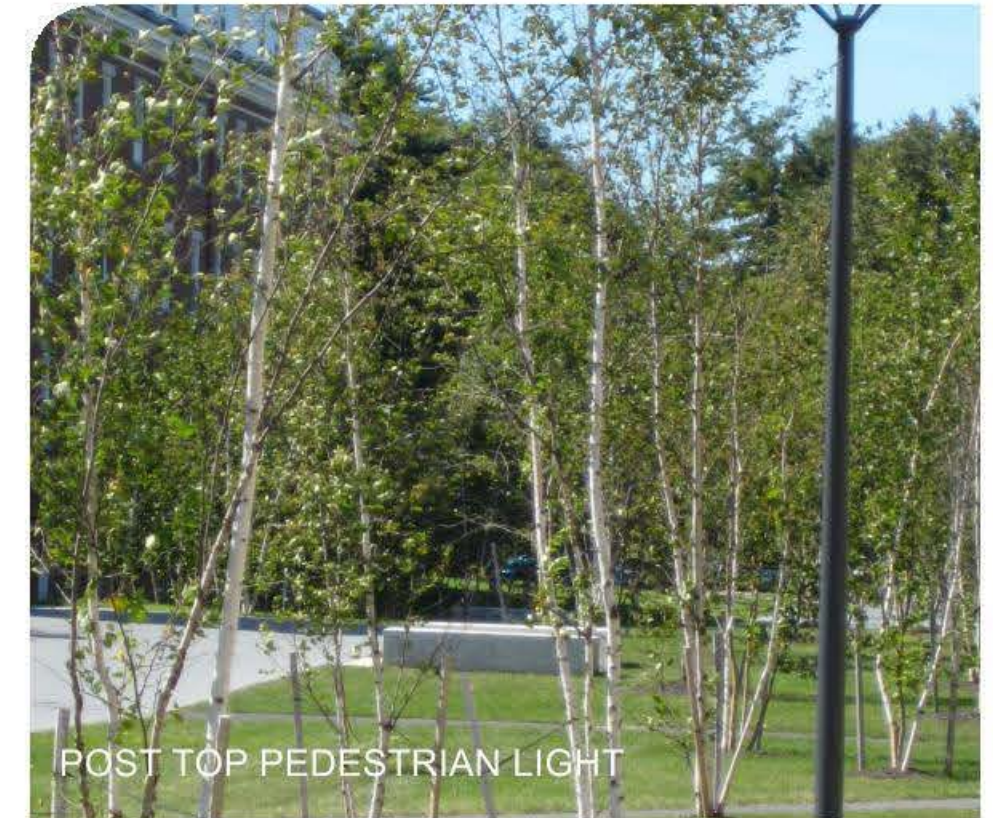

POST TOP PEDESTRIAN LIGHT

4.3.1 145 BROADWAY LANDSCAPE PLANTING

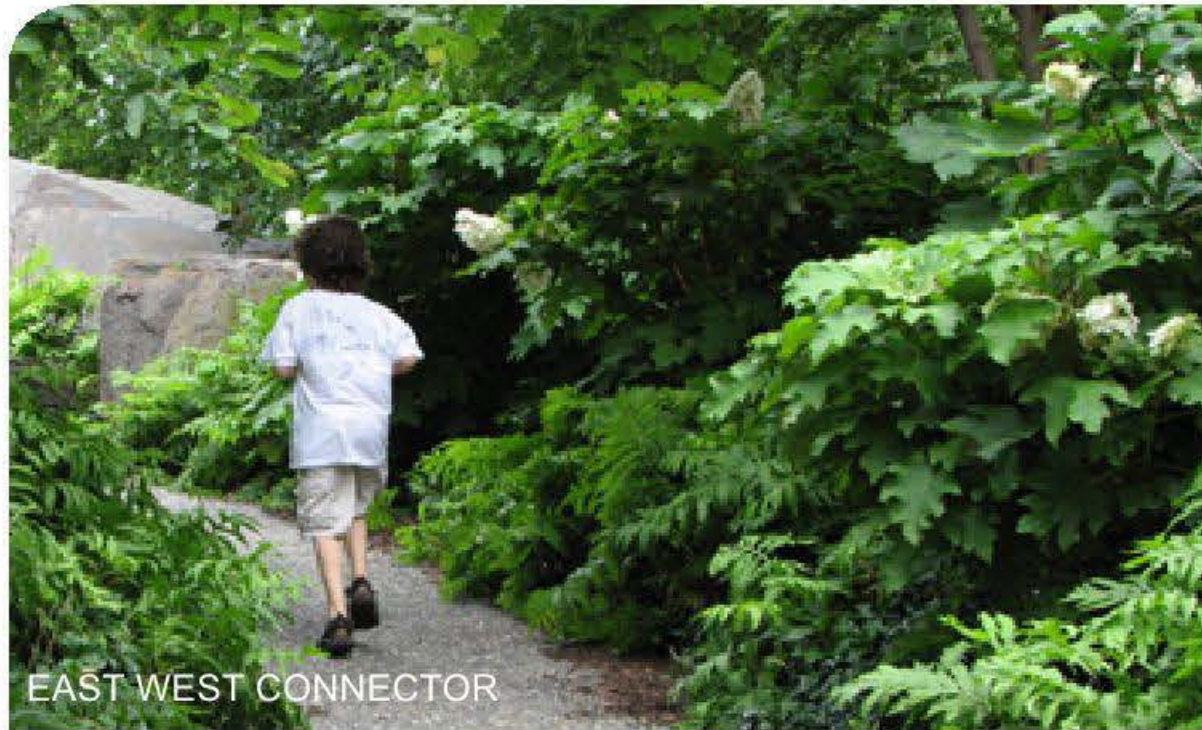

EAST WEST CONNECTOR



EAST WEST CONNECTOR

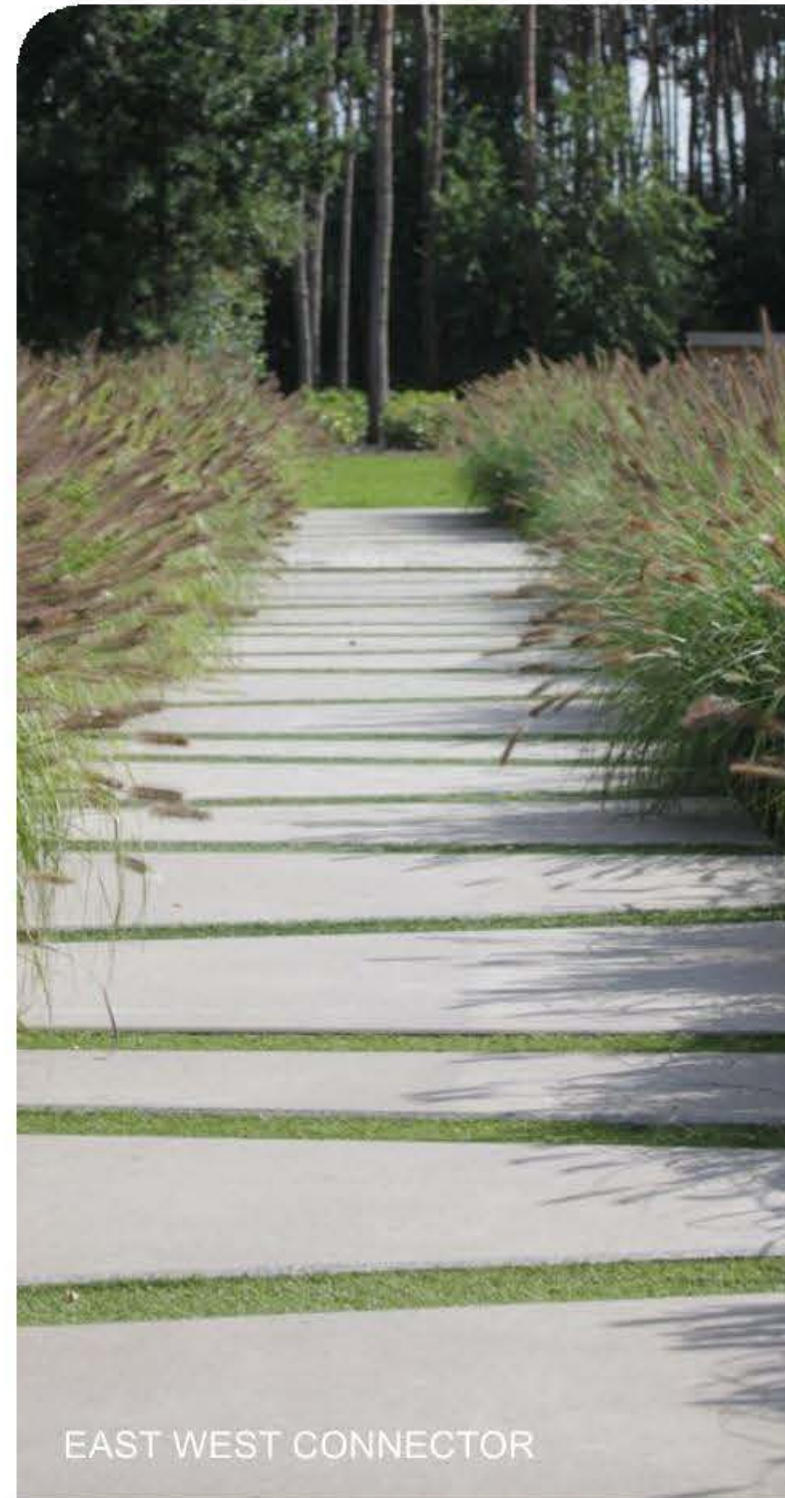

EAST WEST CONNECTOR

PLANTING

TREES

Canopy shade trees serve a host of environmental purposes from influencing microclimates around buildings and pedestrian zones, to humanizing the scale of exterior spaces. Shade trees will be provided along streets, pedestrian walks and the public plaza. Shade trees shall be provided in accordance with the Landscape Plan. As indicated in the landscape plan, the Applicant shall provide a shade trees adjacent to the Dog Run, and a minimum of 6 shade trees within the Mews. The shade tree environment shall be generally consistent with the sample photos shown but can be replaced with a comparable substitute with Staff approval.

STREET TREES

Street trees shall be provided in accordance with the Landscape Plan. Trees on Broadway, and Galileo Galilei Way will follow the City of Cambridge Street Tree planting requirements.

SEASONAL PLANTING

The Applicant shall maintain seasonal planting beds along Broadway and Galileo Galilei Way, along the East West Connector and at the entry plaza fronting Broadway Park. The planting shall be generally consistent with the types shown. The plantings will vary by the season to provide interest at most times of the year.

145 BROADWAY LANDSCAPE

PLANTING



Polygonatum biflorum
Solomon's seal

Variegated Solomon's Seal handles 2-3 hours of direct morning sunlight in the Southern Appalachian region (USDA hardiness zones 6 and 7) if the soil is kept evenly moist. It grows 18 to 24 inches high and 3 to 4 feet wide in 10 years.

2-3" soil media



Viburnum acerifolium
Maple-leaved viburnum

Maple-leaf viburnum has long been cultivated for its attractive summer flowers, then the autumn leaves turn rose-purple and contrast with the mature dark fruits. The plants will thrive in moist soils and a range of light conditions but they are a good choice for dry soils in deep shade

6"- 1' soil media



Polystichum acrostichoides
Christmas fern

Typically grows in a fountain-like clump to 2' tall and features leathery, lance-shaped, evergreen (green at Christmas time as the common name suggests) fronds. Stocking shape of the pinnae also suggests Christmas. Evergreen fronds provide good winter interest for the landscape.

2-3" soil media



Trillium grandiflorum
White Trillium

Typically grows in height between 66'-100'. s. It is most commonly found on moist, fertile soils near streams and lakes. It is tolerant of flooding and also is drought-resistant and somewhat tolerant of salinity.

2-3" soil media



Maianthemum racemosum
False Solomon's Seal

This clump-forming perennial, while typically found in the forest, can also be enjoyed in the garden. As the plants emerge in the spring the stems arch from the ground to a height of 2'-3' bearing dark green alternating leaves which are 6" long and 3" wide.

2-3" soil media



Mertensia virginica
Virginia bluebells

An erect, clump-forming perennial which grows 1-2' tall and features loose, terminal clusters of pendulous, trumpet-shaped, blue flowers (to 1" long) which bloom in early spring. Foliage dies to the ground by mid-summer as the plant goes dormant.

2-3" soil media

4.3.2 145 BROADWAY LANDSCAPE

TREE SPECIES LIST



Gleditsia triacanthos var. inermis *Honey Locust*

Typically grows in height between 66'-100'. s. It is most commonly found on moist, fertile soils near streams and lakes. It is tolerant of flooding and also is drought-resistant and somewhat tolerant of salinity.

30" soil media



Serviceberry
Amelanchier x grandiflora

Typically grows in height between 15-25'. Multi-stemmed large shrub or small tree with a rounded crown of many small branches. Prefers moist, well-drained, acidic soils.

30" soil media



Sassafras
Sassafras albidum

Can grow in height between 30' to 60'. It grows best in open woods on moist, well-drained, sandy loam soils. Although adapted to dry, sandy soils, they do best in moist, fertile soils in partial to full shade.

30" soil media



Cucumbertree Magnolia
Magnolia acuminata 'Elizabeth'

Typically grows in height to 40' to 70'. Best grown in moist, organically rich, well-drained loams in full sun to part shade. Generally intolerant of soil extremes (dry or wet). Intolerant of most urban pollutants. May take 12 or more years before first blooms appear

30" soil media

5. DESIGN GUIDELINES

5.1.1 BUILT FORM

ARCHITECTURAL IDENTITY

Built Form

The existing Kendall Square embraces various styles of developments, each symbolizing the predominant economy of different eras: industrial and manufacturing, R&D, and now, the knowledge economy. Recently, companies are increasingly seeking buildings with large floor plates to allow greater flexibility to accommodate multiple disciplines, and to provide opportunities for interaction, collaboration, and creativity.

a. Architectural Identity of Kendall Square

Goal: Architectural composition should particularly emphasize a distinct identity for the building as well as for Kendall Square. This identity should be legible from adjacent streets and critical viewpoints, as well as within the overall Kendall Square skyline when seen from a distance.

Measure: Methods of creating a distinct architectural composition include use and proportioning of materials, colors and shapes that differ from those of adjacent buildings.

Goal: Design buildings to help create streetwalls, where appropriate, to help frame the sidewalks, plazas, and other public spaces in Kendall Square.

Measures:

- a. Align new facades with existing ones if doing so helps give a sense of spatial cohesiveness to the sidewalks.
- b. Allow breaks in the streetwall if needed to help define entryways to buildings.
- c. Streetwall design should take into account the need to provide active ground floor uses.

Goal: Convey the act and spirit of innovation in Kendall Square through transparency that directly reveals activity and displays visual media.

Measures:

- a. Use transparent building materials.
- b. Install media displays that show the works being done inside the buildings; avoid “advertising” imagery
- c. Install interactive media to bring cutting-edge technology closer to the public, directly revealing the scene of innovators at work

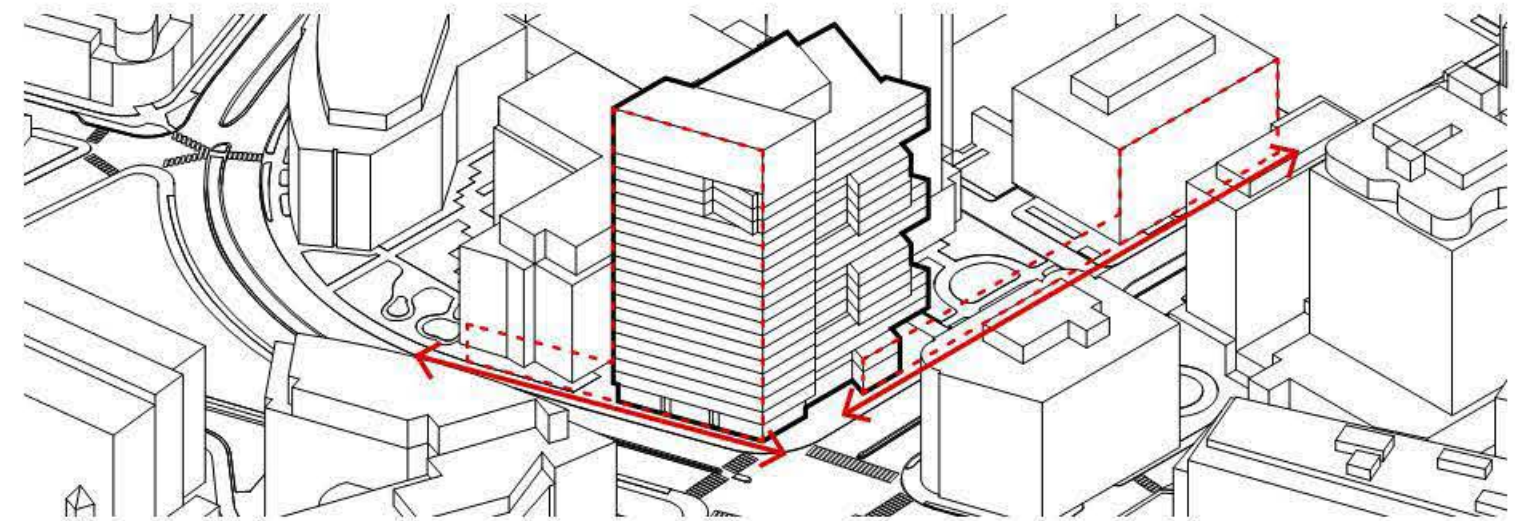

a. Building facades align with existing buildings, giving a sense of spatial cohesiveness to the sidewalks.

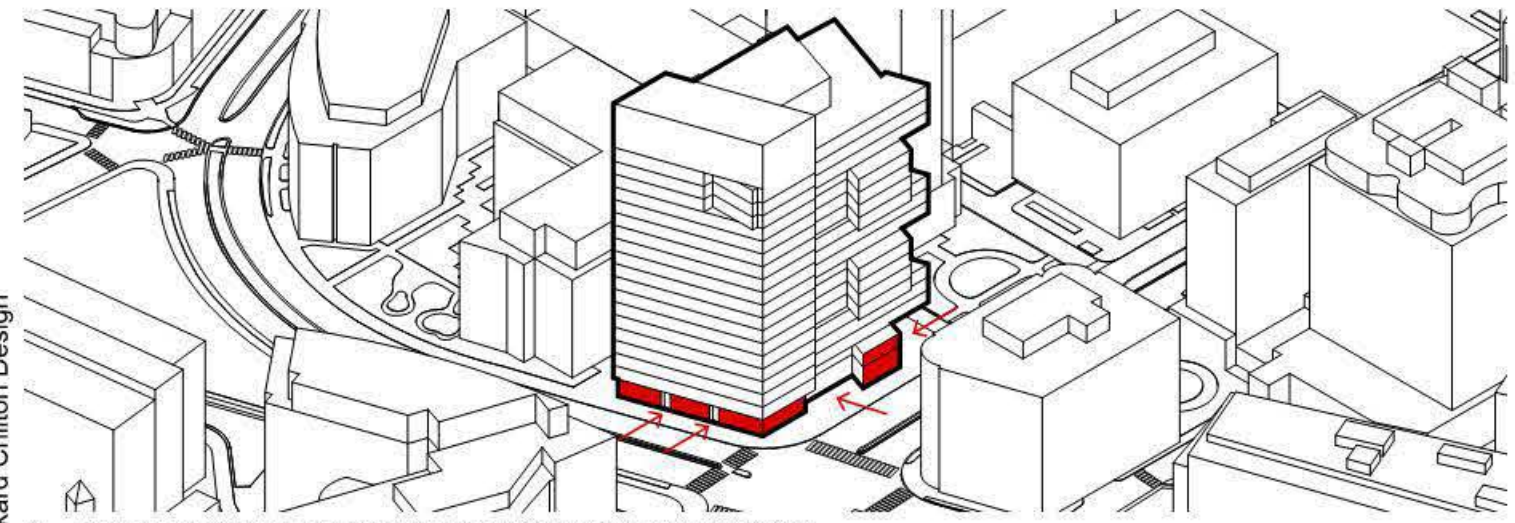

b. Breaks on the streetwall help define entryways to the building.

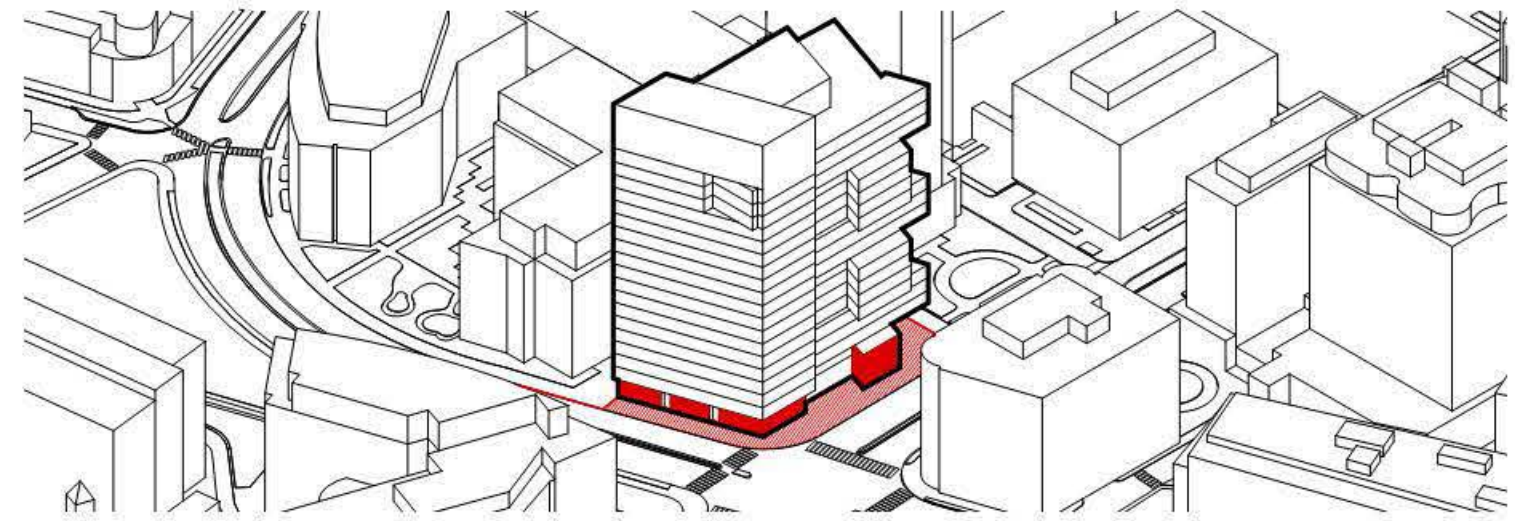

c. Setback for cafe seating and transparent streetwall design provide more opportunities for active ground floor uses.

Kendall Square Design Guideline
Pickard Chilton Design

5.1.2 BUILT FORM

SCALE AND MASSING

Scale and Massing

Goal: Design buildings to minimize monolithic massing and break down the scale of large buildings

Measures:

- a. Generally, buildings should have a clearly expressed base, middle, and top. This division should be expressed within the streetwall height zone as well as for buildings exceeding streetwall height.
- b. Pay special attention to the first floors (bottom 20 feet) of buildings, where buildings relate the most to the street and pedestrians. Different design guidelines may be applicable depending on location and uses of buildings.

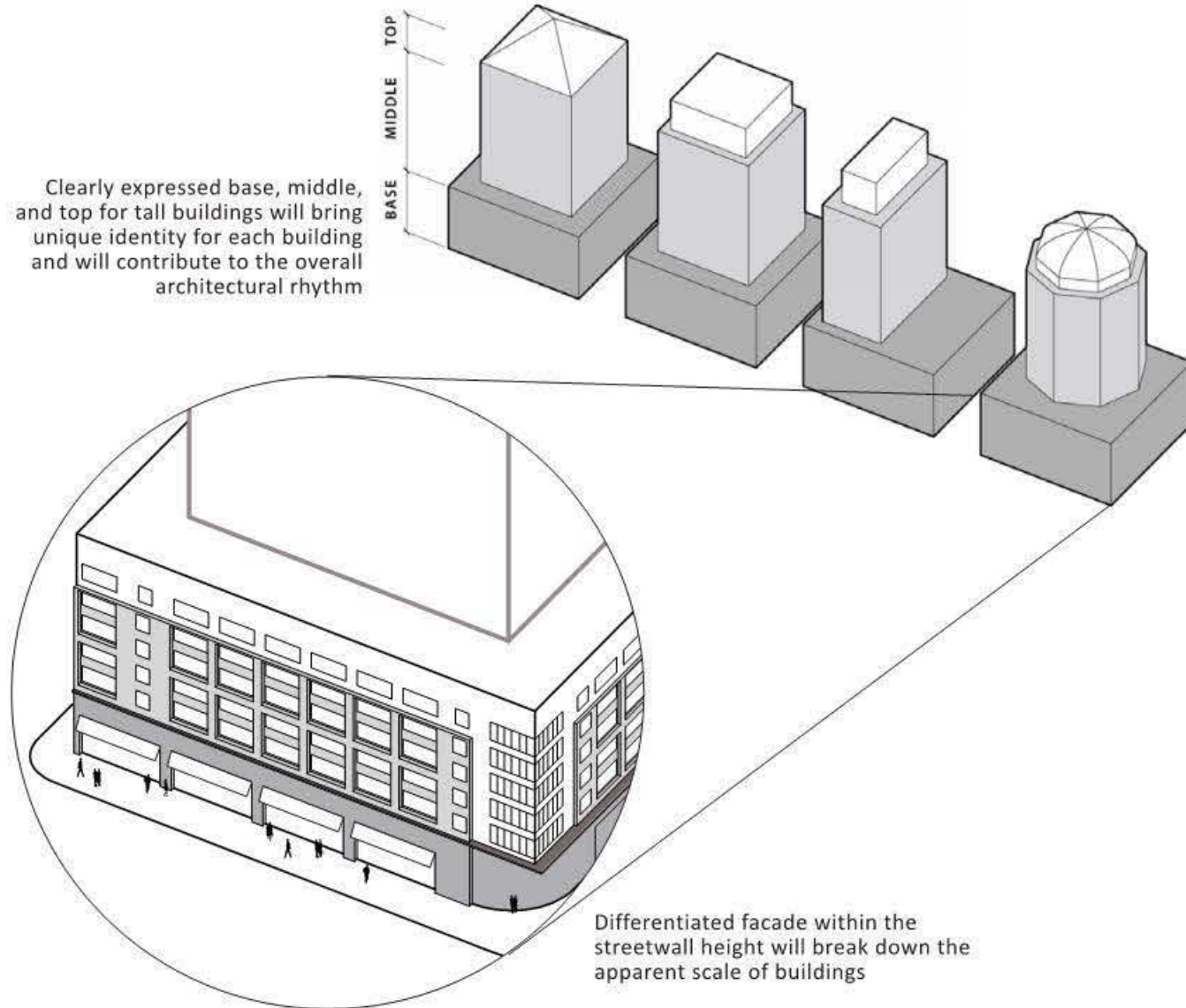

Kendall Square Design Guideline
Pickard Chilton Design

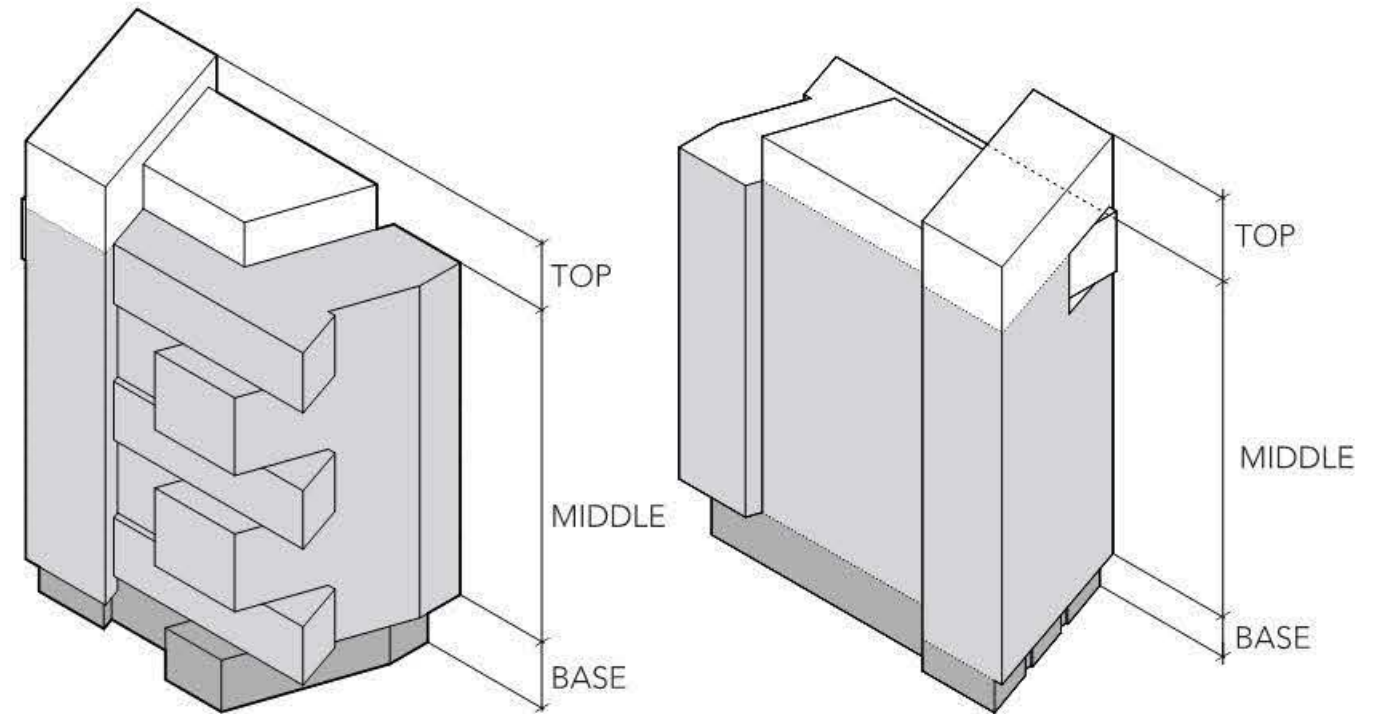

a. Massing is organized to clearly express a well defined base, middle, and top.

5.1.3 BUILT FORM

PARK EDGES

Park Edges

Goal: Development around parks and plazas should support an environment that is active, safe, and welcoming to a wide spectrum of users throughout the day, week and year.

Measures :

- a. Pay special attention to **scale and shadows of buildings along park edges.**
- b. Set back about two-thirds of the building façade above 85 feet from the principal façade depth of approximately 15 feet
- c. **Create vertical breaks for building volumes above 120'** in height facing the park -- façades facing the park exceeding 100' in width should be separated from adjacent façades by a gap of approximately 50 feet, extending back 50 feet from the ground level façade. Residential balconies may project up to 4 feet into setbacks and gaps.
- d. Façade areas without setback may be appropriate at corners or in specific locations to create architectural variety.

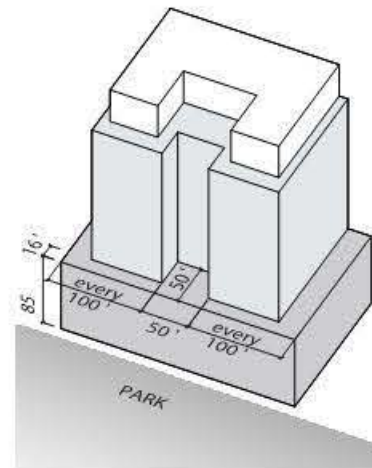

Example of a building massing located at park edges

Kendall Square Design Guideline
Pickard Chilton Design

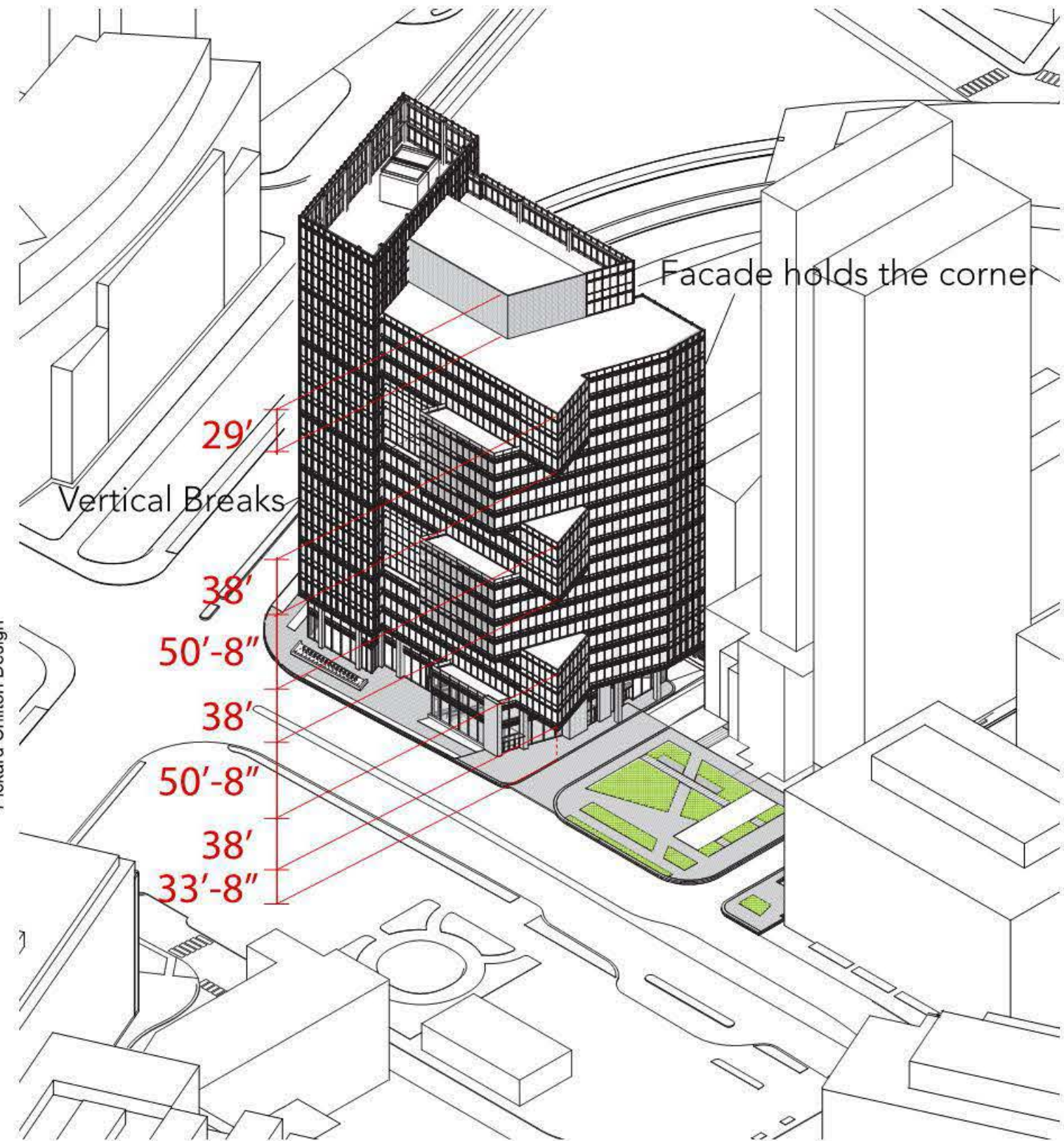

c. Vertical breaks are created for the building volume above 33' in height facing the park -- facade facing the park exceeding 100' in width has been separated from adjacent façades by a gap which is 51' wide.

5.1.4 BUILT FORM

VISUAL INTEREST

c. Visual Interest

Goal: Buildings should reflect a rhythm and variation appropriate to the urban context.

Measures:

- a. Express bay widths of 16 to 25 feet in predominantly residential areas and 25 to 50 feet along edges where commercial and institutional uses are prevalent.
- b. Establish an urban rhythm by creating a major vertical break for every 100' of façade length with a displacement of approximately 8' in depth or that divides building form into major distinct massing elements.

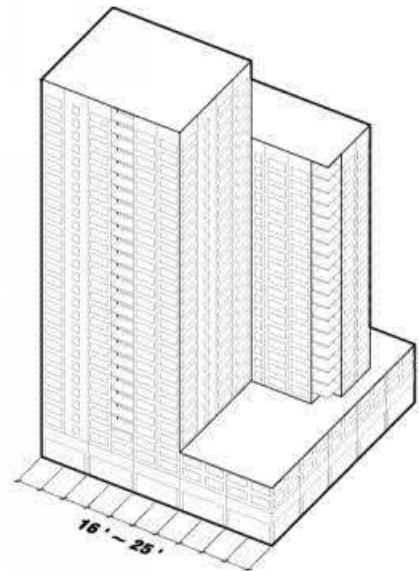

a. Bay widths of 16 to 25 feet for residential uses

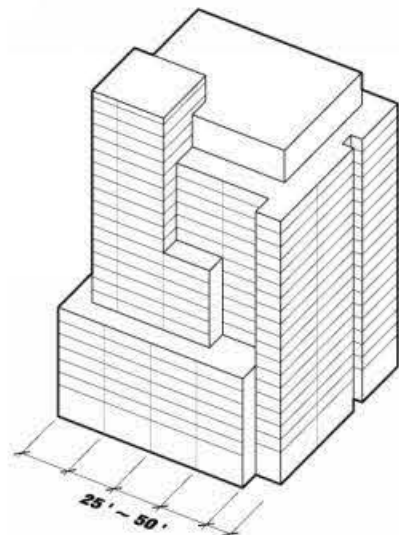

a. Bay widths of 25 to 50 feet for commercial and institutional uses

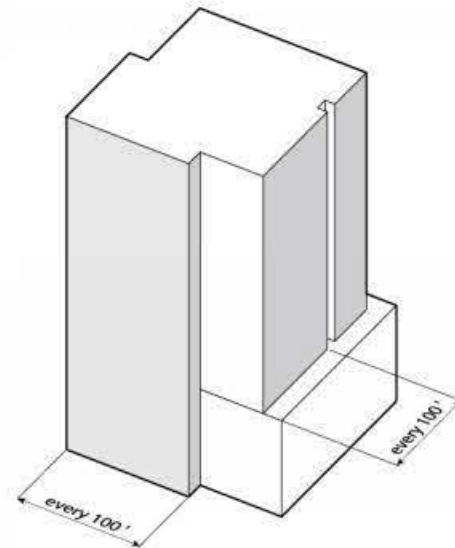

b. Example of a vertical break

Kendall Square Design Guideline
Pickard Chilton Design

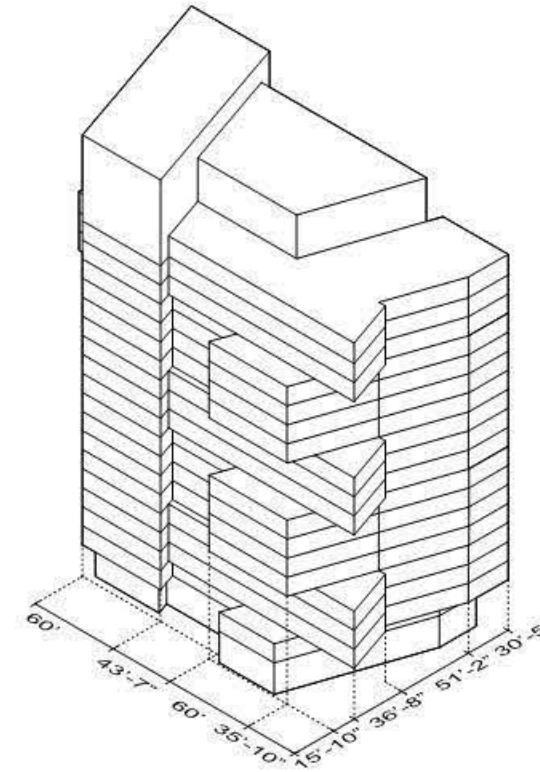

a. Massing reflects a rhythm and variation that is appropriate to the urban context. Bays widths are organized on a nominal 30' module.

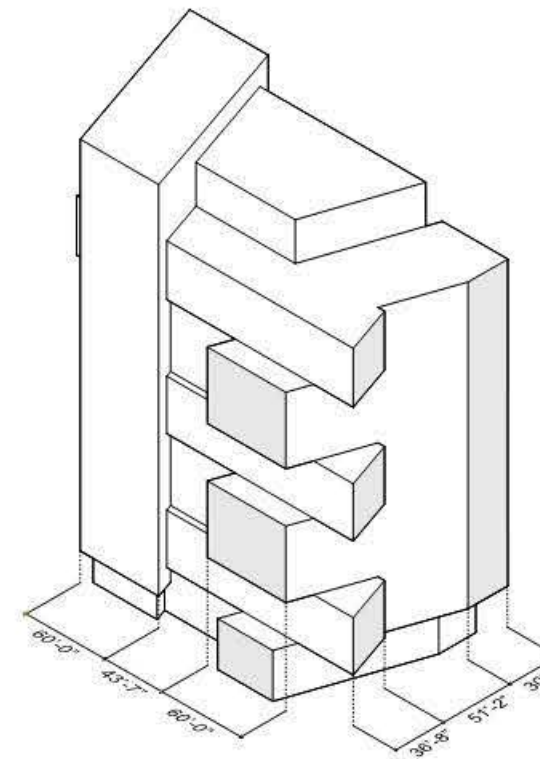
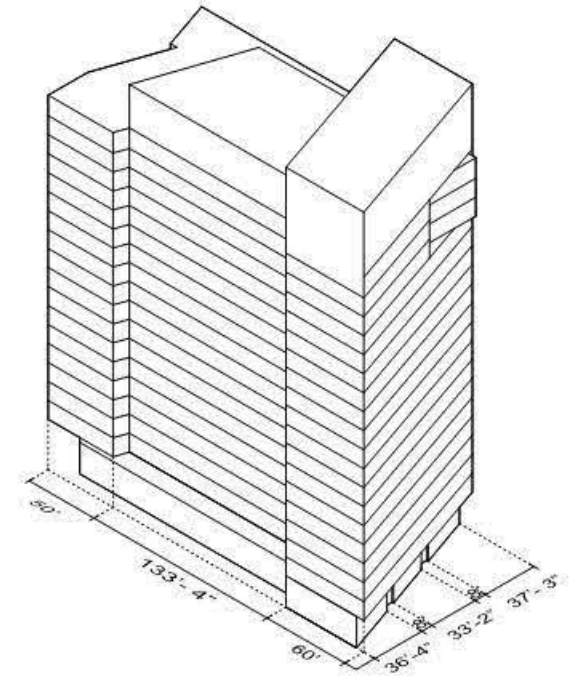

b. Vertical breaks help to define the massing and break it up into distinct massing elements.

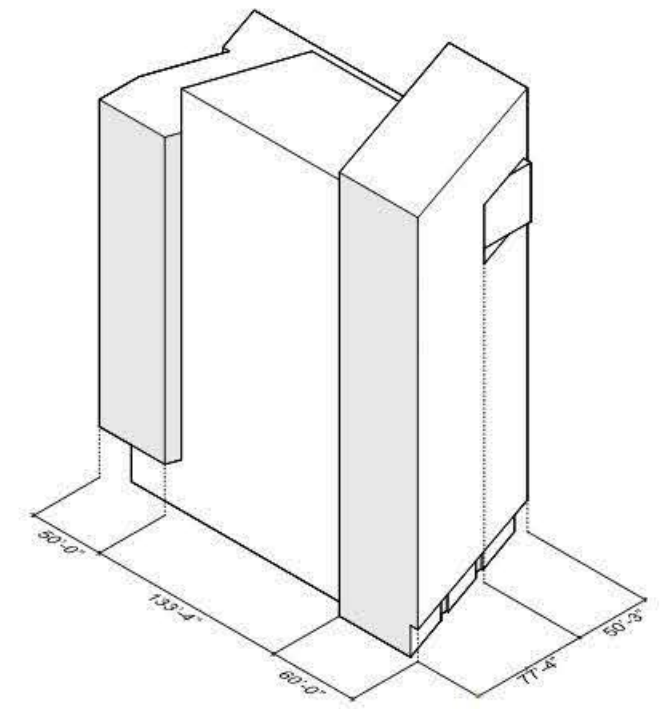

5.1.4 BUILT FORM

VISUAL INTEREST

d. Visual Interest

Goal: Where appropriate, vary the architecture of individual buildings to create architecturally diverse districts.

Measures:

- a. Use **variations in height and architectural elements** such as parapets, cornices, passive shading devices, illumination and other details to create interesting and varied rooflines.
- b. Avoid flat façades and create visual interest.
 - **Articulate bays and balconies.**
 - Utilize architectural articulation such as **changes in material, fenestration, architectural detailing, or other elements** to break down the scale.
- c. Where buildings are set back at upper stories, use lower roofs as **green roofs, balconies, terraces, and gardens.**

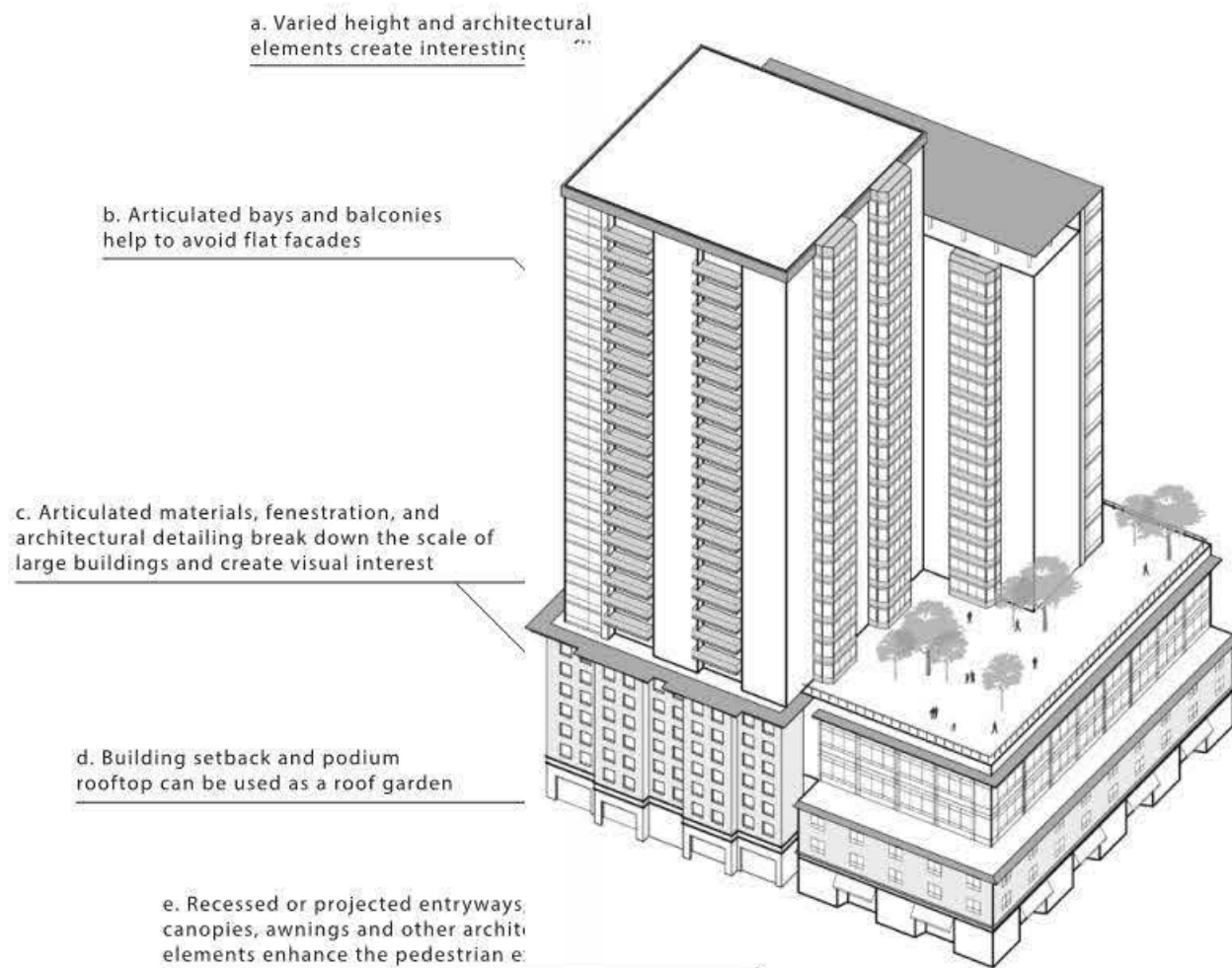

Kendall Square Design Guideline
Pickard Chilton Design

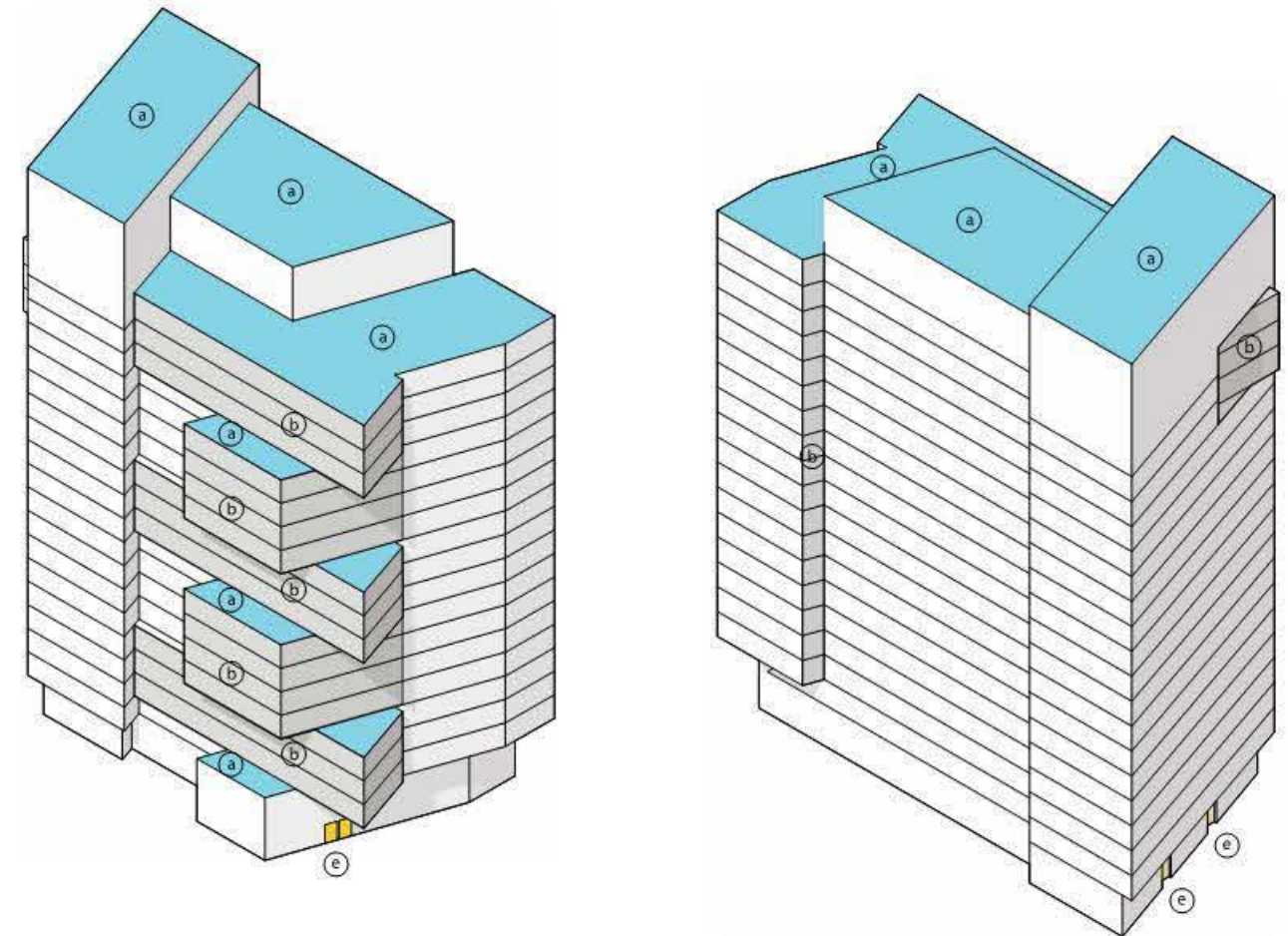

- a. Varied height and architectural elements create interesting and varied roof lines.
- b. Articulated bays and balconies help avoid flat façades.
- e. Recessed or projected entryways, canopies, awnings and other architectural elements enhance the pedestrian entrance.

5.1.5 BUILT FORM

TALL BUILDINGS

Tall Buildings

Goal: Buildings over 200 feet tall should be designed with particular attention to the architectural character of the top of the building, which will be visible from significant public spaces and from some distance. Tall buildings could potentially enhance the identity of Kendall Square by defining edges or serving as landmarks.

Measures:

- a. During design, consider the variety of vantage points from which tall buildings may be seen, especially from significant public spaces and nearby low-scale residential neighborhoods.
- b. Tall buildings should be articulated to avoid a monolithic appearance, and should emphasize slender, vertically-oriented proportions.
 - b.1 Emphasize corners using taller elements such as towers, turrets, and bays.
 - b.2 Consider the use of at least two distinct finish materials and colors on each building.
 - b.3 Consider variation in forms that present different profiles to different vantage points, if appropriate.
- c. Avoid broad “slab” volumes that make the building appear bulky. Point towers expressing vertical volumes are encouraged.
- d. Consider legibility of the building top both by day and night, while demonstrating responsible use of lighting and energy consistent with sustainability requirements.

Kendall Square Design Guideline
Pickard Chilton Design

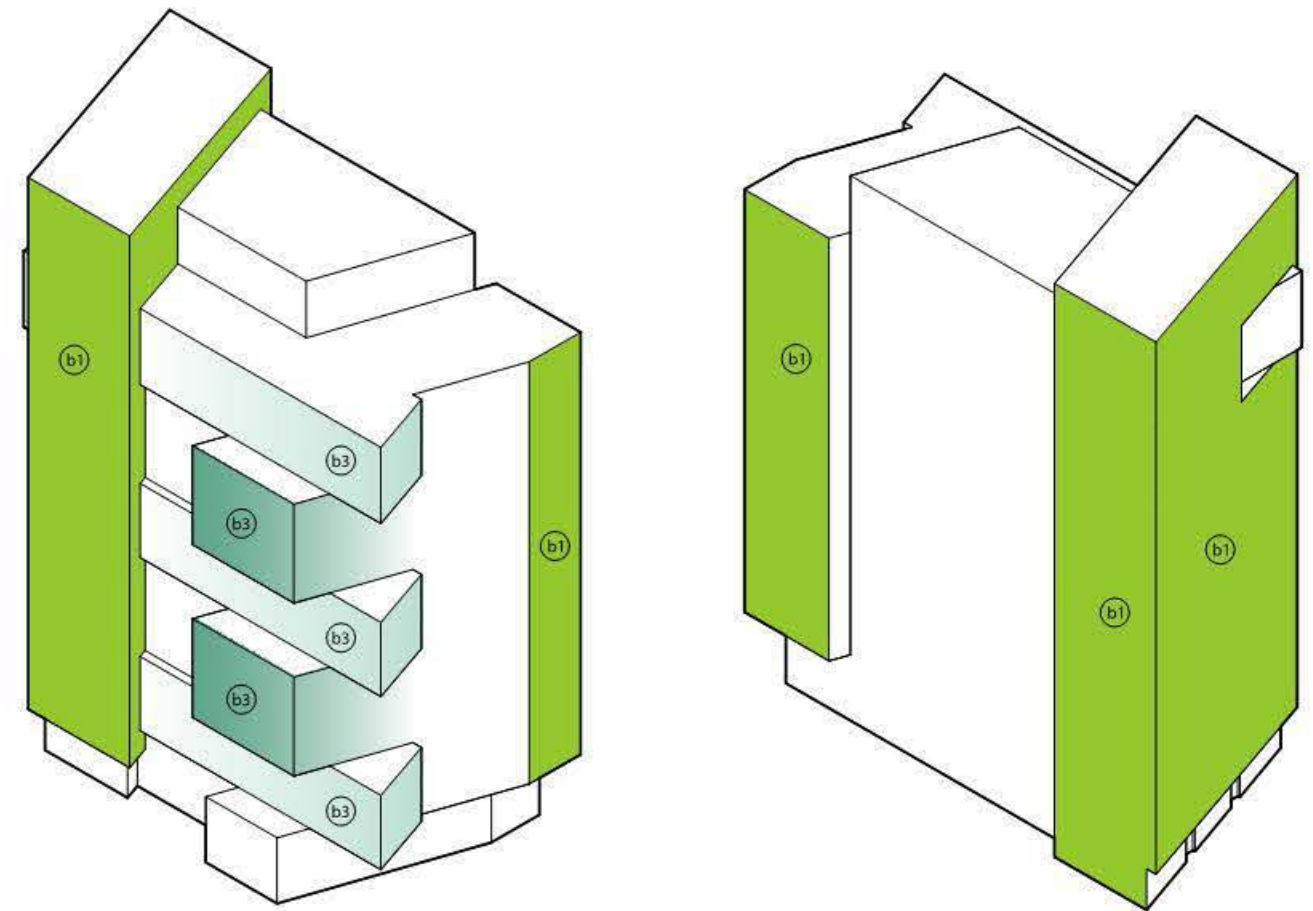

- b. 1 Emphasize corners using taller elements such as towers, turret, and bays.
- b. 3 Variation in forms present different profiles to different vantage points.

5.1.6 BUILT FORM

ROOFTOPS

Rooftops

Goal: The design of rooftops, including mechanical equipment and cellular installations, should be conceived as integral to the rest of the architecture of the building.

Measures:

- Rooftop mechanicals may be designed to stand out as machinery, in which case it needs to be carefully arranged to give a pleasing visual image.
- Screening may be used to conceal rooftop mechanicals, and in this case, the screening should be in the same idiom as the rest of the architecture.
- It may be possible to use both techniques listed above.
- To the extent possible, provisions should be made so that future cellular installations may be placed upon the building without detriment to the architecture, e.g. a blank wall of a mechanical screen may be conceived as such a location.

Kendall Square Design Guideline
Pickard Chilton Design

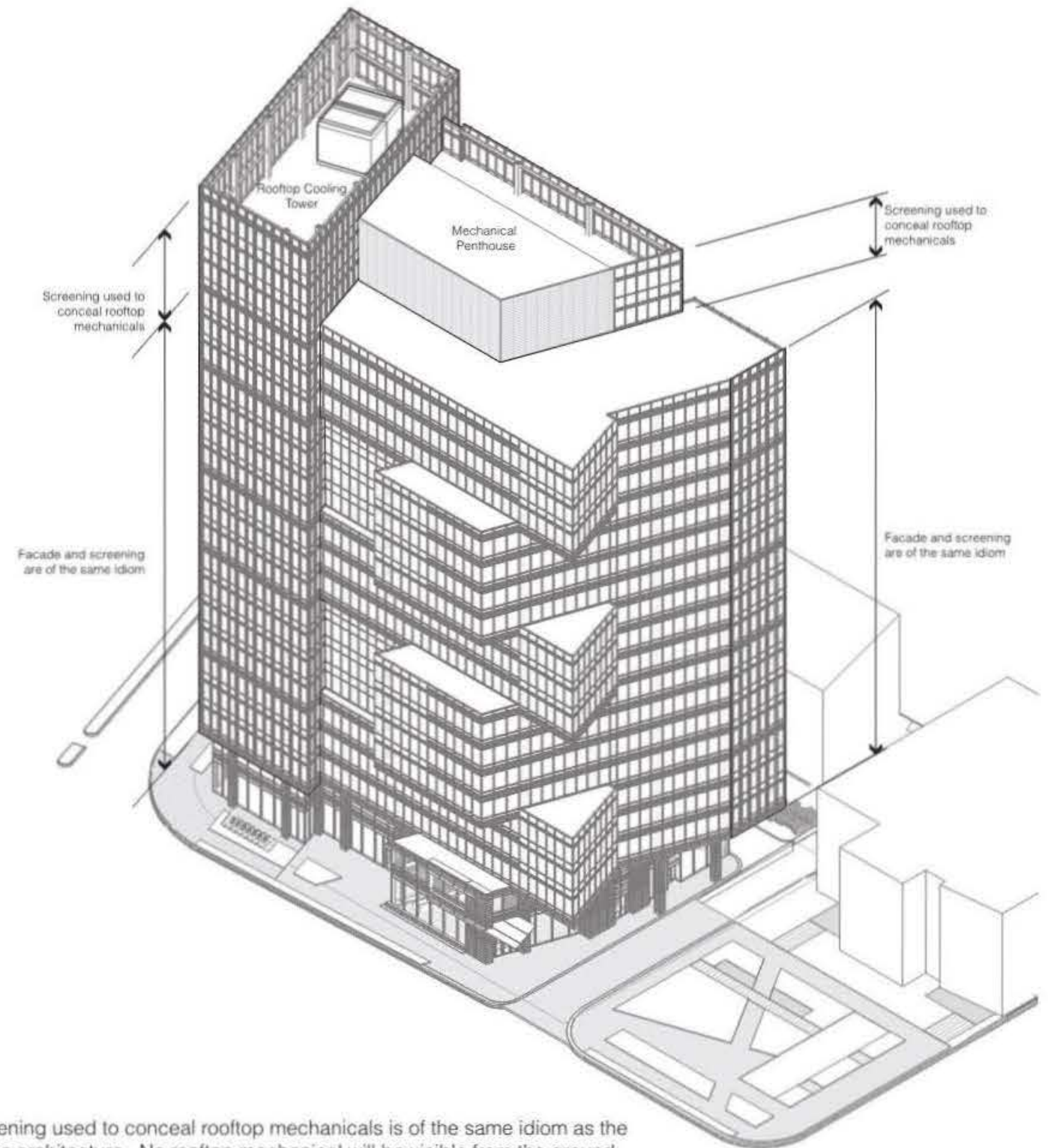

1. Screening used to conceal rooftop mechanicals is of the same idiom as the rest of the architecture. No rooftop mechanical will be visible from the ground level and will be screened from view.

5.2.1 GROUND FLOOR

RETAIL OR MIXED-USE GROUND FLOORS

Ground Floor Design Guidelines

a. Retail or Mixed-use Ground Floors

– Uses

Goal: First floors of the buildings should be actively used.

Measures:

- Along Major Public Streets** - Approximately 75 percent of the street frontage should be occupied by retail uses such as cafes, restaurants and shops.
- Along Secondary Streets** - Approximately 75 percent of the street frontage should be occupied by active uses. Active uses include:
 - retail (i.e. cafes, restaurants, shops)
 - educational and cultural venues
 - services for the public or for commercial offices (fitness centers, cafeterias open to the public, daycare centers, etc.)
 - community spaces (exhibition or meeting space)
 - art/information exhibition windows; live/work spaces
- Lobbies for office, research and residential uses are discouraged from occupying extensive ground floor frontage.
- Carefully designed residential stoops and entries that meet ADA requirements are encouraged.

Goal: Retail and services should serve local communities as well as people who work in the area.

Measures:

- Leasing of space to small, locally-owned businesses is encouraged.
- Diverse retail and service offerings that serve current and future Kendall Square residents and surrounding neighborhoods (e.g. pharmacy, greengrocer, bakery, drycleaner, and convenience store) are encouraged.
- Building frontage devoted to bank, trust company or similar financial institution should be limited to approximately 25 feet. Larger floor areas can be devoted to bank uses when fronted with other active retail uses.

Goal: Where retail is not provided, ground floor spaces should be designed to accommodate retail in the future.

Measures:

Standards for spaces convertible to retail include:

- Adequate floor-to-floor height (e.g. 15-20 feet) to allow food-oriented uses, with ventilation etc.
- Leasable ground floor depth from façade should average about 40 feet
- Ground floor level flush with or easily accessible from sidewalk
- Ground floor façade readily convertible to retail-style storefront
- Designed to accommodate venting and exhaust needs of food service uses
- Services such as interior power and HVAC zoned or easily convertible to enable convenient division and sublease of interior spaces to retail tenants.

Kendall Square Design Guideline
Pickard Chilton Design

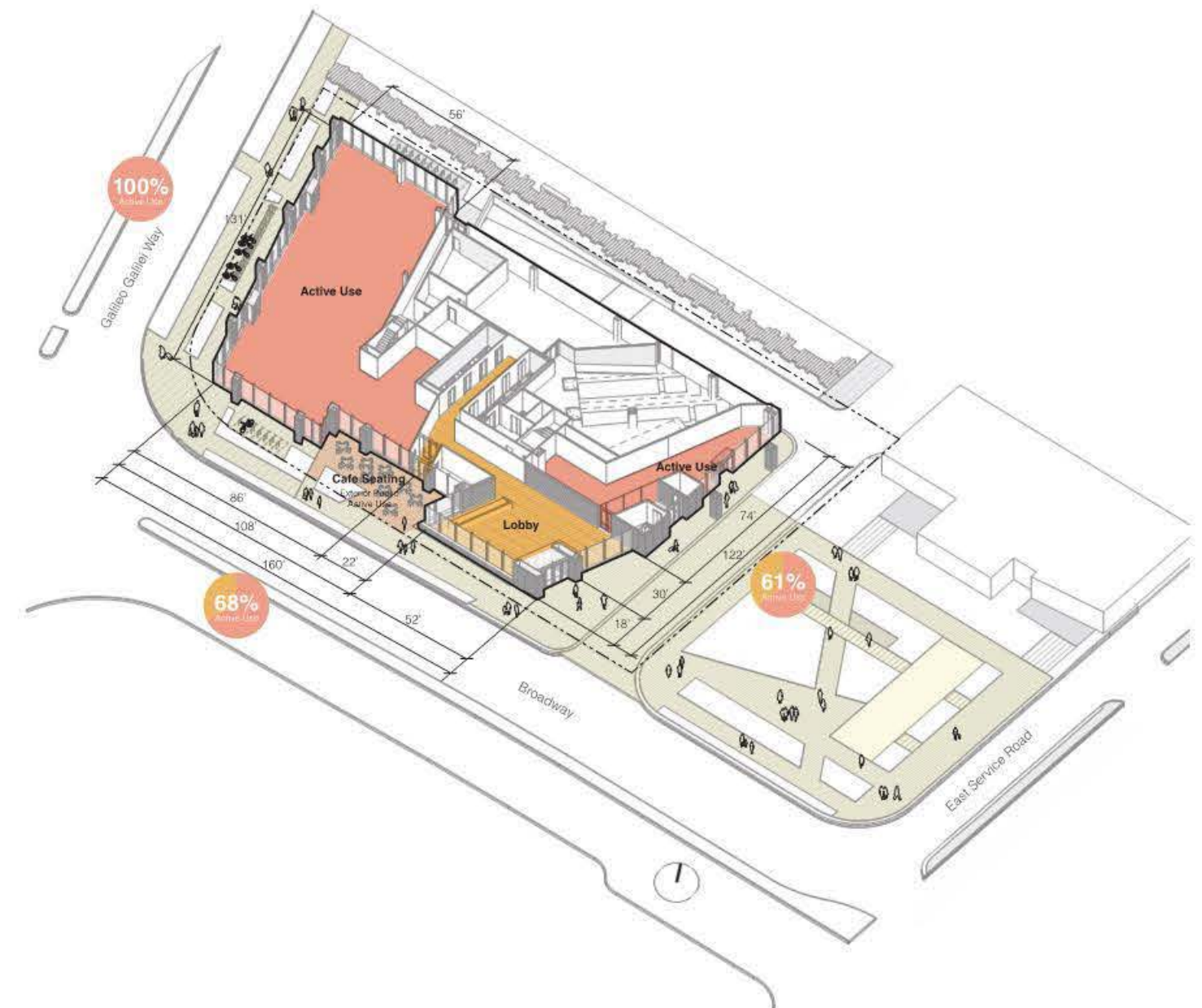

- 145 Broadway provides an active ground level with the majority of frontage along Broadway occupied by Active Use space and Active Public Gathering Space. 145 Broadway Lobby occupies minimal frontage along Broadway.
- 100% of the frontage along Galileo Way is occupied by Active Use space.

5.2.2 GROUND FLOOR

SETBACKS

– Setbacks

Goal: Create space at the sidewalk level to allow for interaction between activities on the ground floor of the buildings and the public sidewalk.

Measures:

- Ensure that the sidewalk includes ample space for walking, street furniture, street trees, bicycle parking and other plantings, and is designed to accommodate a high level of access for all users, including those in wheelchairs or pushing strollers.
- Provide a small setback (5 to 15 feet) from the right-of-way for café seating, benches or small open spaces.

Goal: Buildings should be directly engaging to the public and create a well-defined streetwall to help frame Kendall Square's streets and public spaces.

Measures:

- Setbacks exceeding 10 feet should be provided with caution.
- Setbacks used exclusively for ornamental landscaping are not encouraged.

Kendall Square Design Guideline
Pickard Chilton Design

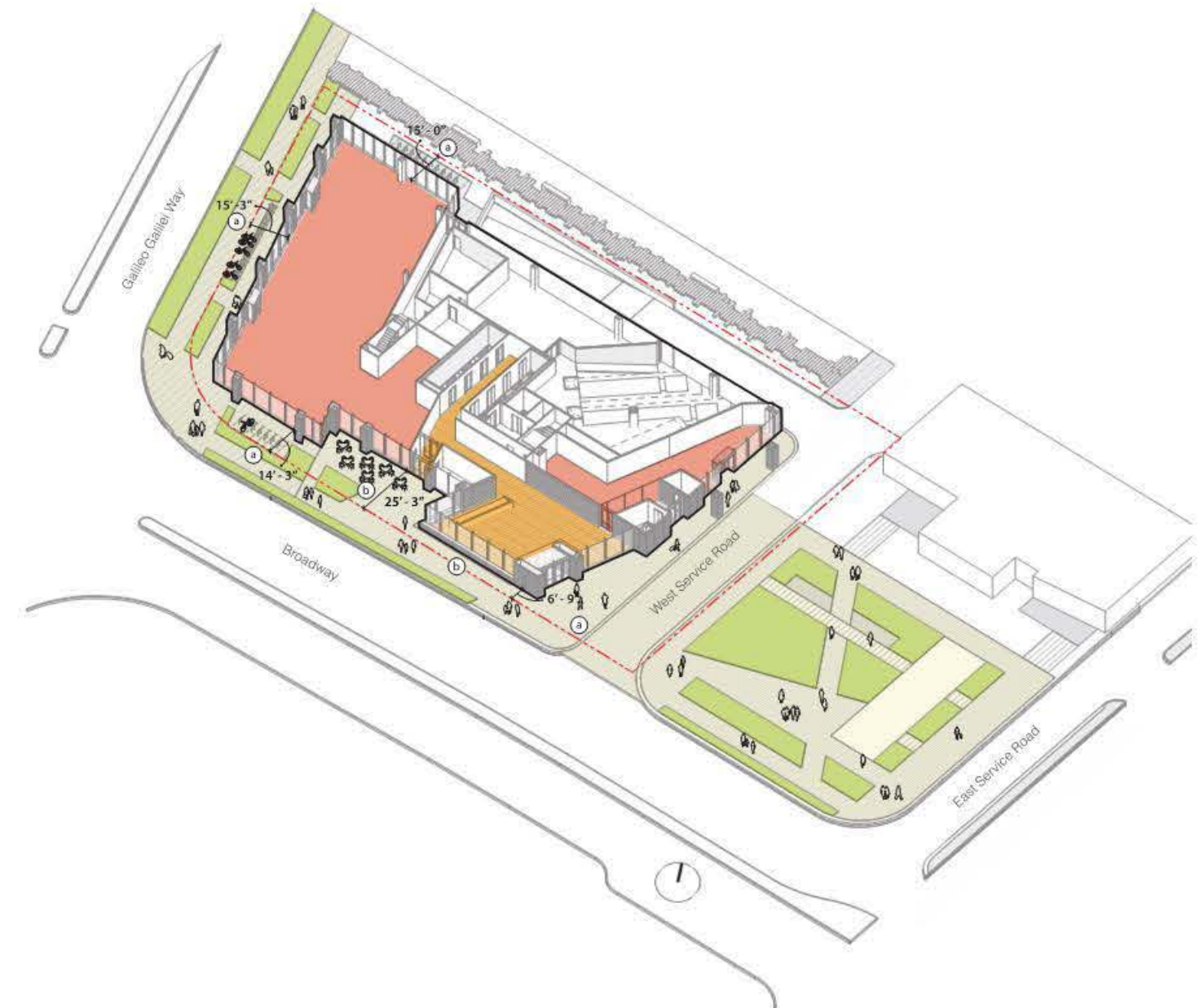

a. Sidewalk includes ample space and is designed to accommodate a high level of access for all users, including those in wheelchairs or pushing strollers.

b. Architecture provides a small setback from the right-of-way for cafe seating, benches and small open spaces.

5.2.3 GROUND FLOOR

FACADES

– Façades

Goal: Design ground floor façades of building to reduce the distinction between exterior and interior space to extend the effective public realm indoors and reveal indoor activity on the street.

Measures:

- Transparent materials and interior lighting should be used to maximize visibility of street level uses. Transparency is most important in the portion of the facade between about 2 feet to about 10 feet above the sidewalk level, i.e. where people are likely to look in. Incorporate 60 to 75 percent transparent glazing in the ground level façade along major public streets and 40 to 60 percent transparent glazing in the ground level façade along secondary streets.
- Active ground level spaces should have strong, interactive connections with adjacent public sidewalk/plaza space using strategies such as extensive transparent glazing, interactive media or public art, large operable doors and windows, or associated outdoor seating.
- Blank walls exceeding 20 feet in length should be avoided.
- Awnings and canopies are encouraged to provide shelter and enliven ground floor facade.
- Mechanical/utility rooms and service/loading areas are not appropriate along the major streets and should be located on secondary streets.

Kendall Square Design Guideline
Pickard Chilton Design

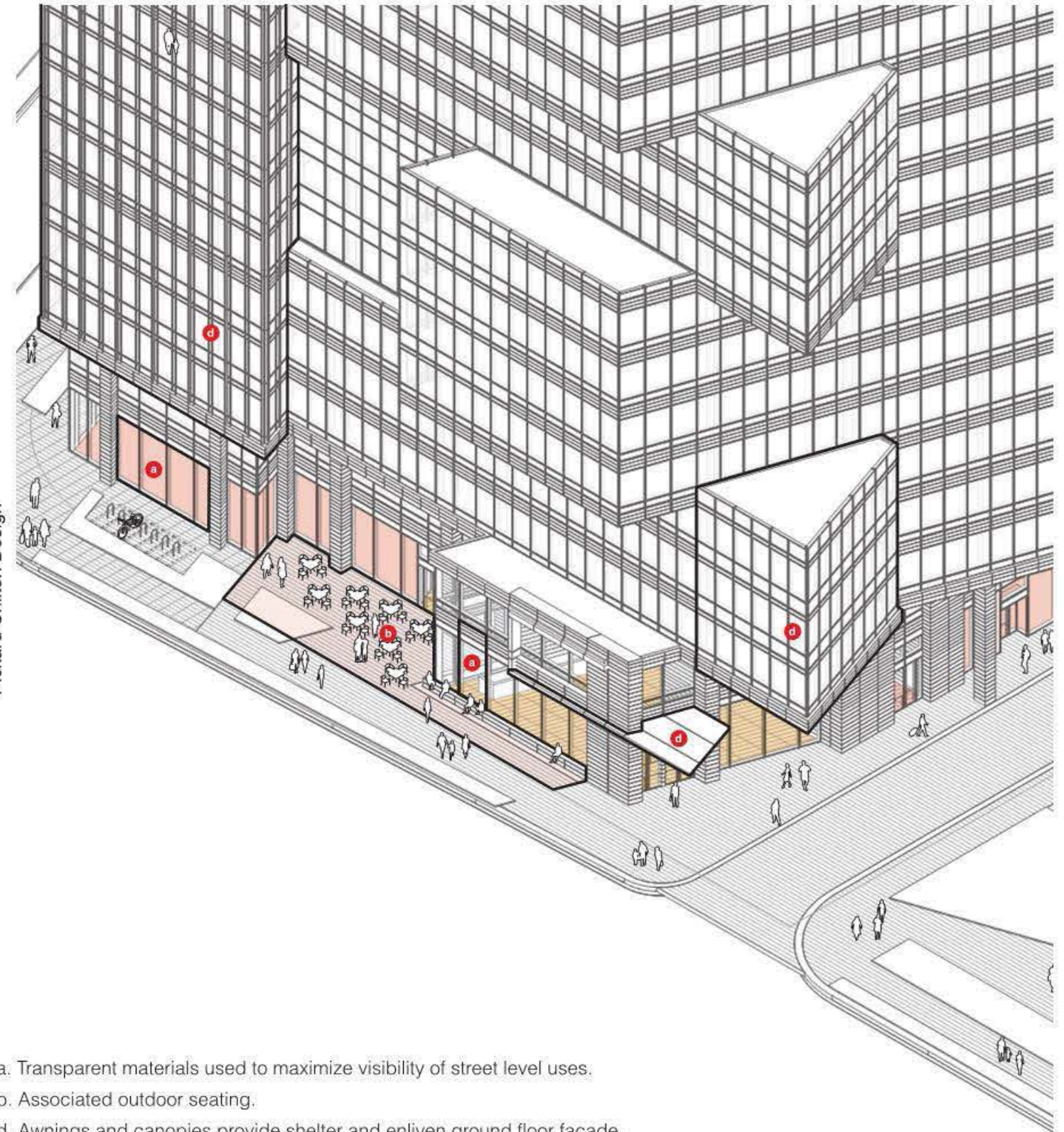

- Transparent materials used to maximize visibility of street level uses.
- Associated outdoor seating.
- Blank walls exceeding 20 feet in length should be avoided.
- Awnings and canopies provide shelter and enliven ground floor facade.

5.2.4 GROUND FLOOR

ENTRANCES

- Entrances

Goal: Major entrances should be located on public streets, and on corners wherever possible. If appropriate, entrances should relate to crosswalks and pathways that lead to bus stops, transit and bike stations.



Kendall Square Design Guideline
Pickard Chilton Design



