

BLUE GARAGE

CRA DESIGN REVIEW MEETING

November 4, 2020



PICKARD CHILTON

Meeting Agenda

- 1 Planning & Massing Components**
- 2 Substation Location Diagram**
- 3 Day-Lit Open Space**
- 4 Vision/Opportunity**
- 5 Sense of Place**
- 6 Discussion**







VISION: Create a Wonderful Place Where



The Community can Flourish



All Feel Welcome and Included

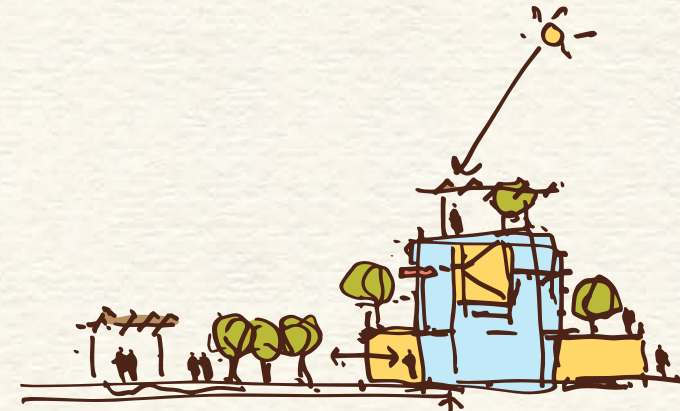

Sustainability, Resiliency, and Wellness Inform the Design

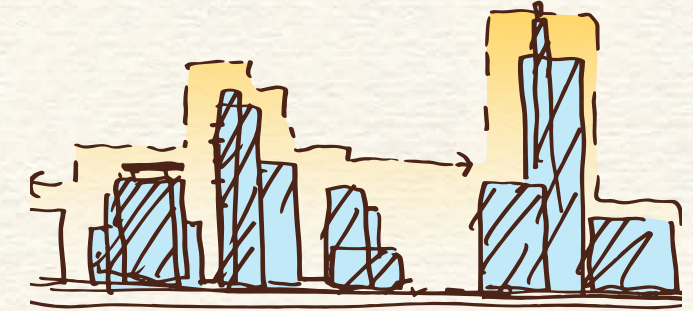

Diverse Urban Forms Create a Varied and Beautiful City Scape

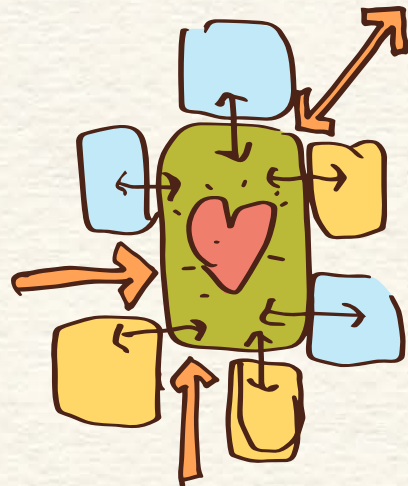

A Vibrant Central Space Connects to the Network of Cambridge Open Spaces



The Design Enriches and Activates the Public Realm



People, Bikes, and Cars Share the Urban Space

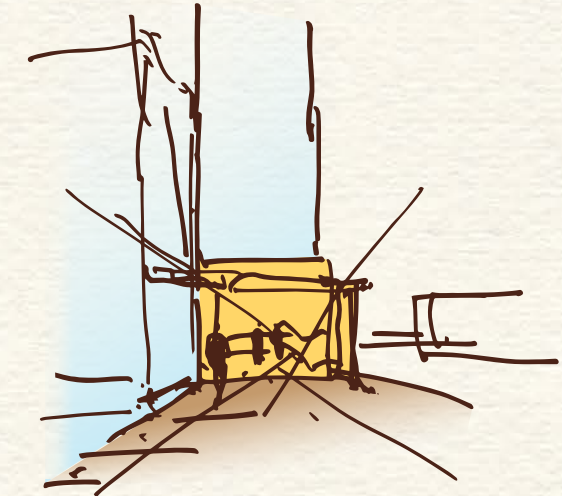

Thresholds and Framed Views Enrich the Experience

WELLINGTON
HARRINGTON
NEIGHBORHOOD

EAST CAMBRIDGE
NEIGHBORHOOD

THE PORT
NEIGHBORHOOD

NORTH PARCEL

VOLPE
DEVELOPMENT

PARCEL THREE

MITIMCo NoMa

MITIMCo SoMa

MASSACHUSETTS
INSTITUTE OF
TECHNOLOGY

CHARLES RIVER

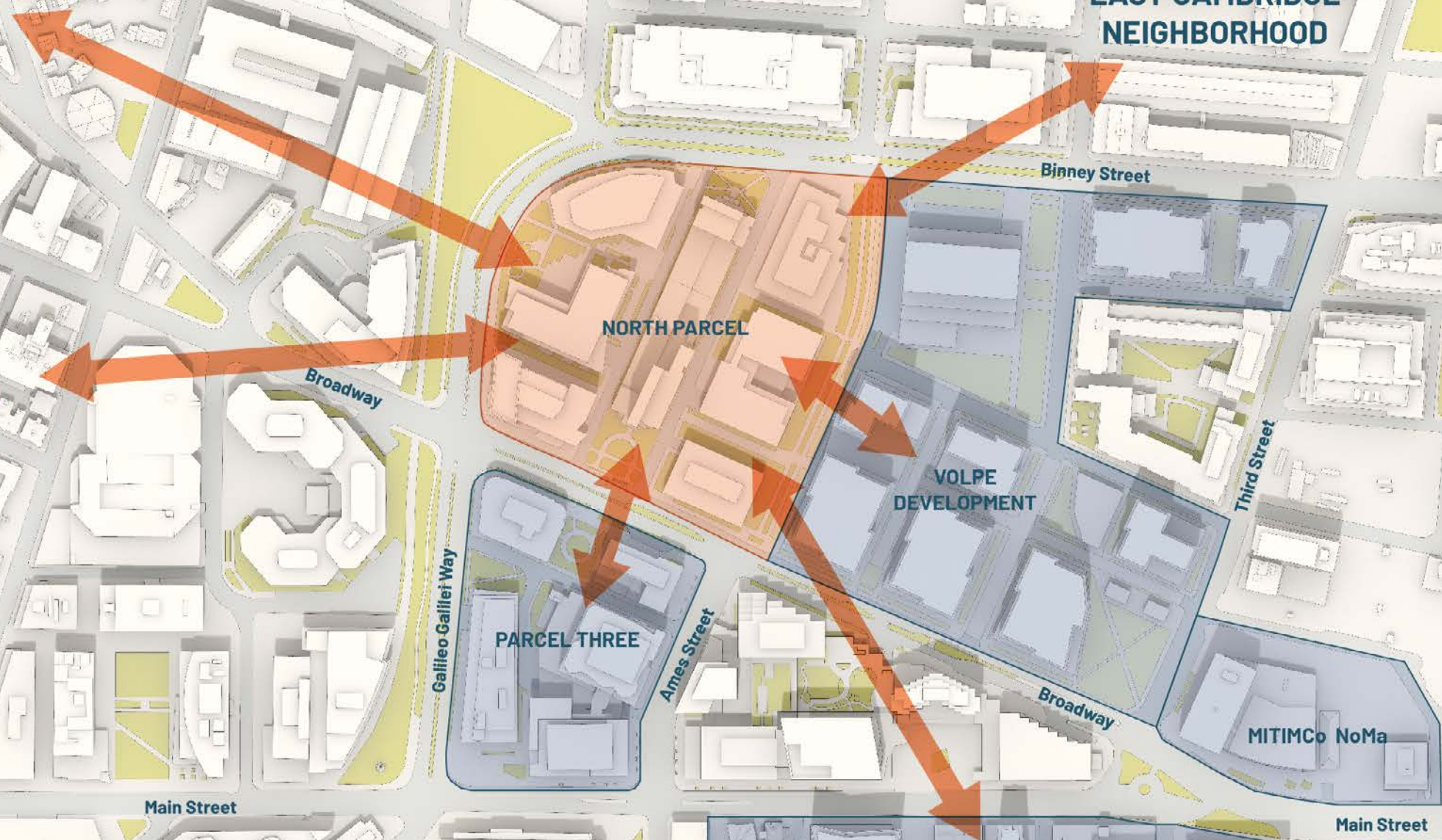



Binney Street Park

North Park

6th Street Connector

5th Street Pomenade and Volpe Art Walk

Henri A. Termeer Square

Technology Square

South Park

KS0 Rooftop Garden

3rd Street Park

Kendall Plaza

CHARLES RIVER



Binney Street Park

New Open Space

6th Street Connector

5th Street Promenade and Volpe Art Walk

Henri A. Termeer Square

Technology Square

KS0 Rooftop Garden

3rd Street Park

Kendall Plaza

CHARLES RIVER



bxp Boston Properties

PICKARD CHILTON

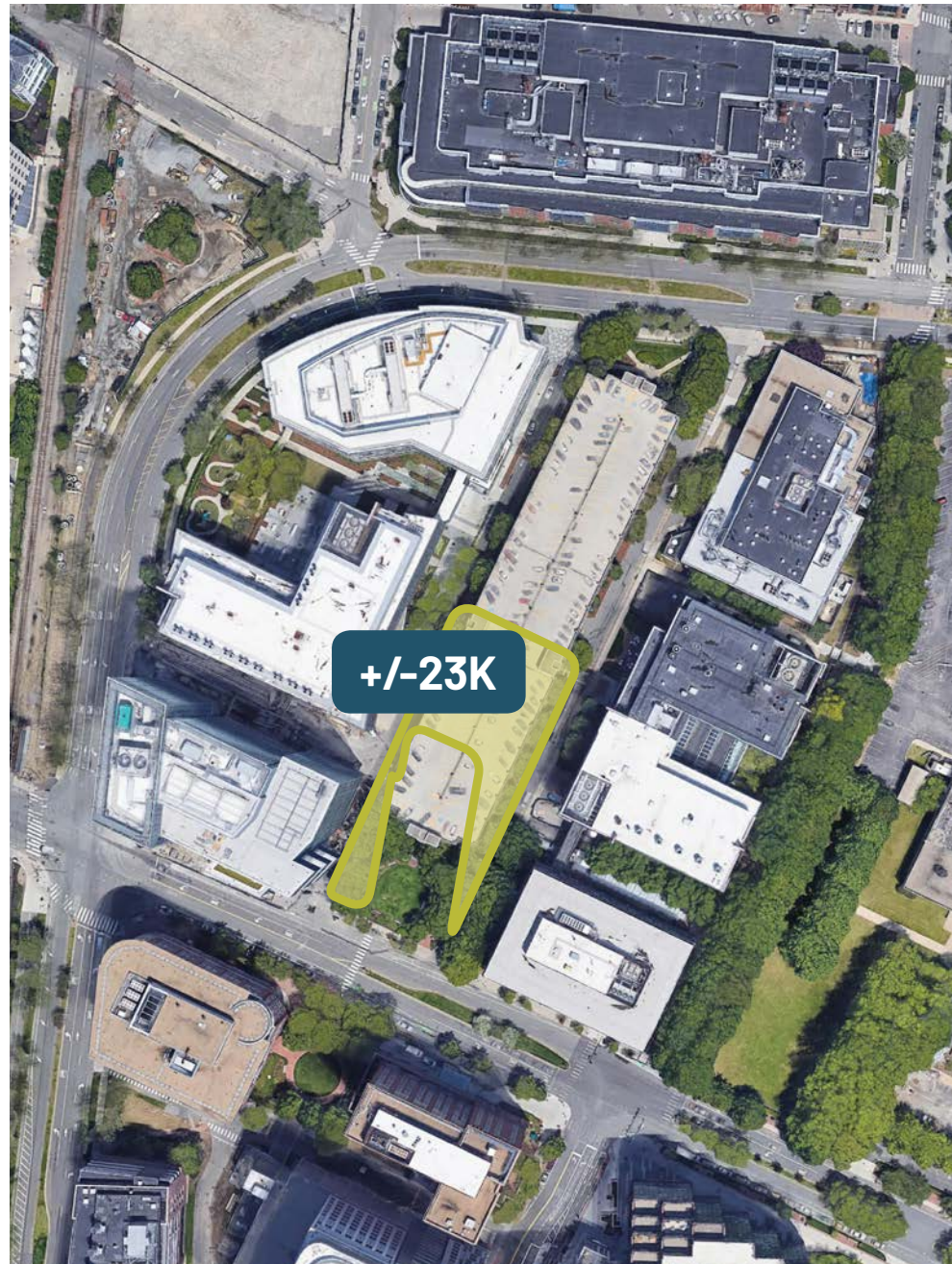

**Blue Garage
Cambridge, MA**



**Commonwealth Ave, Greenway
Boston, MA**



**Henri A. Termeer Square
Boston, MA**



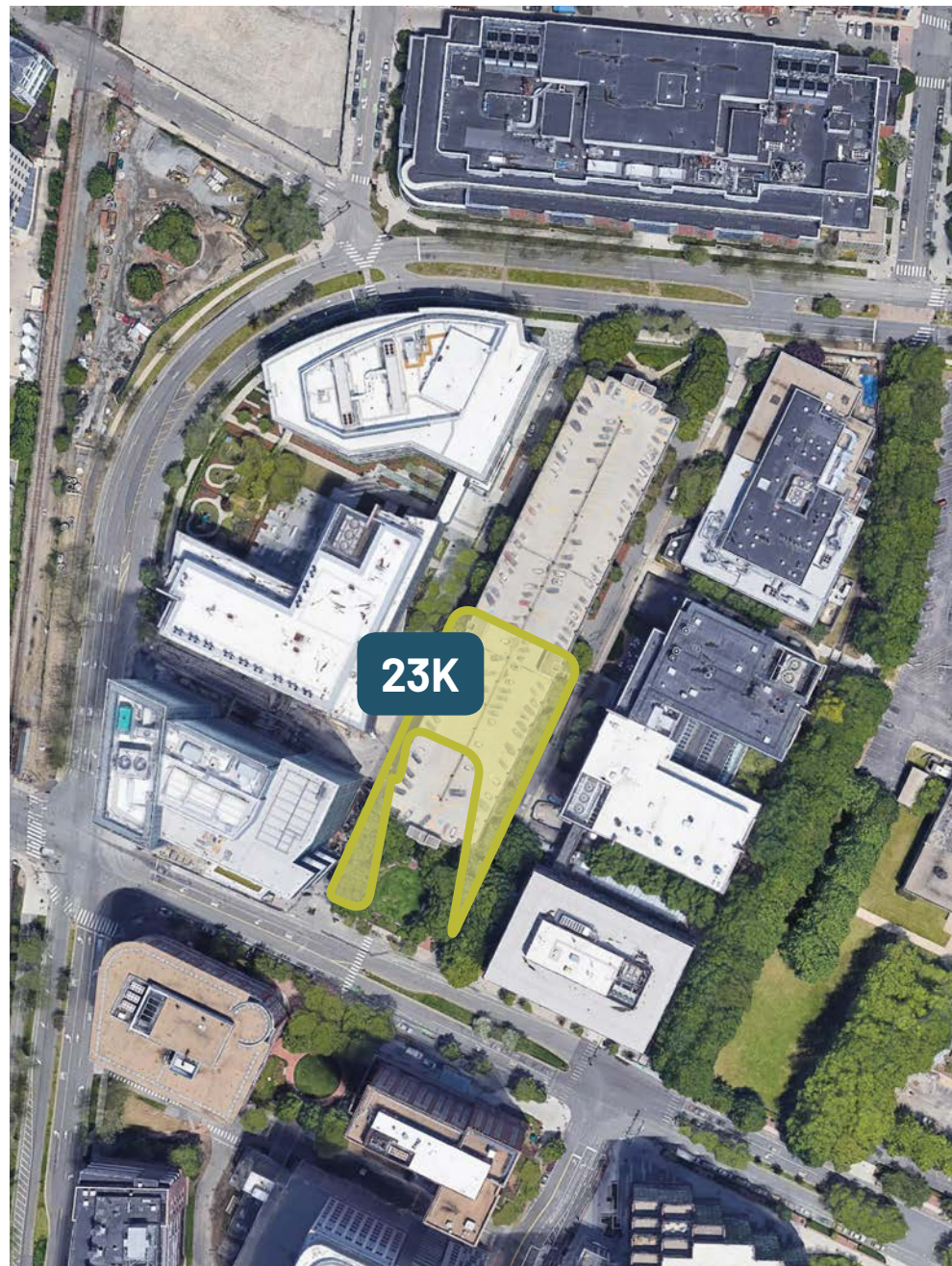

**Blue Garage
Cambridge, MA**

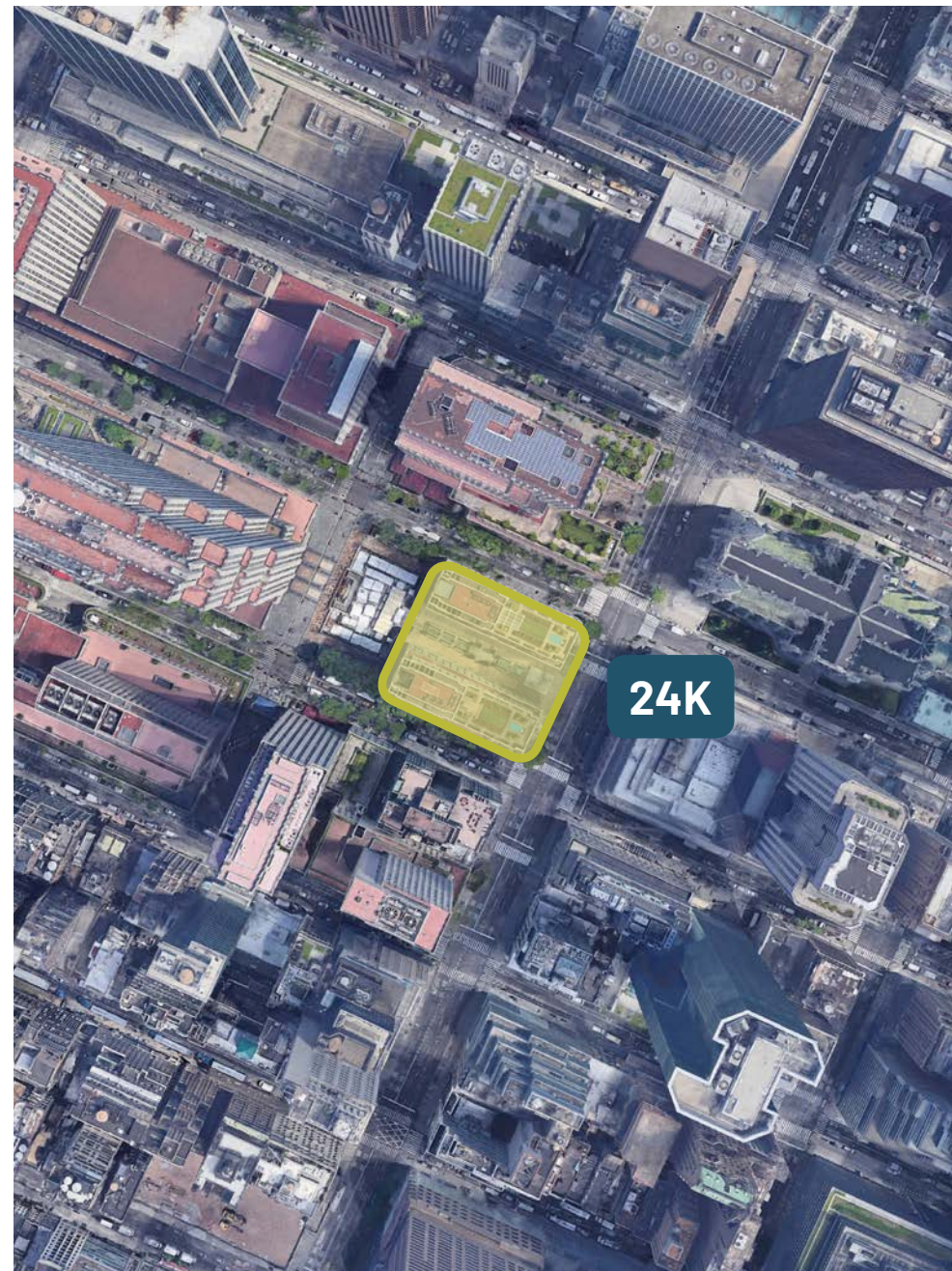

**Rockefeller Center
New York, NY**



**Front Park
Cambridge, MA**



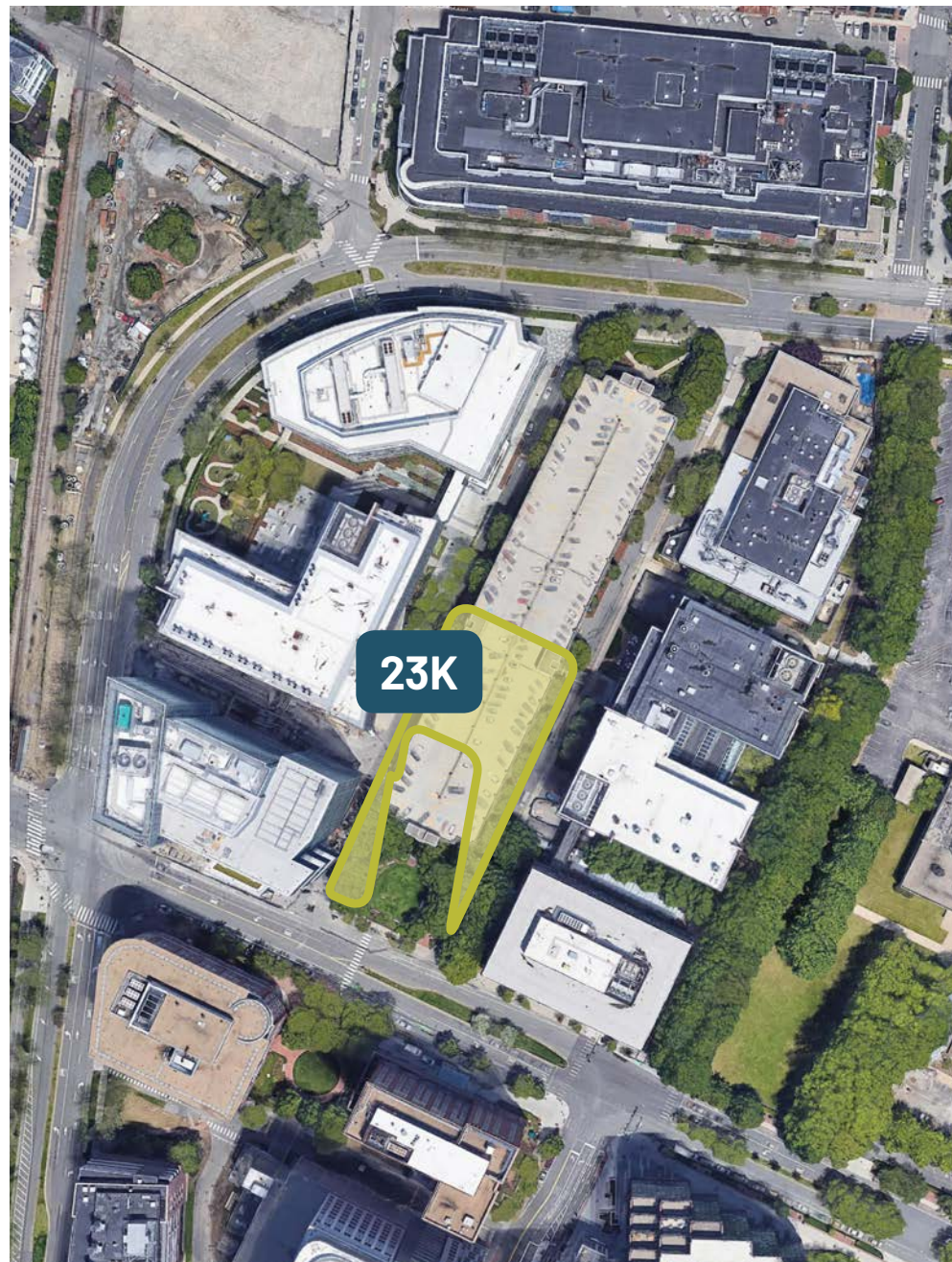

Blue Garage
Cambridge, MA



Wheeler Park
Cambridge, MA



Winthrop Square
Cambridge, MA





CHARLES RIVER

A Vibrant Central Space Connects to the Network of Cambridge Open Spaces

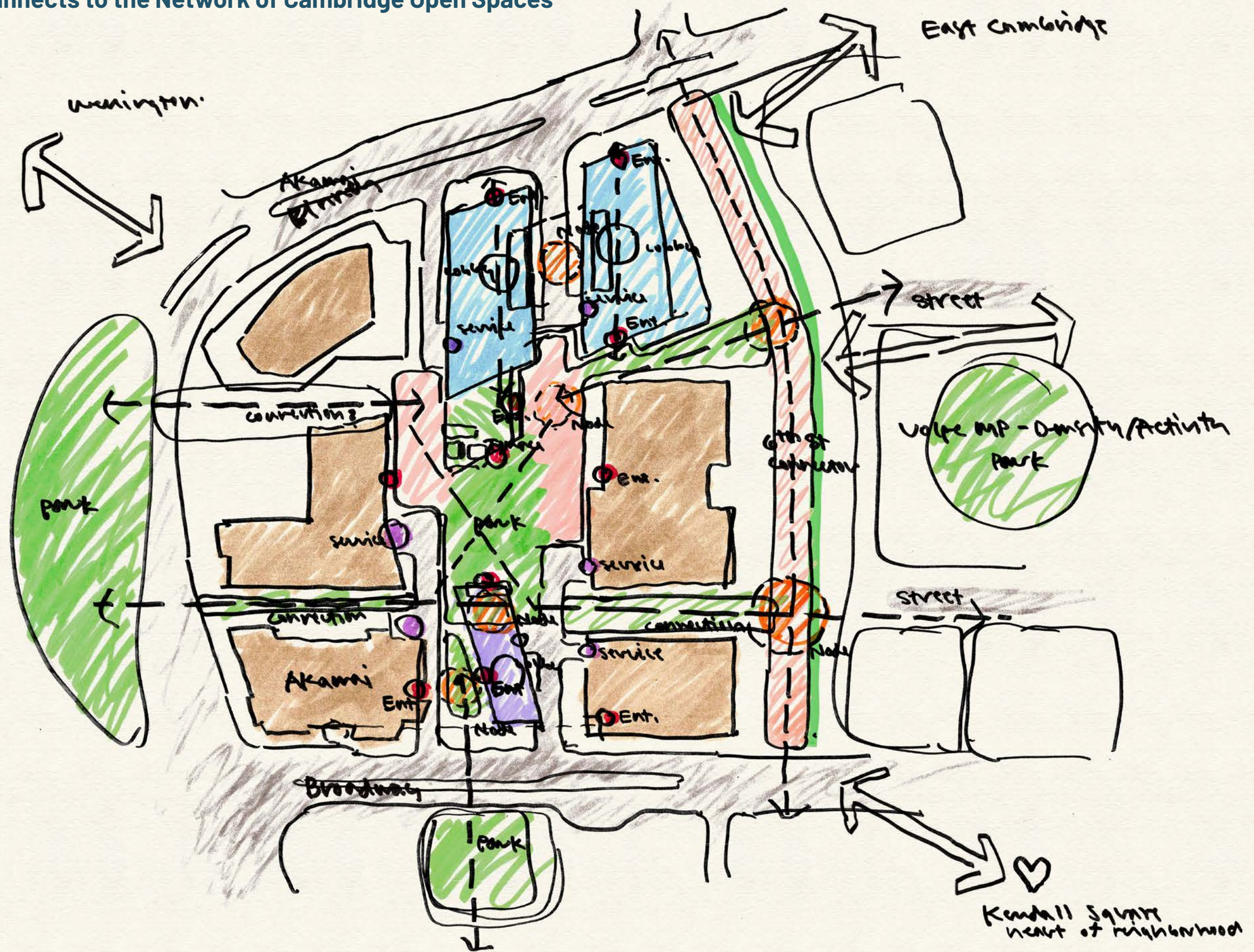

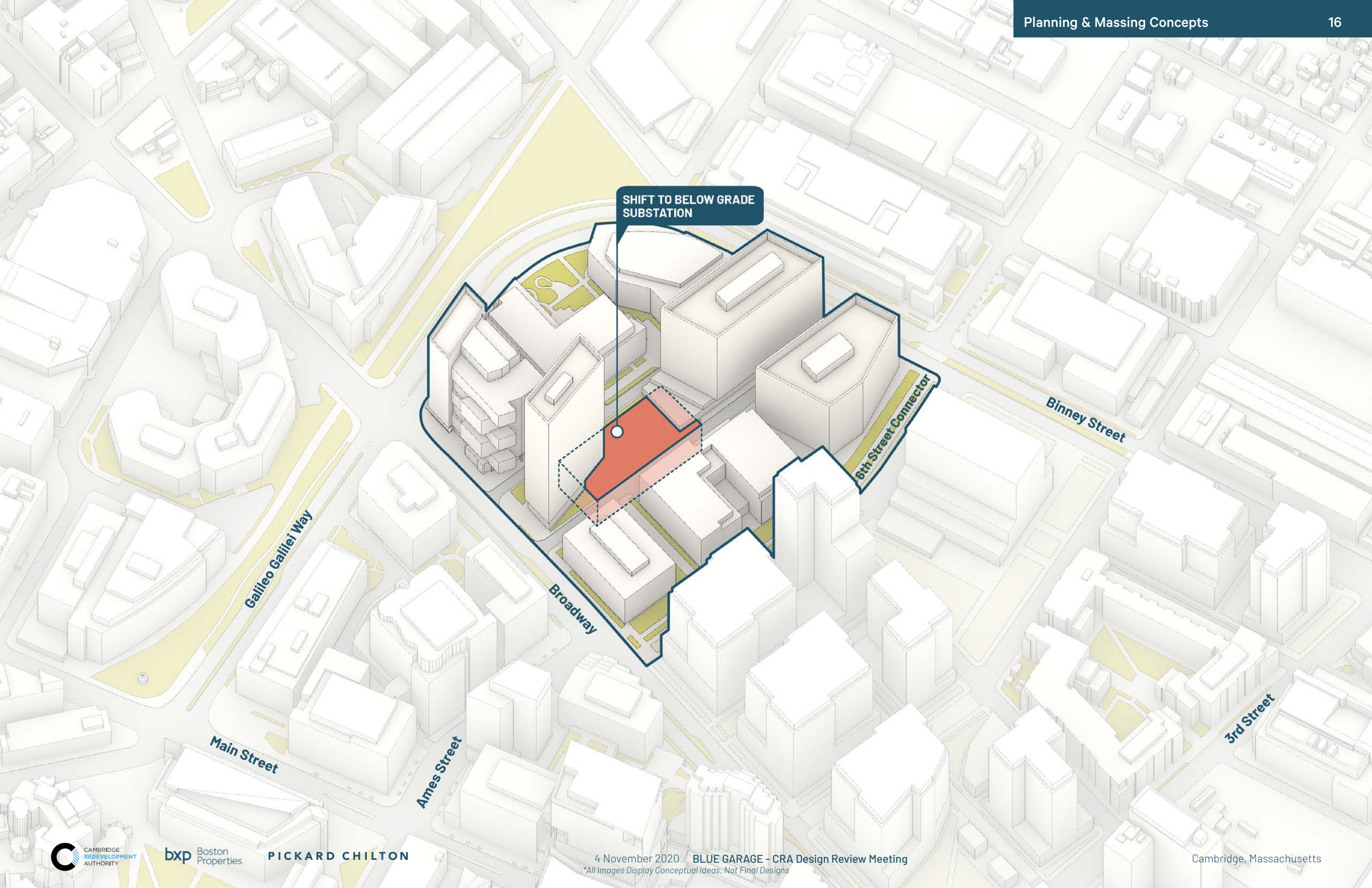

SHIFT TO BELOW GRADE
SUBSTATION

Galileo Galilei Way

Main Street

Ames Street

Broadway

6th Street Connector

Binney Street

3rd Street

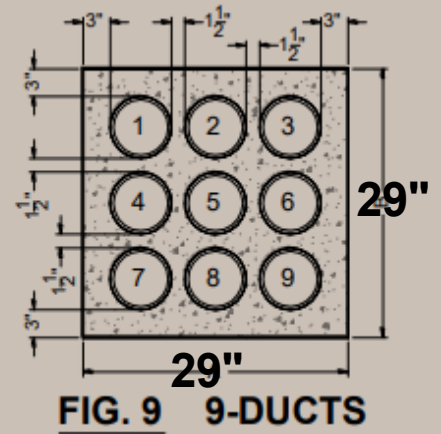
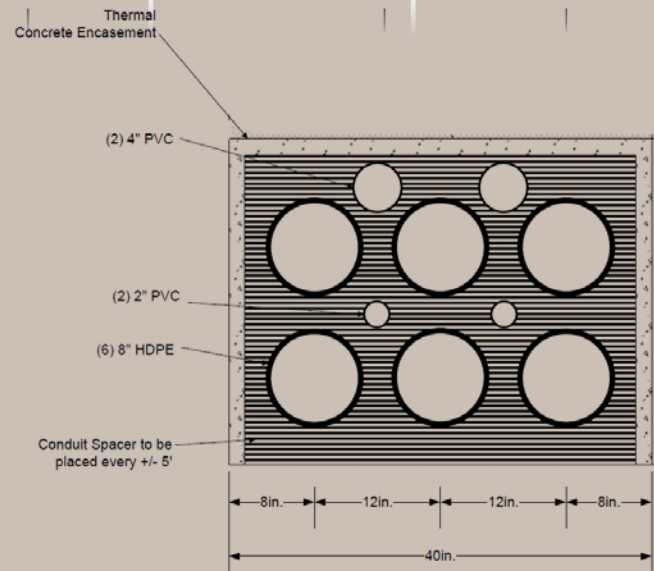
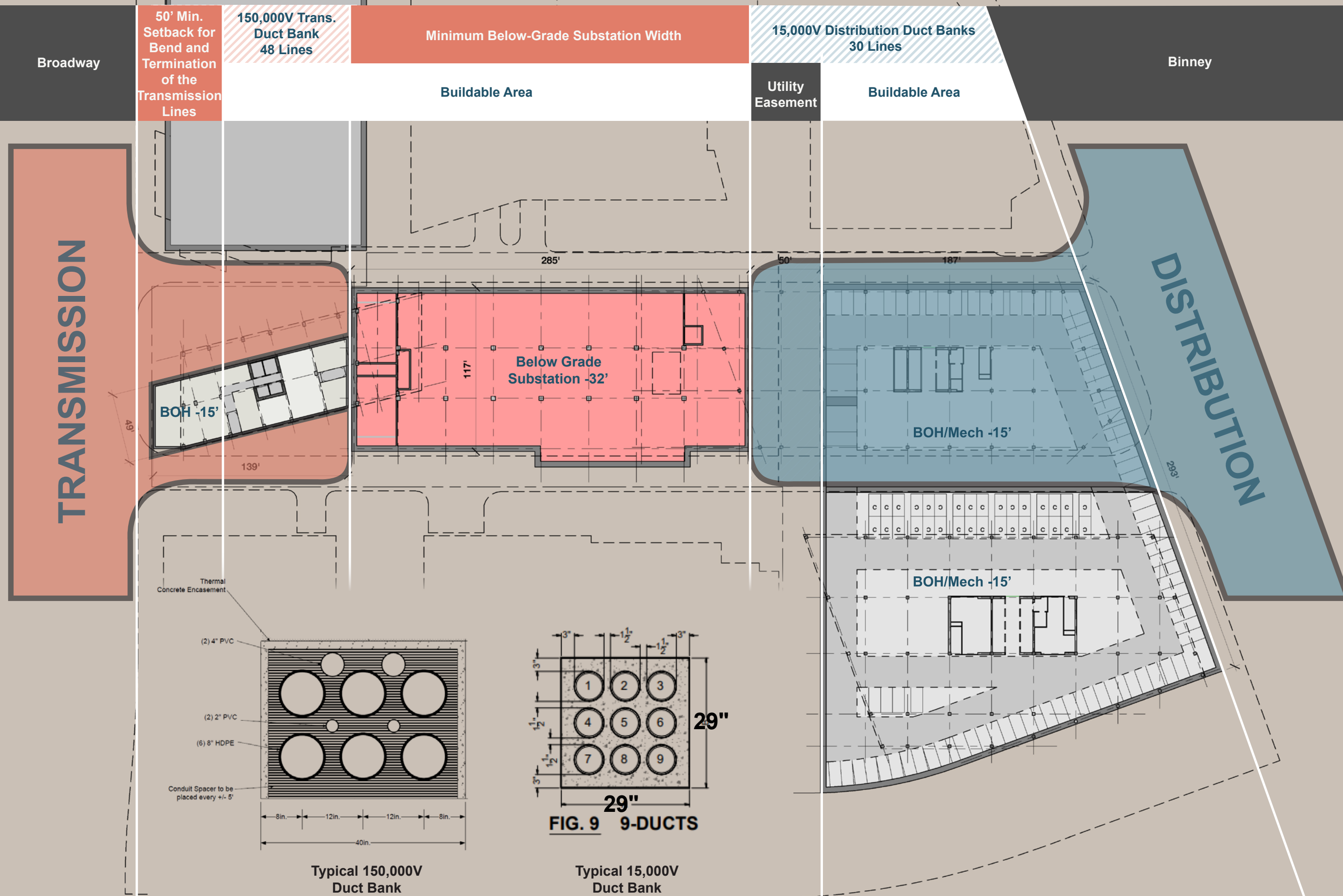
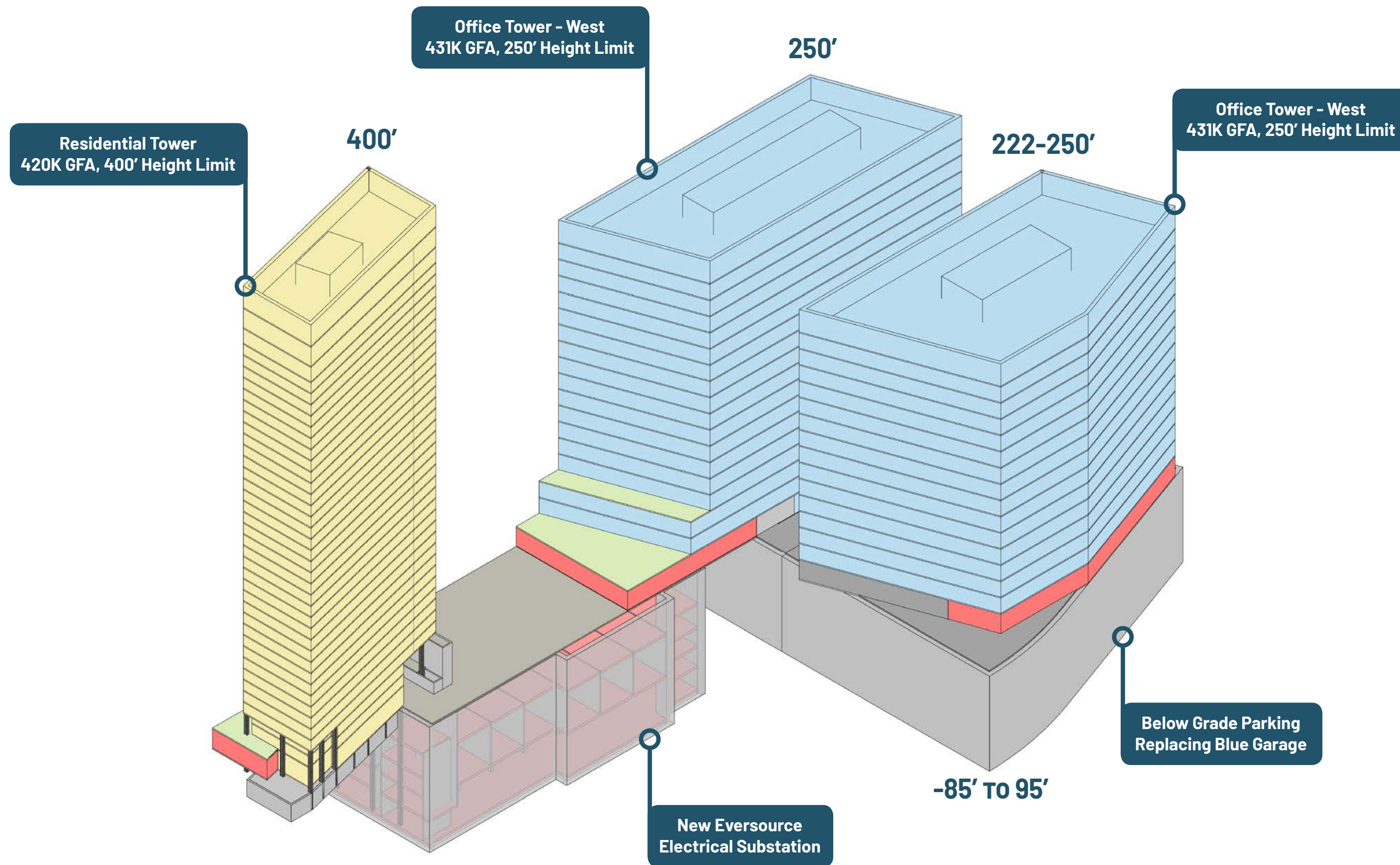

FIG. 9 9-DUCTS



TERRACES TO CREATE ACTIVITY ON SECOND LEVEL AND INCORPORATION OF EVERSOURCE ABOVE GRADE EQUIPMENT

OFFICE BUILDING - WEST PARCEL

OFFICE BUILDING - EAST PARCEL

RESIDENTIAL BUILDING

6th Street Connector

Binney Street

Galileo Galilei Way

Broadway

Main Street

Ames Street

3rd Street

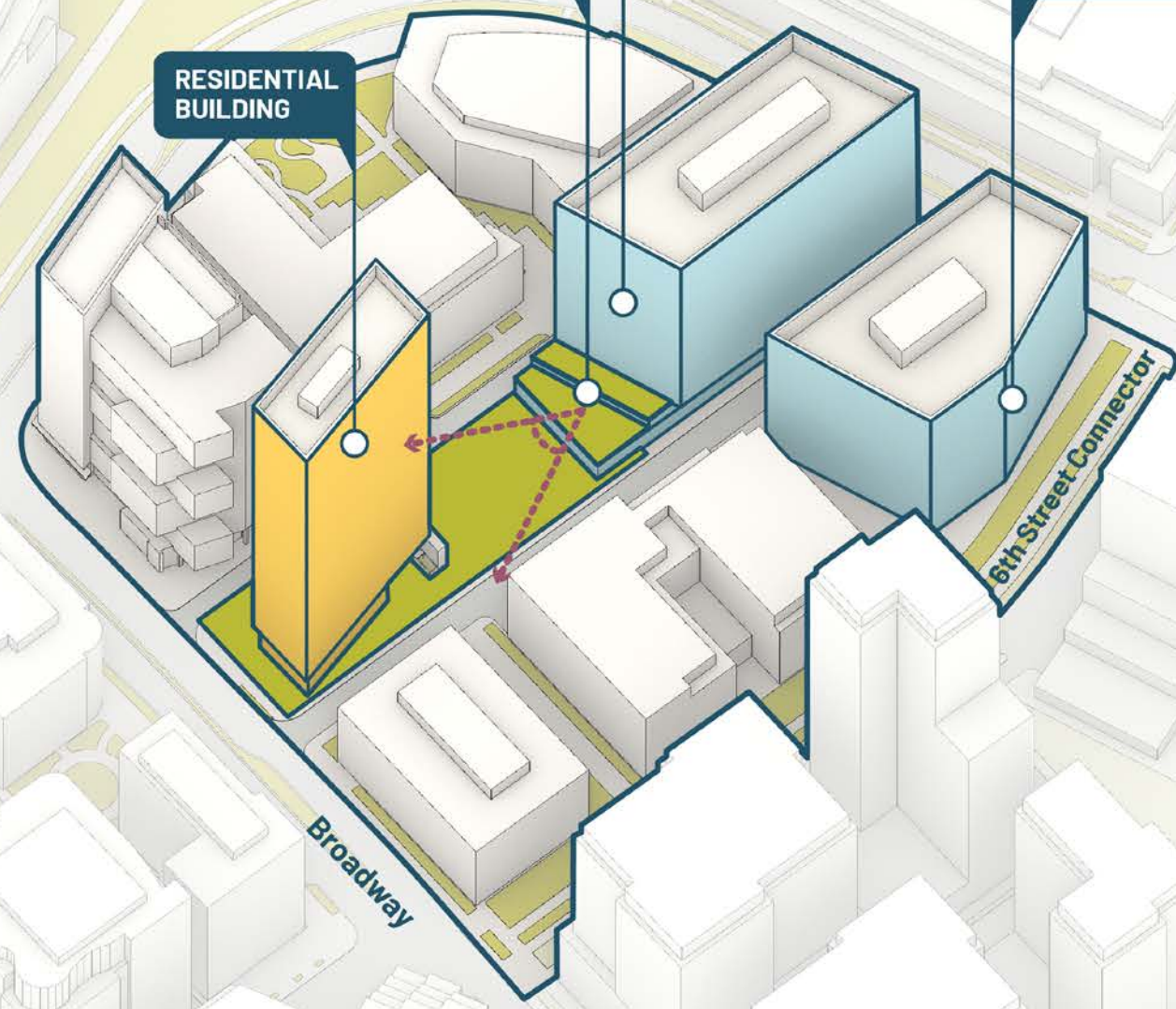

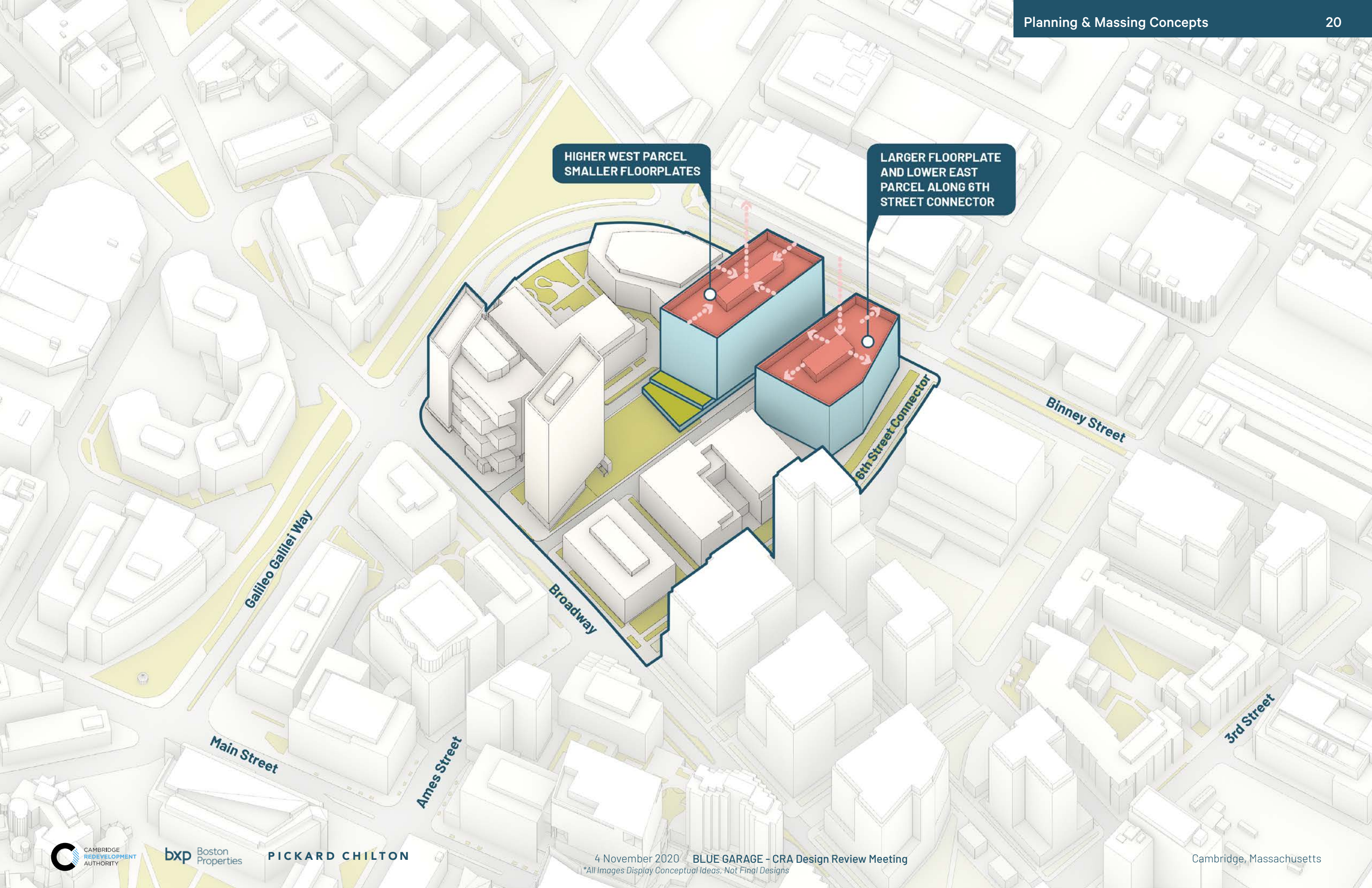

HIGHER WEST PARCEL
SMALLER FLOORPLATES

LARGER FLOORPLATE AND LOWER
EAST PARCEL ALONG 6TH
STREET CONNECTOR

Galileo Galilei Way

Broadway

6th Street Connector

Binney Street

Main Street

Ames Street

3rd Street



bxp Boston Properties

PICKARD CHILTON

4 November 2020 BLUE GARAGE - CRA Design Review Meeting
**All Images Display Conceptual Ideas, Not Final Designs*

Cambridge, Massachusetts

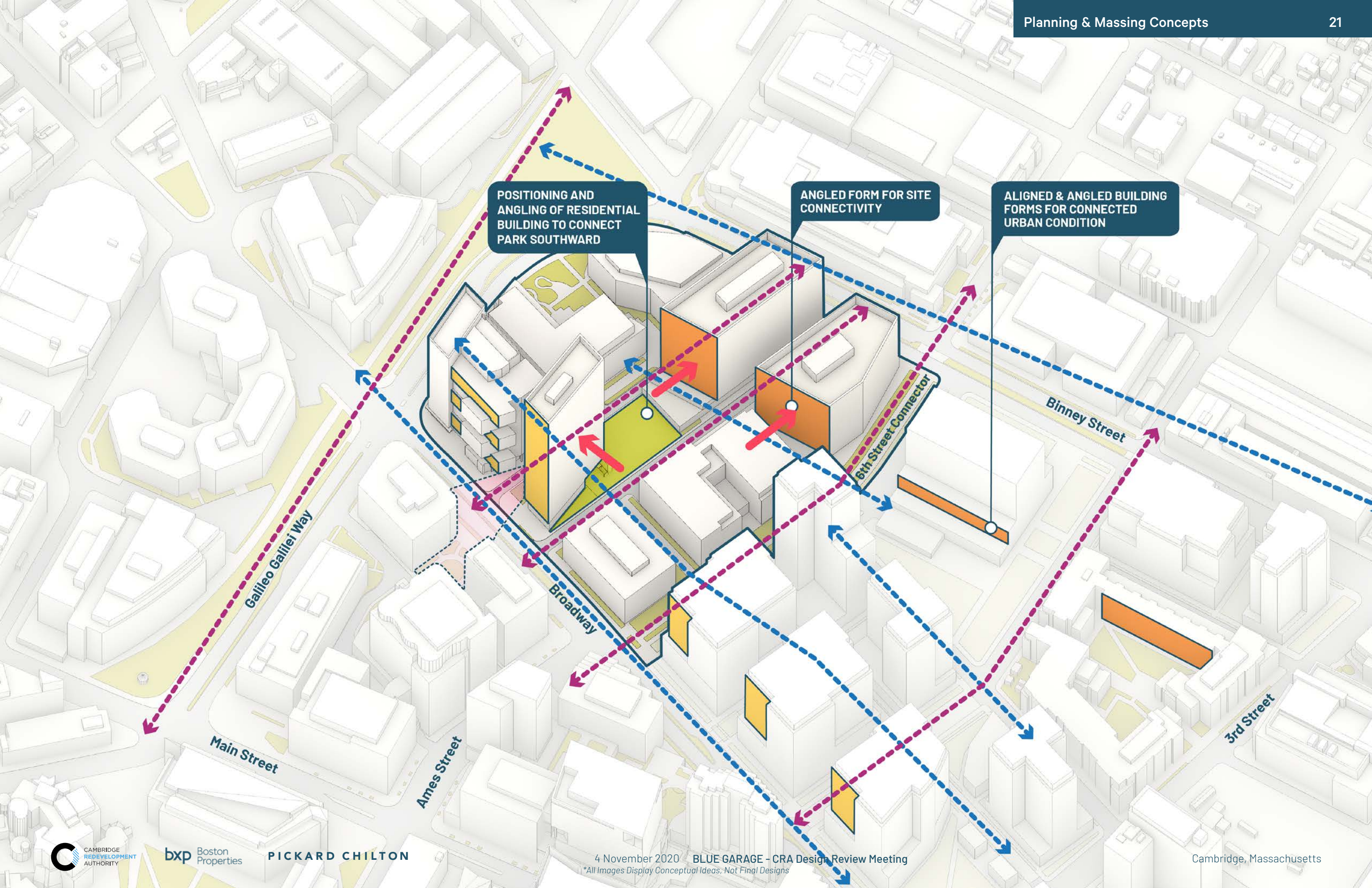

POSITIONING AND ANGLING OF RESIDENTIAL BUILDING TO CONNECT PARK SOUTHWARD

ANGLED FORM FOR SITE CONNECTIVITY

ALIGNED & ANGLED BUILDING FORMS FOR CONNECTED URBAN CONDITION

Galileo Galilei Way

Broadway

6th Street Connector

Binney Street

Main Street

Ames Street

3rd Street



bxp Boston Properties

PICKARD CHILTON

4 November 2020 BLUE GARAGE - CRA Design Review Meeting
 *All Images Display Conceptual Ideas, Not Final Designs

Cambridge, Massachusetts

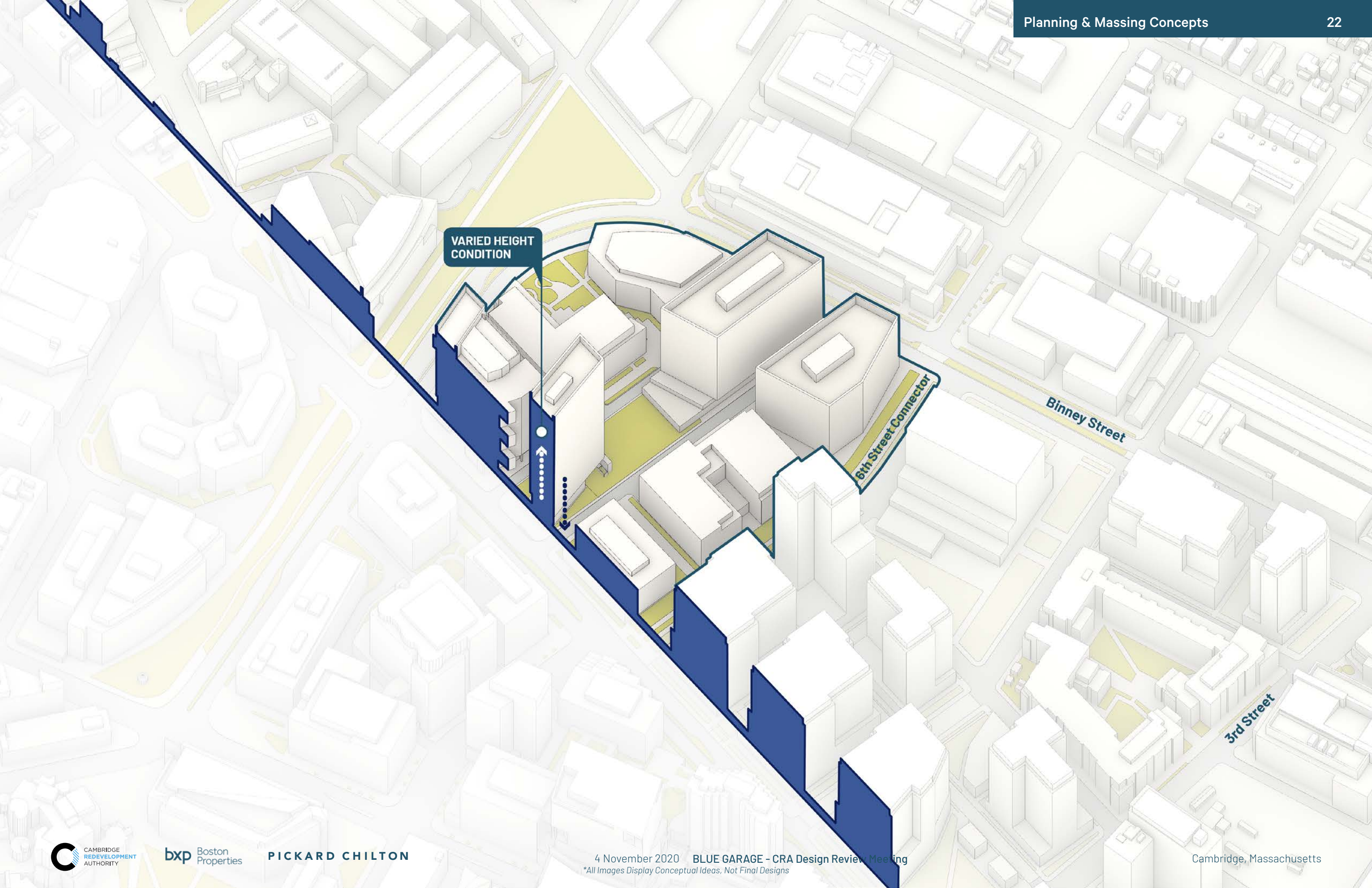

VARIED HEIGHT CONDITION

6th Street Connector

Binney Street

3rd Street

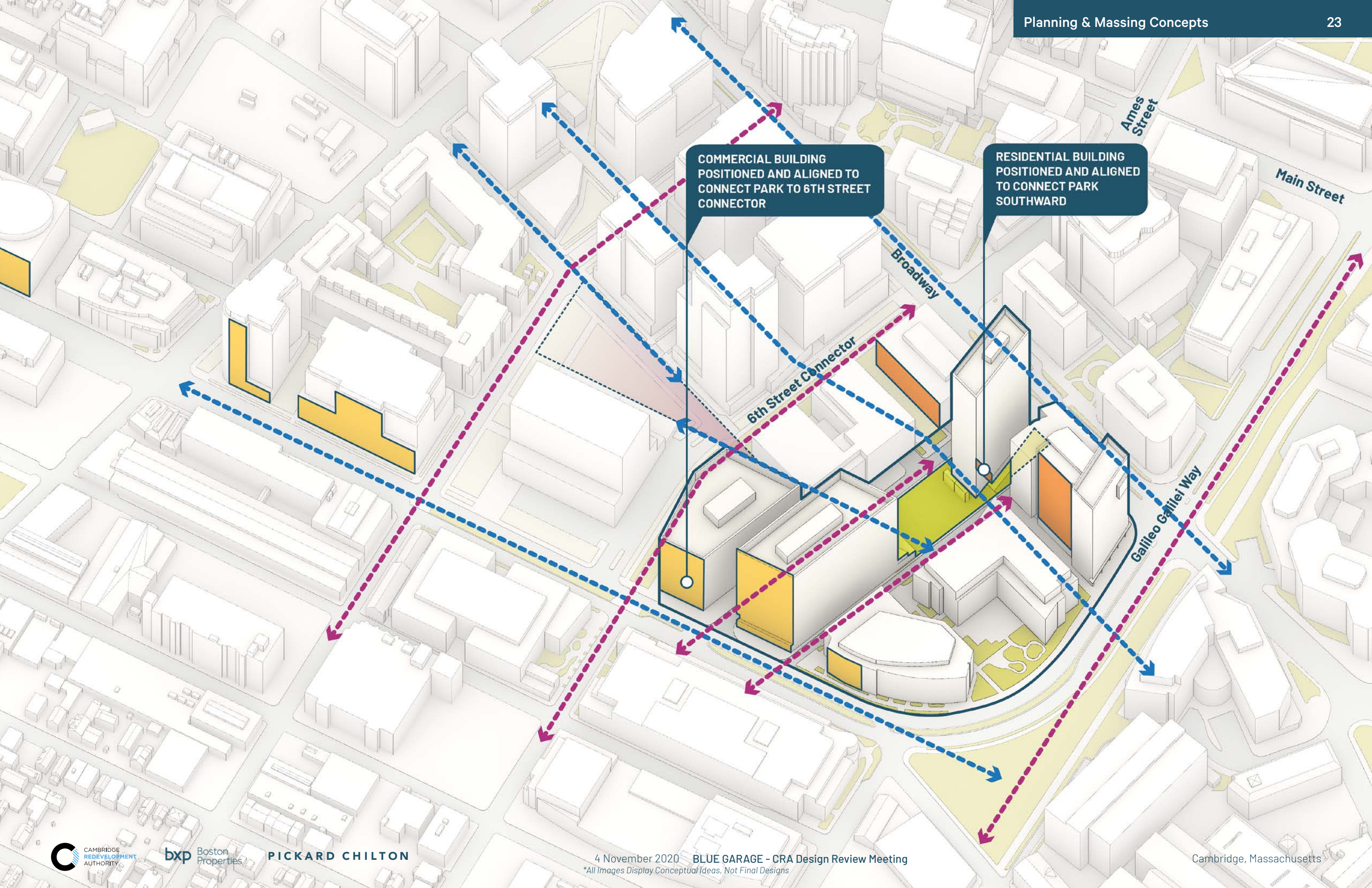

COMMERCIAL BUILDING POSITIONED AND ALIGNED TO CONNECT PARK TO 6TH STREET CONNECTOR

RESIDENTIAL BUILDING POSITIONED AND ALIGNED TO CONNECT PARK SOUTHWARD

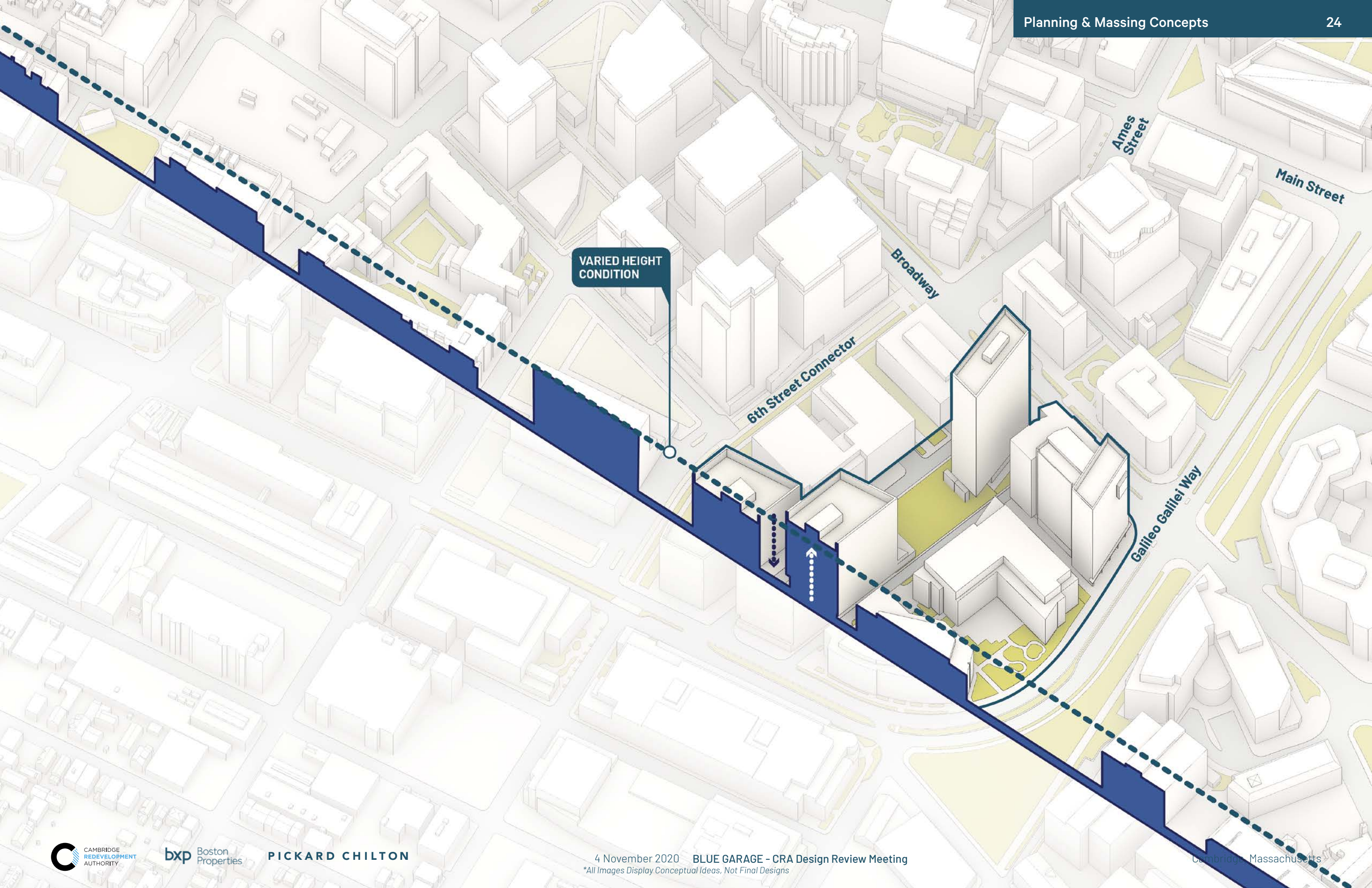

VARIED HEIGHT
CONDITION

Ames Street

Main Street

Broadway

6th Street Connector

Galileo Galilei Way

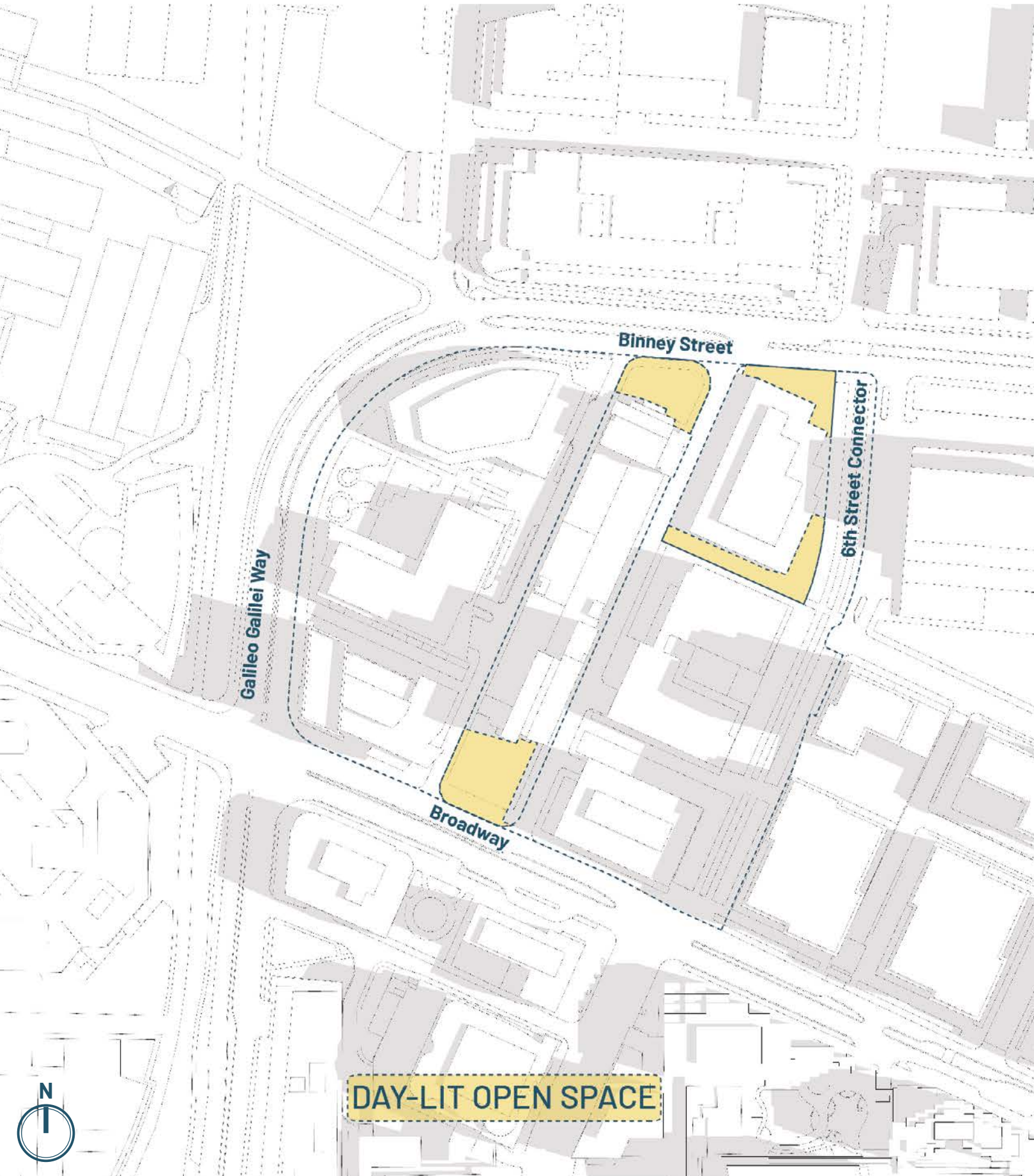

DAY-LIT OPEN SPACE

MXD MASSING

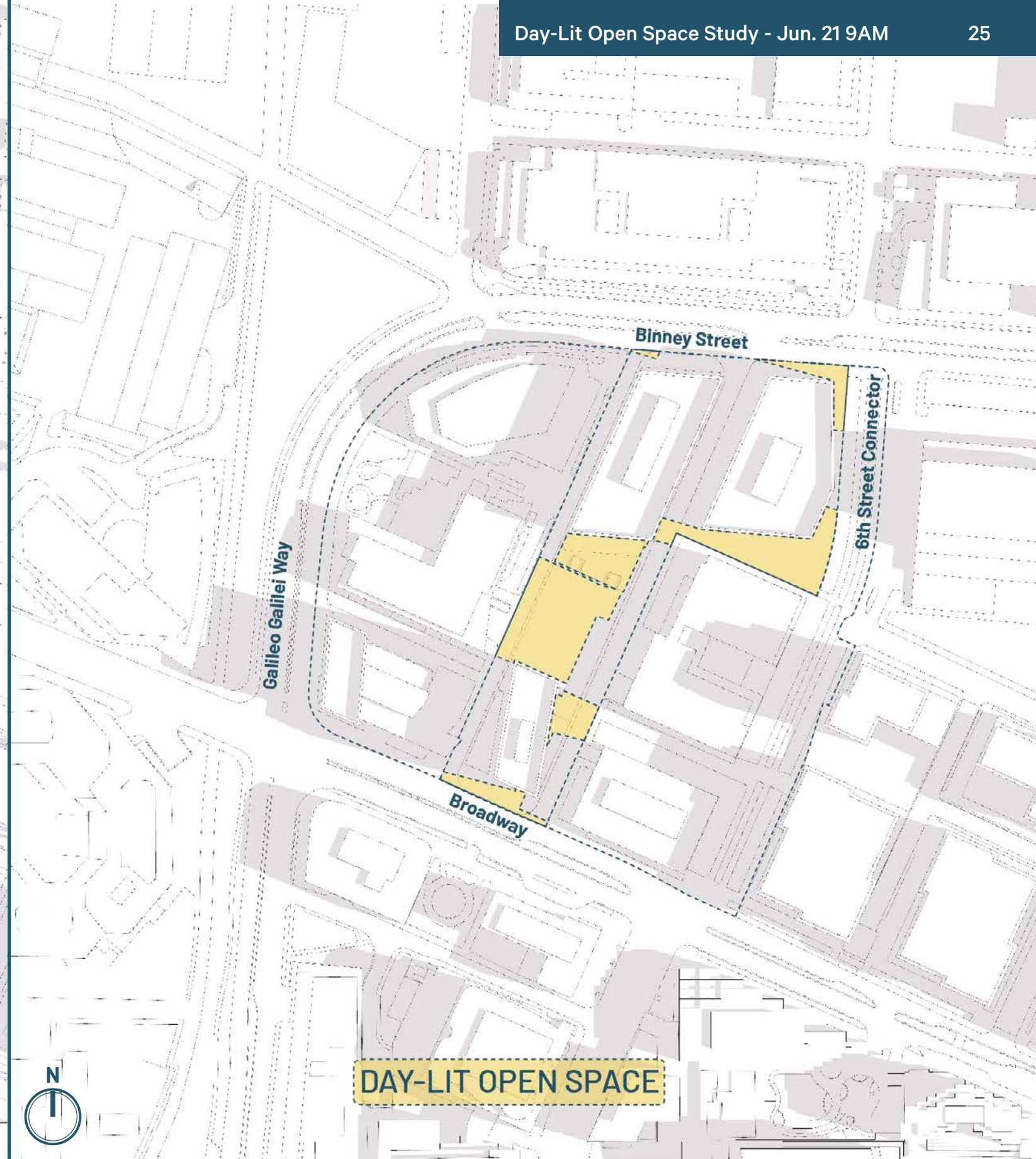

DAY-LIT OPEN SPACE

PROPOSED

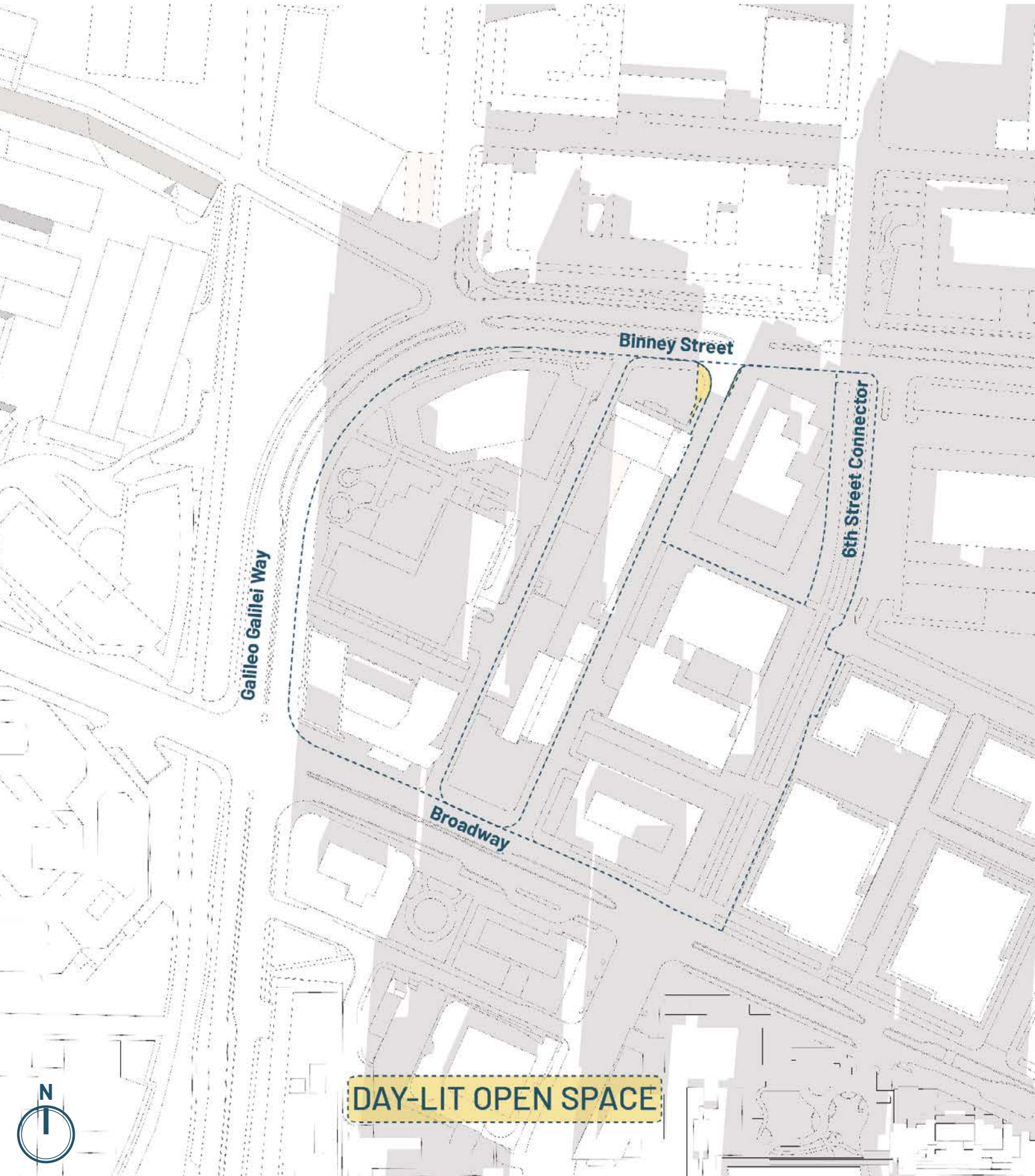

MXD MASSING

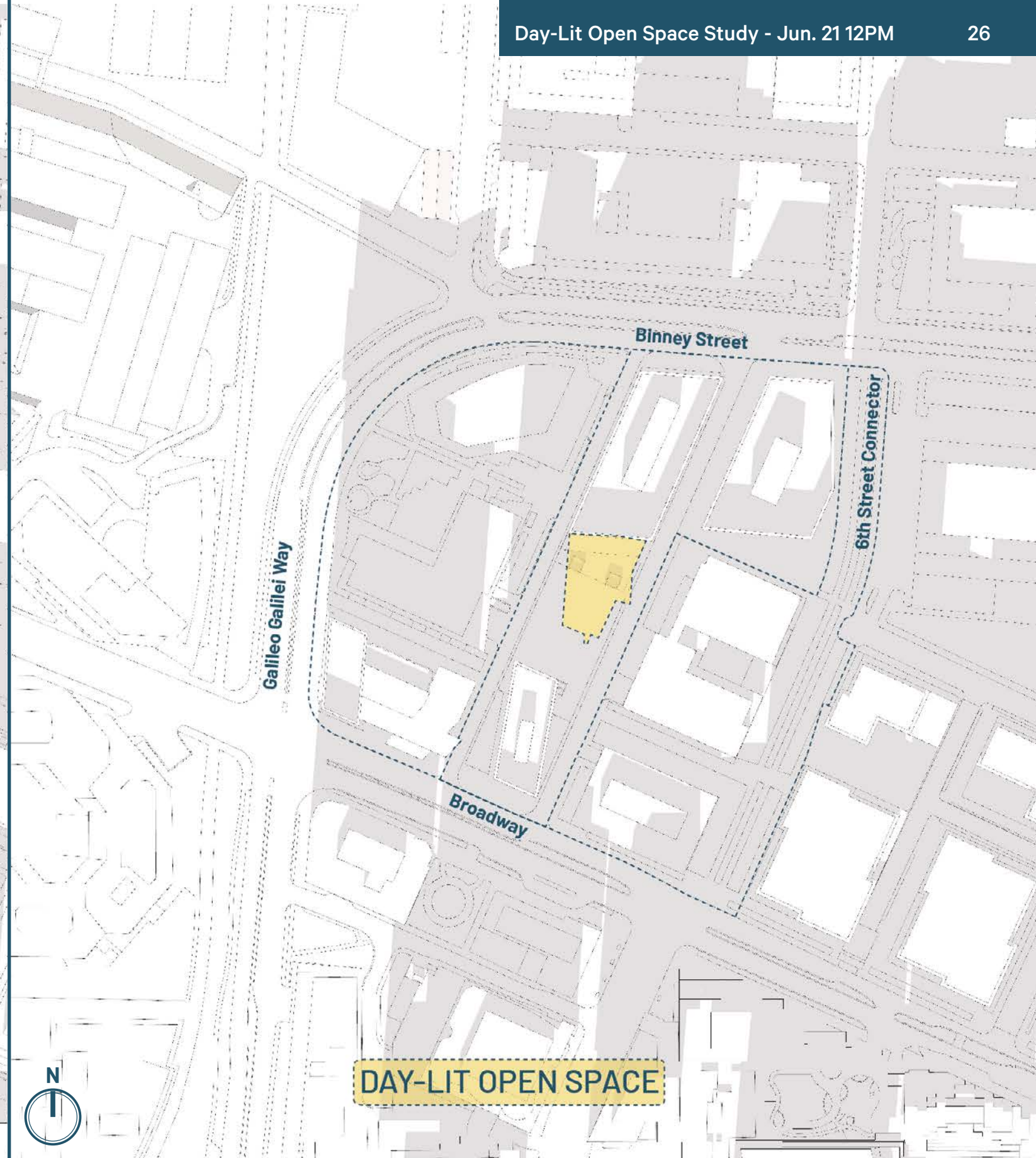

PROPOSED

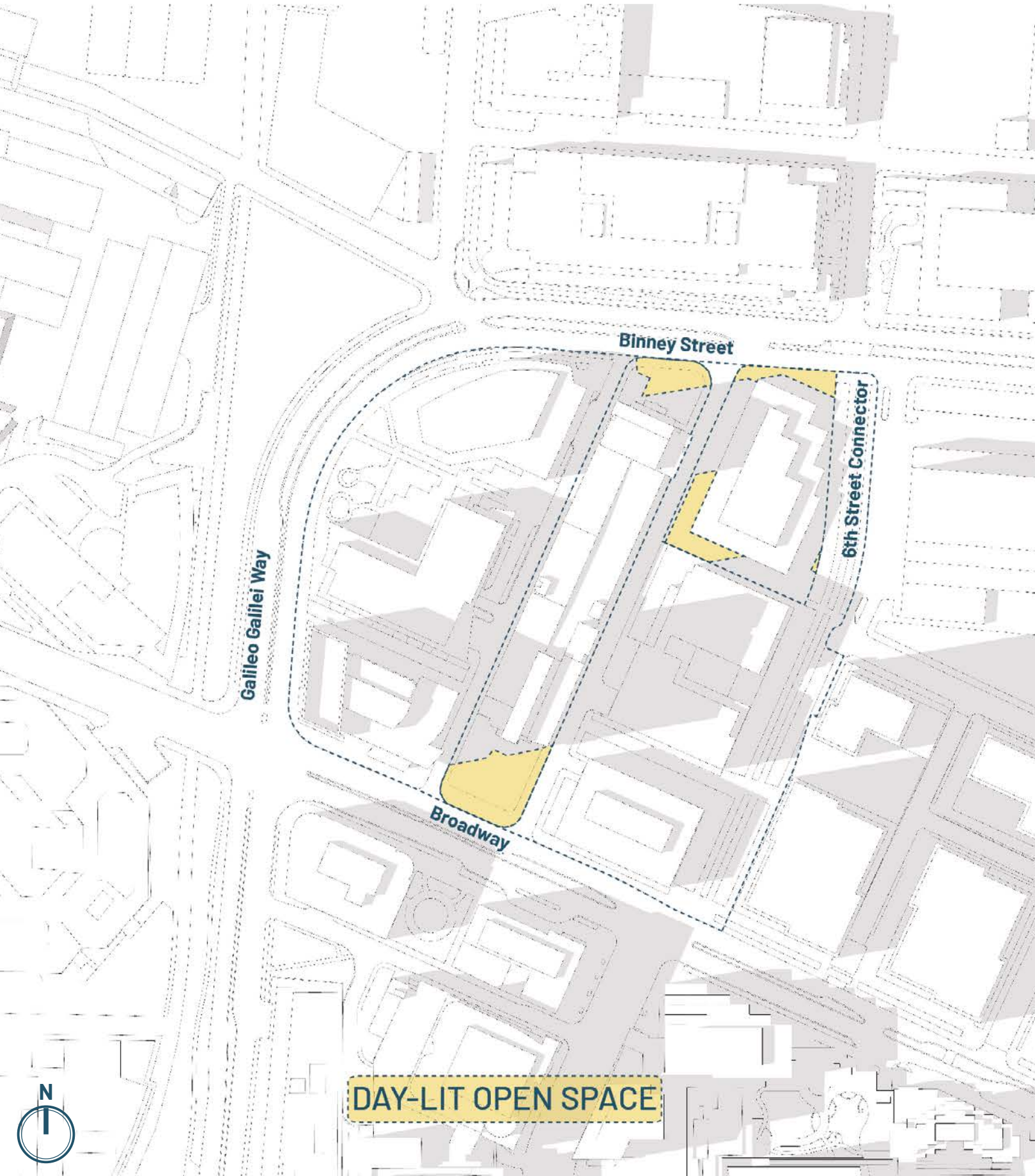

MXD MASSING

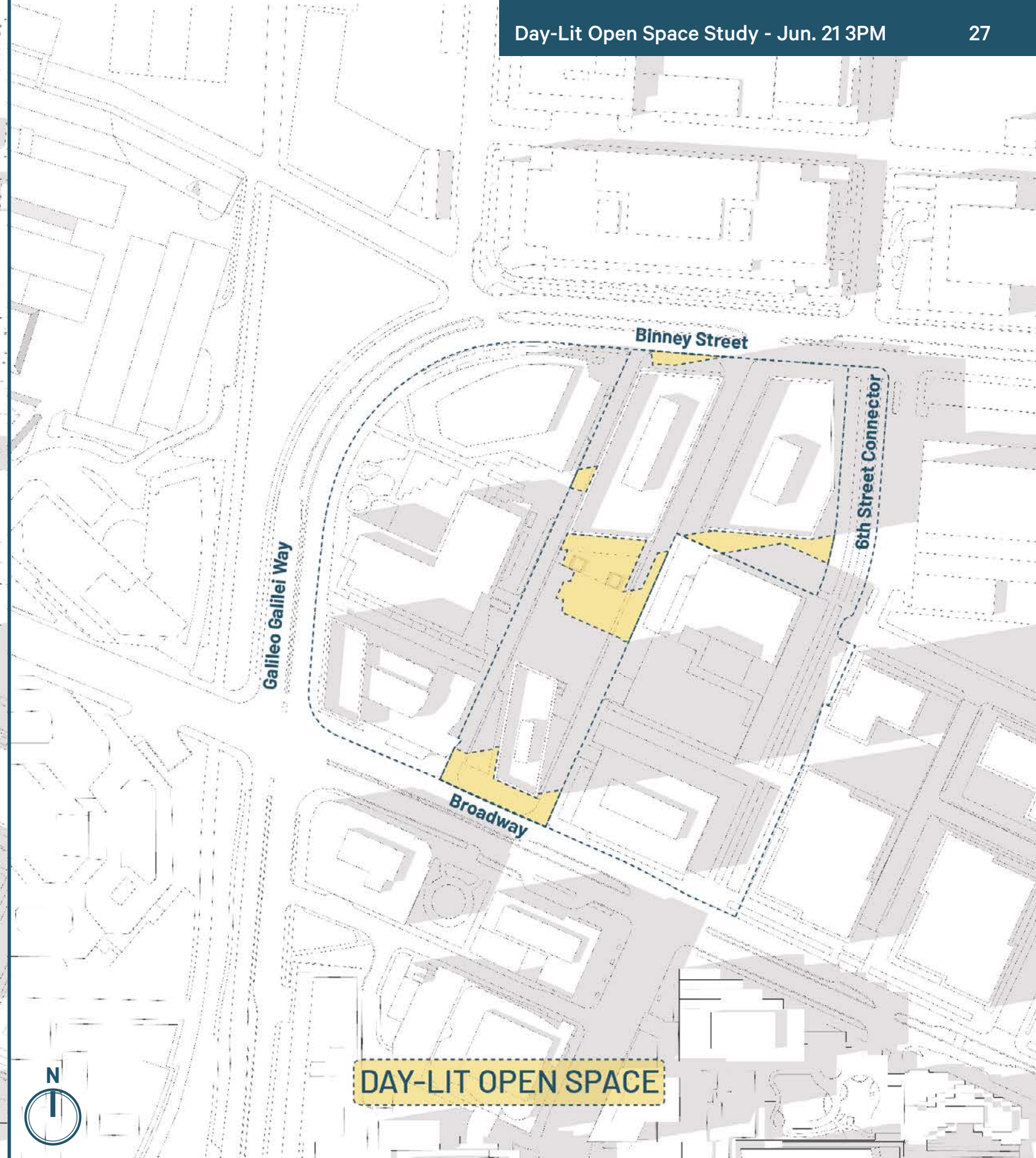

PROPOSED

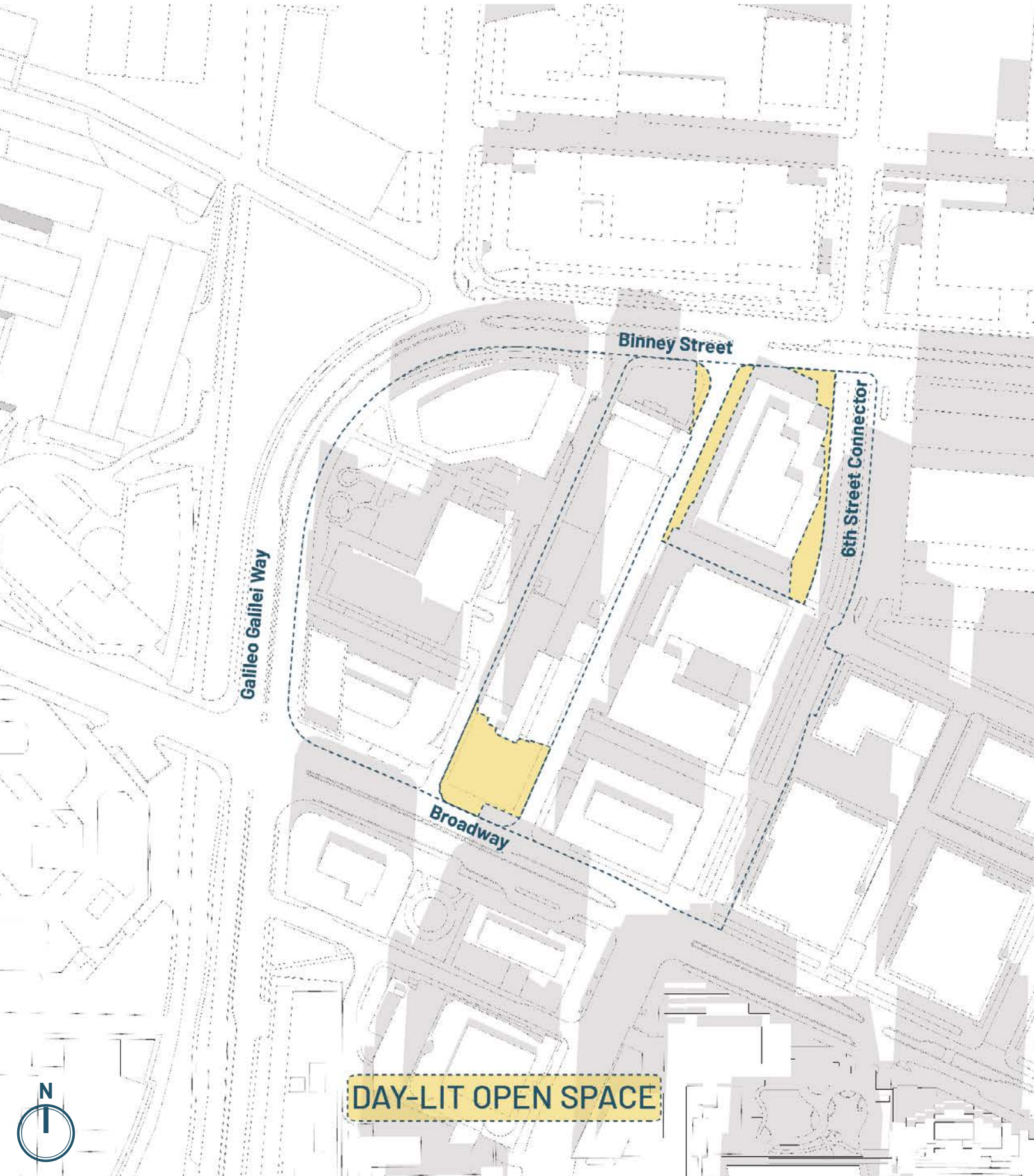

DAY-LIT OPEN SPACE

MXD MASSING

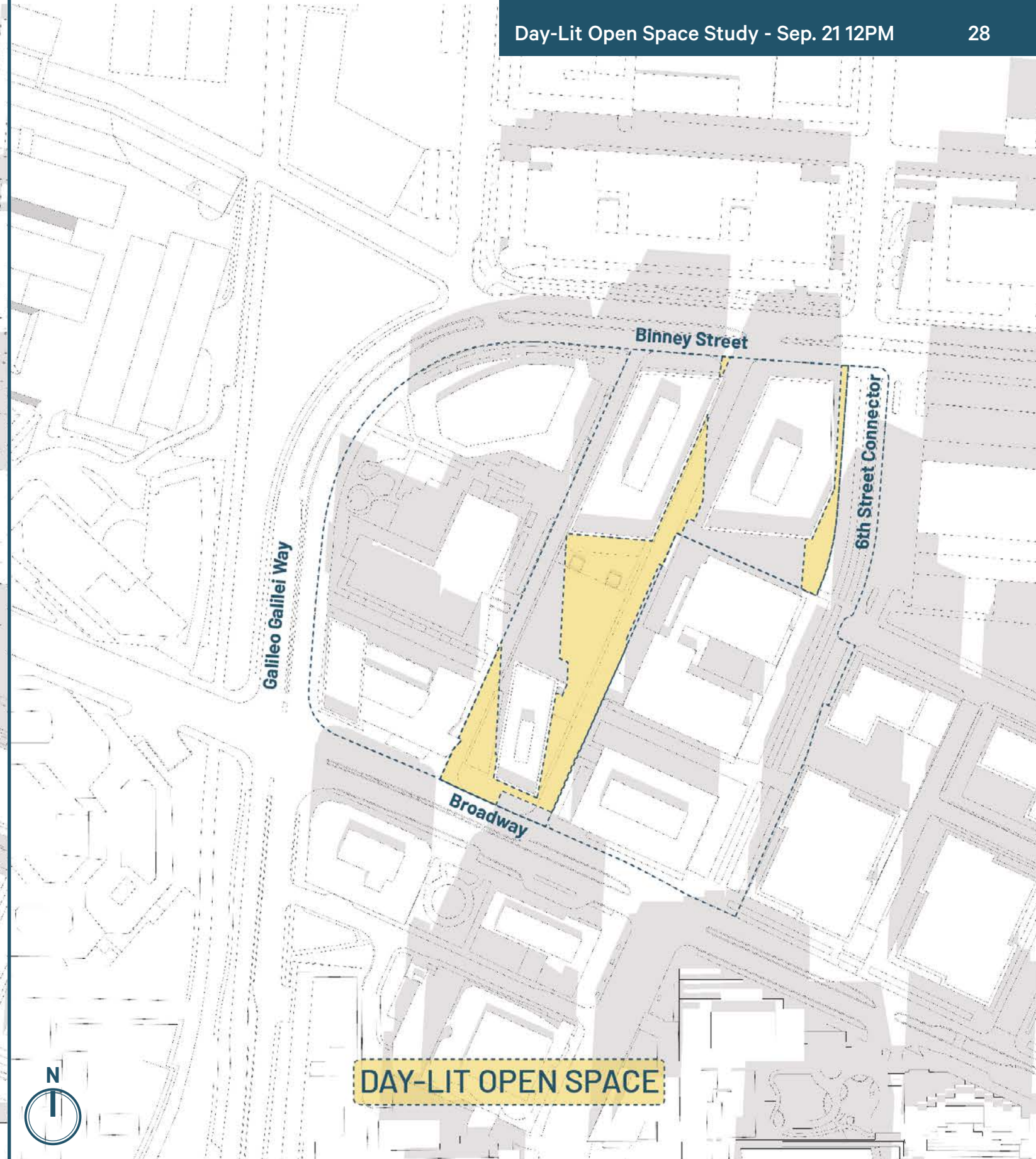

DAY-LIT OPEN SPACE

PROPOSED

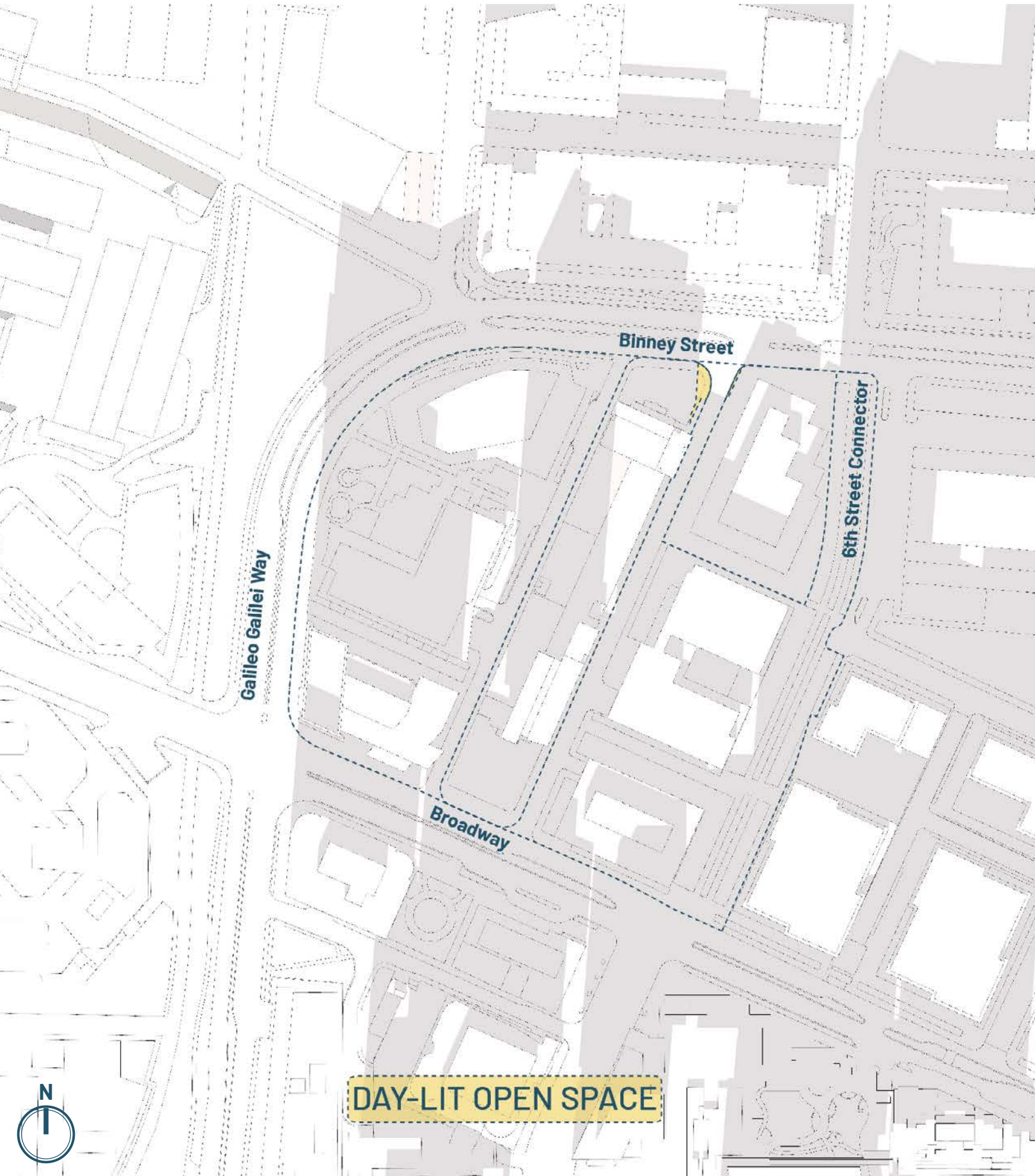

MXD MASSING

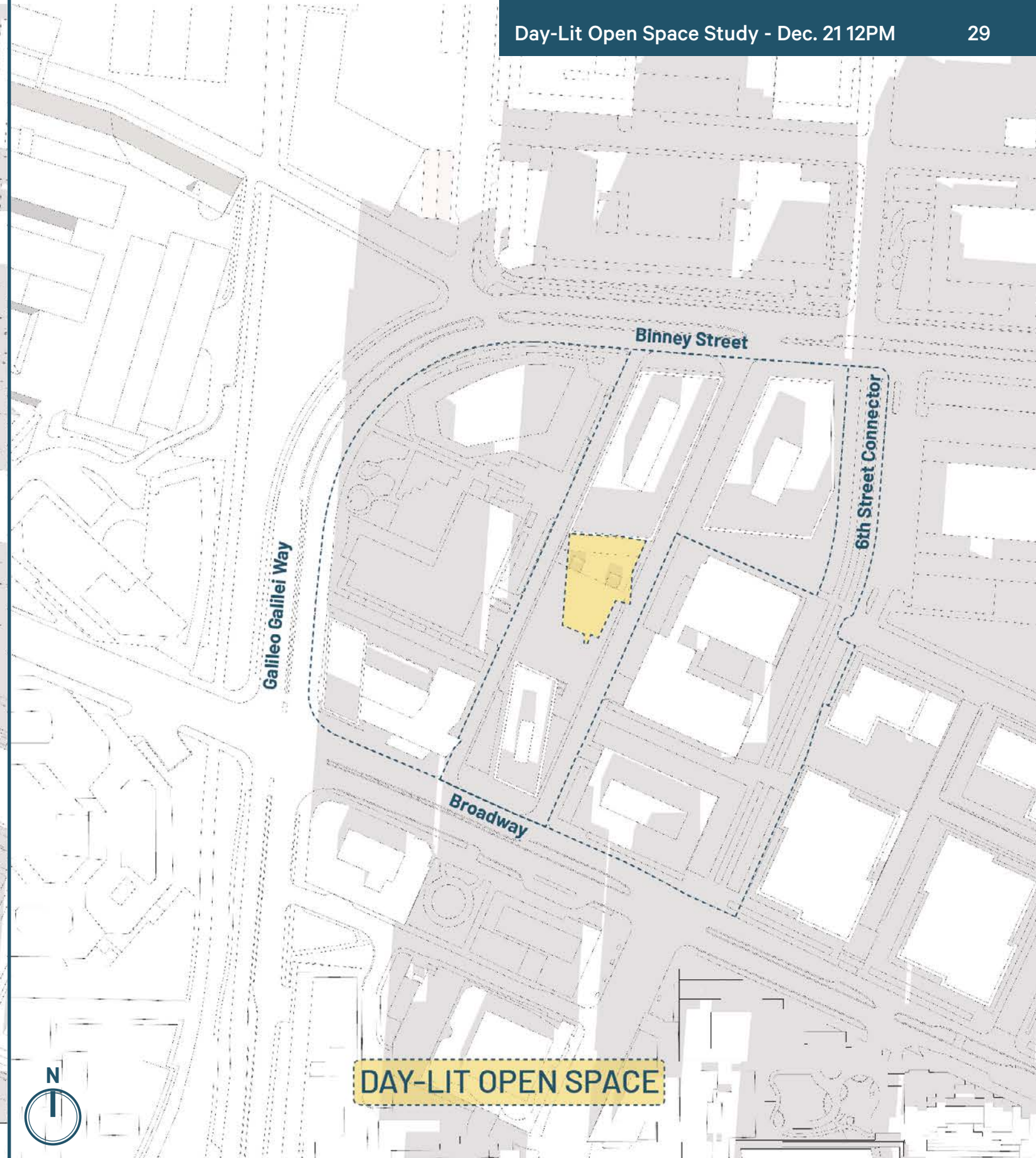

PROPOSED

VISION: Create a Wonderful Place Where



The Community can Flourish



All Feel Welcome and Included

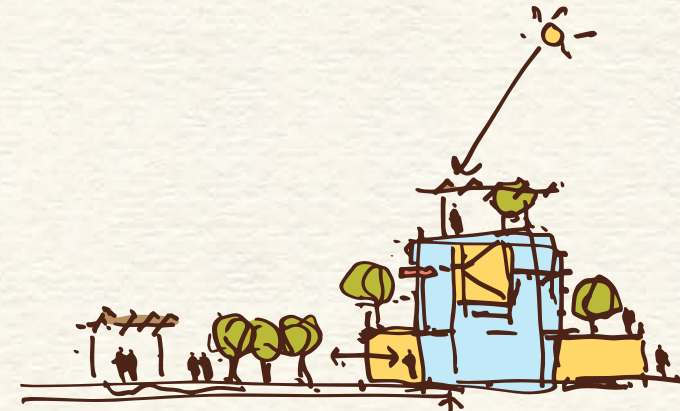

Sustainability, Resiliency, and Wellness Inform the Design

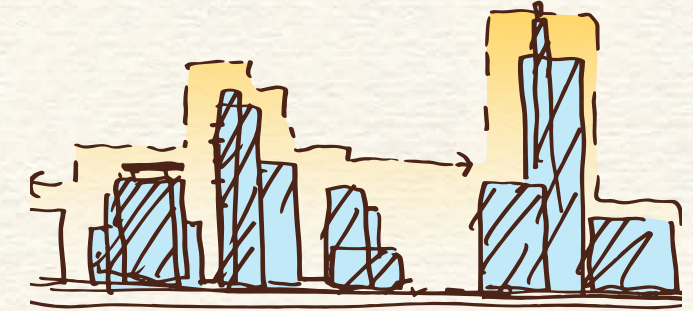

Diverse Urban Forms Create a Varied and Beautiful City Scape

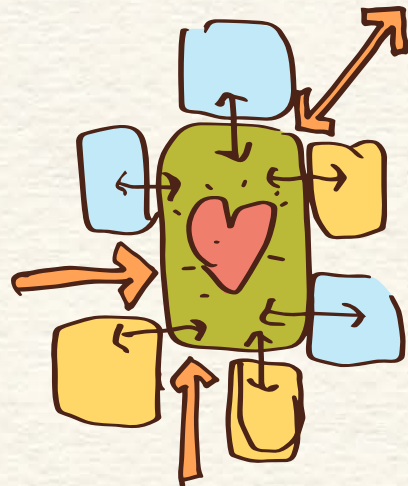

A Vibrant Central Space Connects to the Network of Cambridge Open Spaces



The Design Enriches and Activates the Public Realm



People, Bikes, and Cars Share the Urban Space

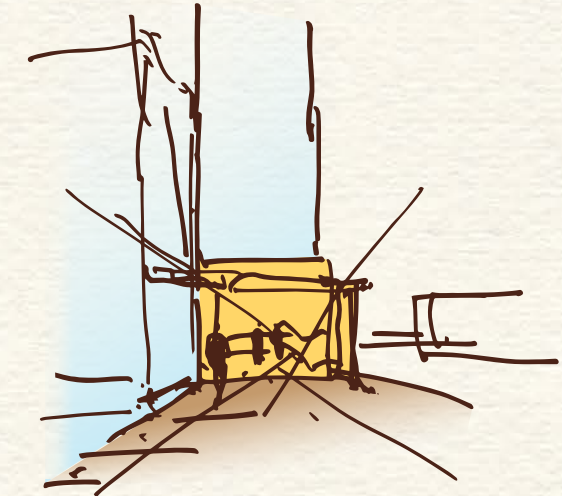

Thresholds and Framed Views Enrich the Experience

View of the Park from the Southeast

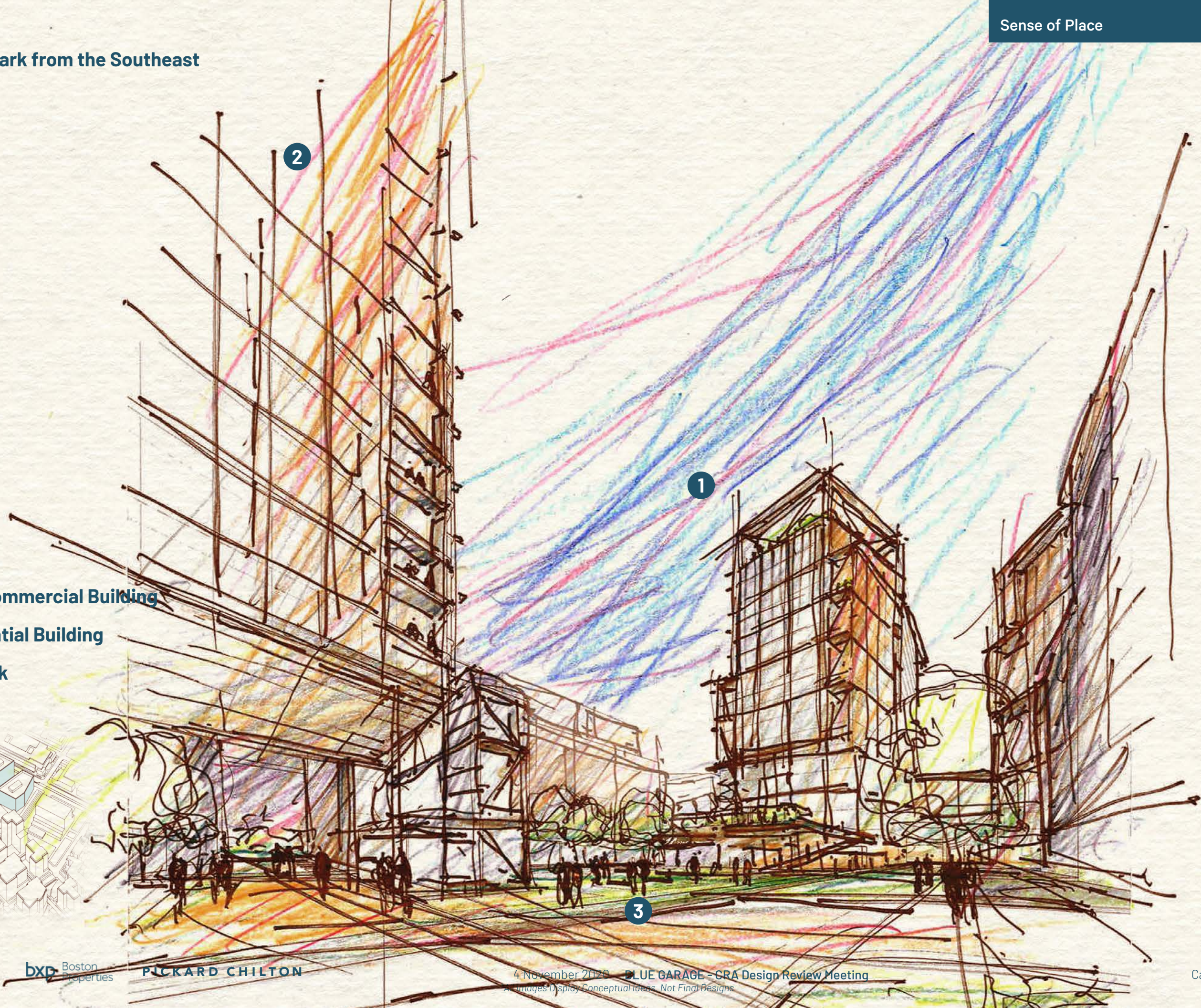

- 1** West Commercial Building
- 2** Residential Building
- 3** The Park

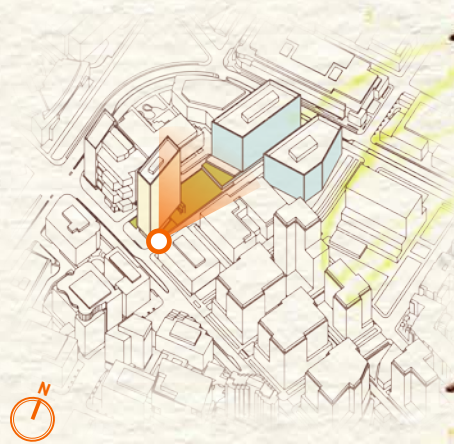

View of the Residential Building from Danny Lewin Park

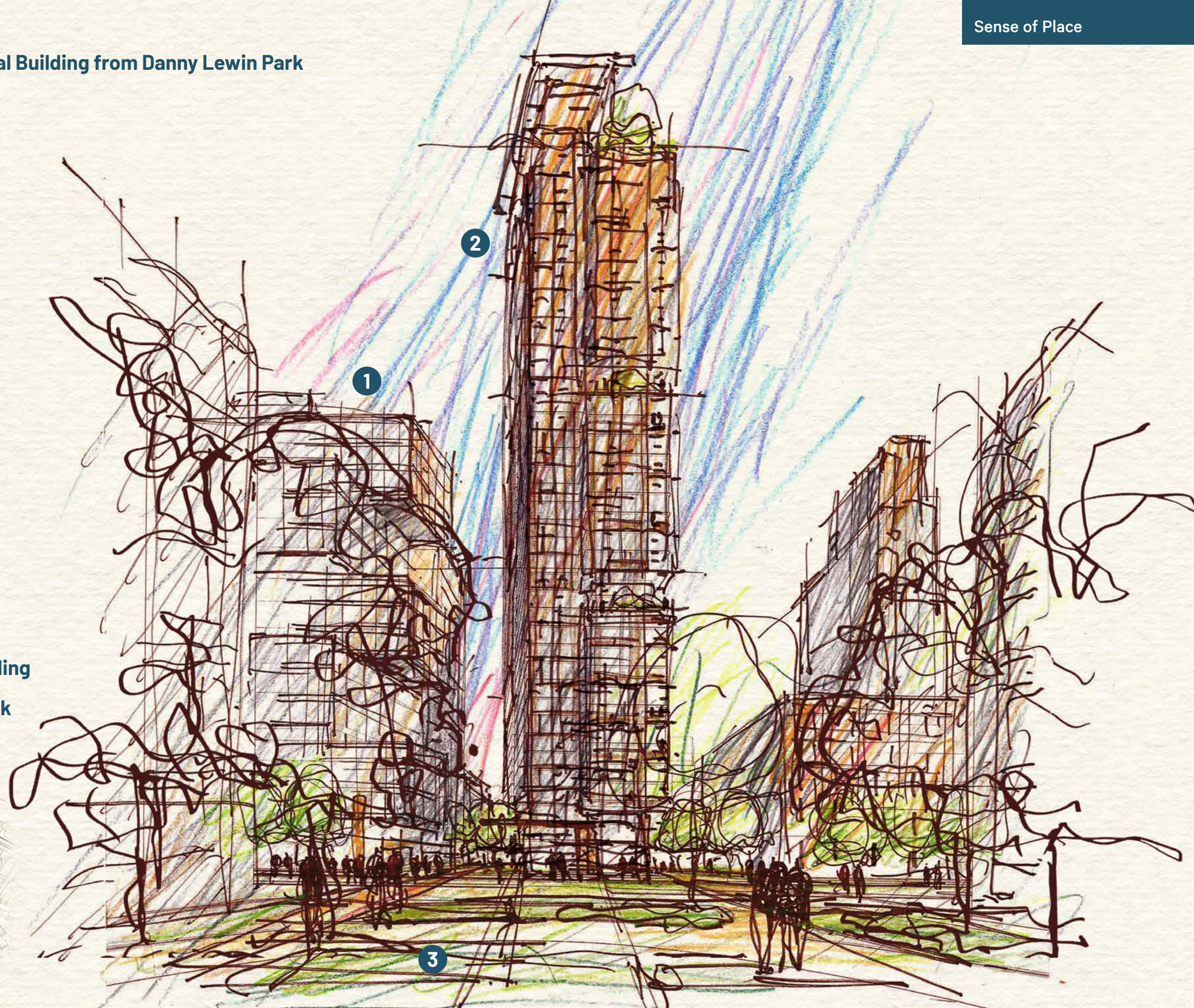

- 1** 145 Broadway
- 2** Residential Building
- 3** Danny Lewin Park

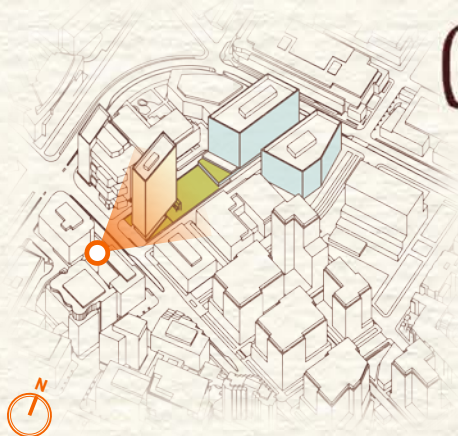

View of the Park from the Northeast, Second Level Terrace

- 1** Residential Building
- 2** The Park
- 3** Second Level Terrace Overlooking the Park

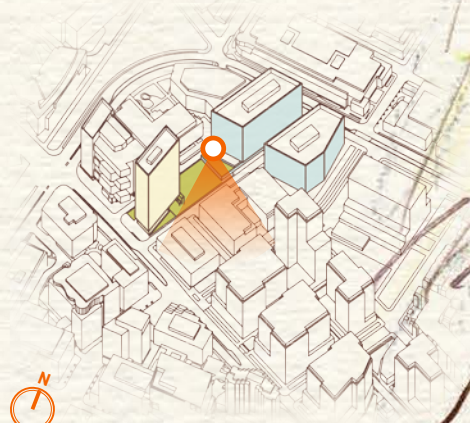

View of the Commercial Building from the Northeast (Intersection of Binney Street and the 6th Street Connector)

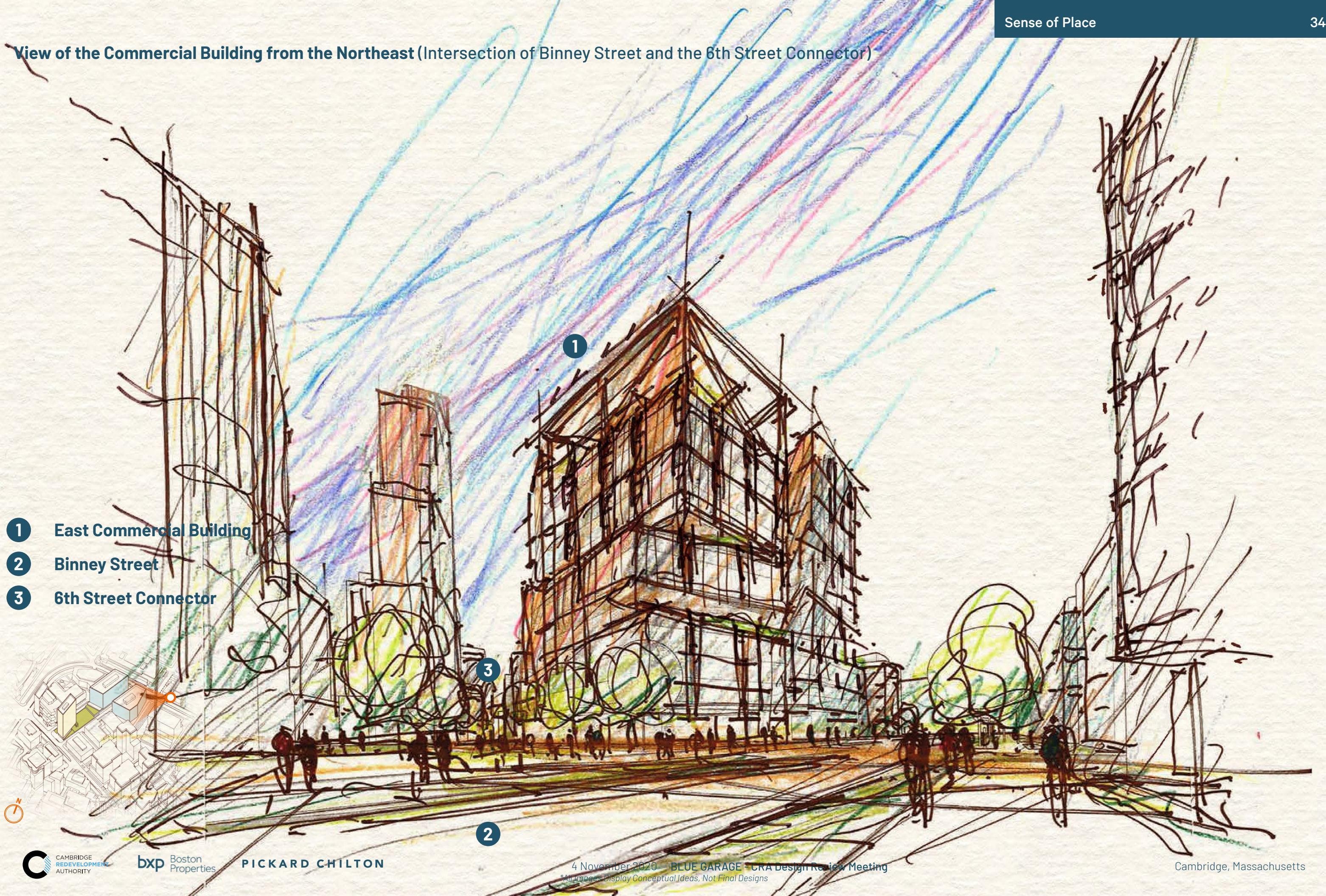

- 1 East Commercial Building
- 2 Binney Street
- 3 6th Street Connector

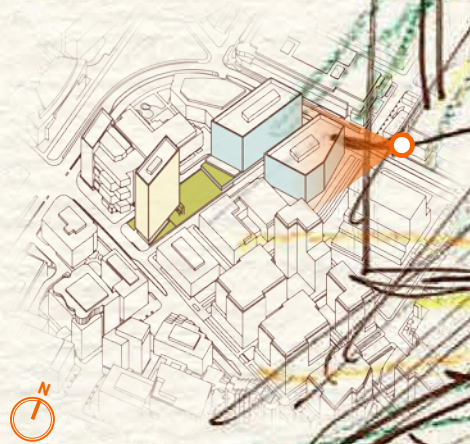

View of the Park from the Southeast (Vople to Porkchop Park Connector)

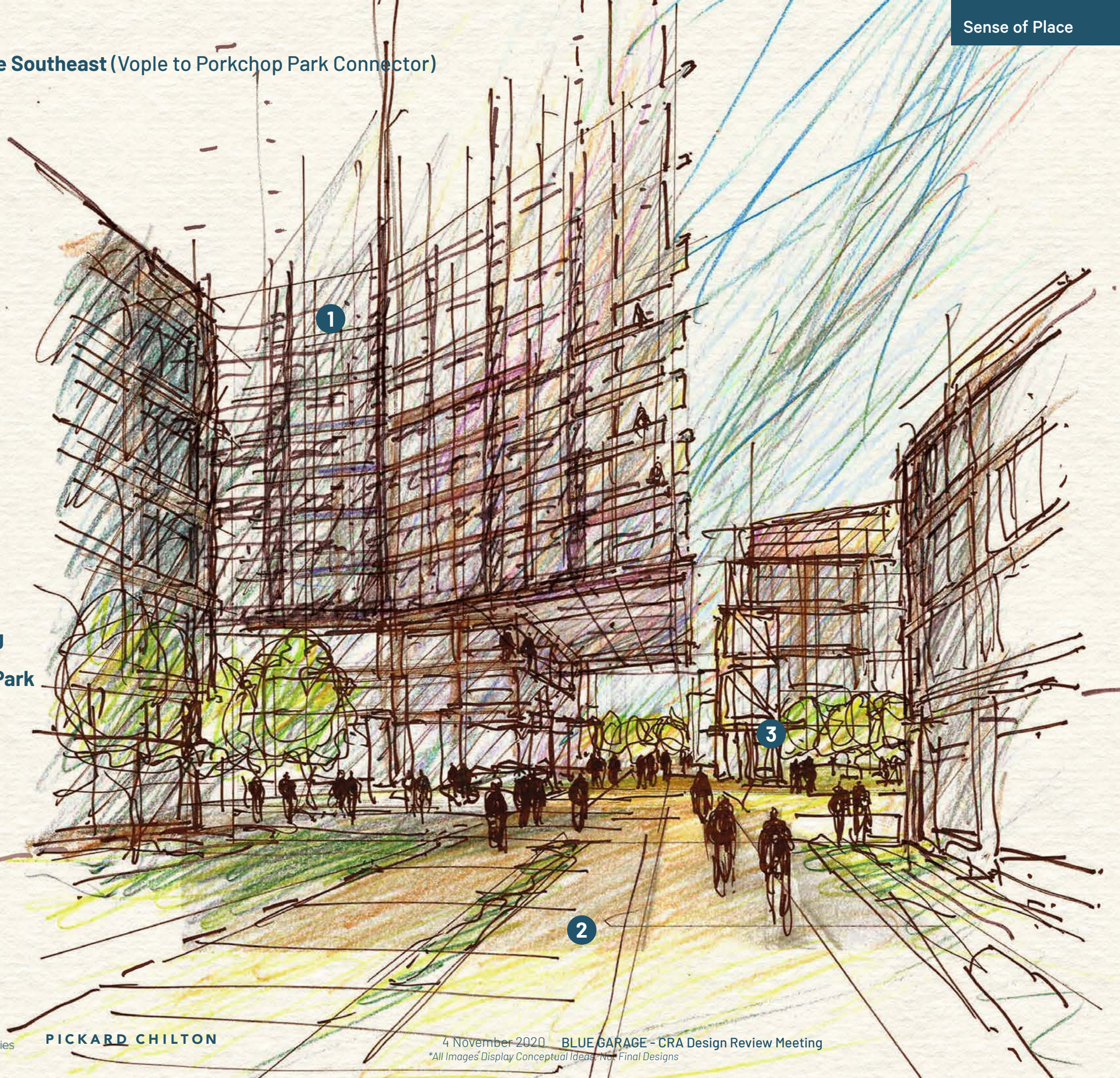

- 1 Residential Building
- 2 Volpe to Porkchop Park Connector
- 3 The Park

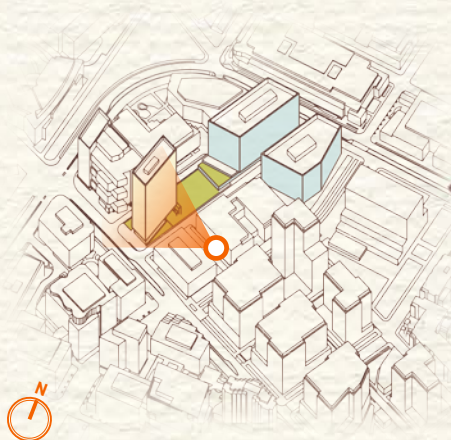

POTENTIAL TERRACES, PROJECTIONS / CUTS TO CREATE ARTICULATED FORMS

POTENTIAL VERTICAL BREAKS TO ACTIVATE THE FACADES

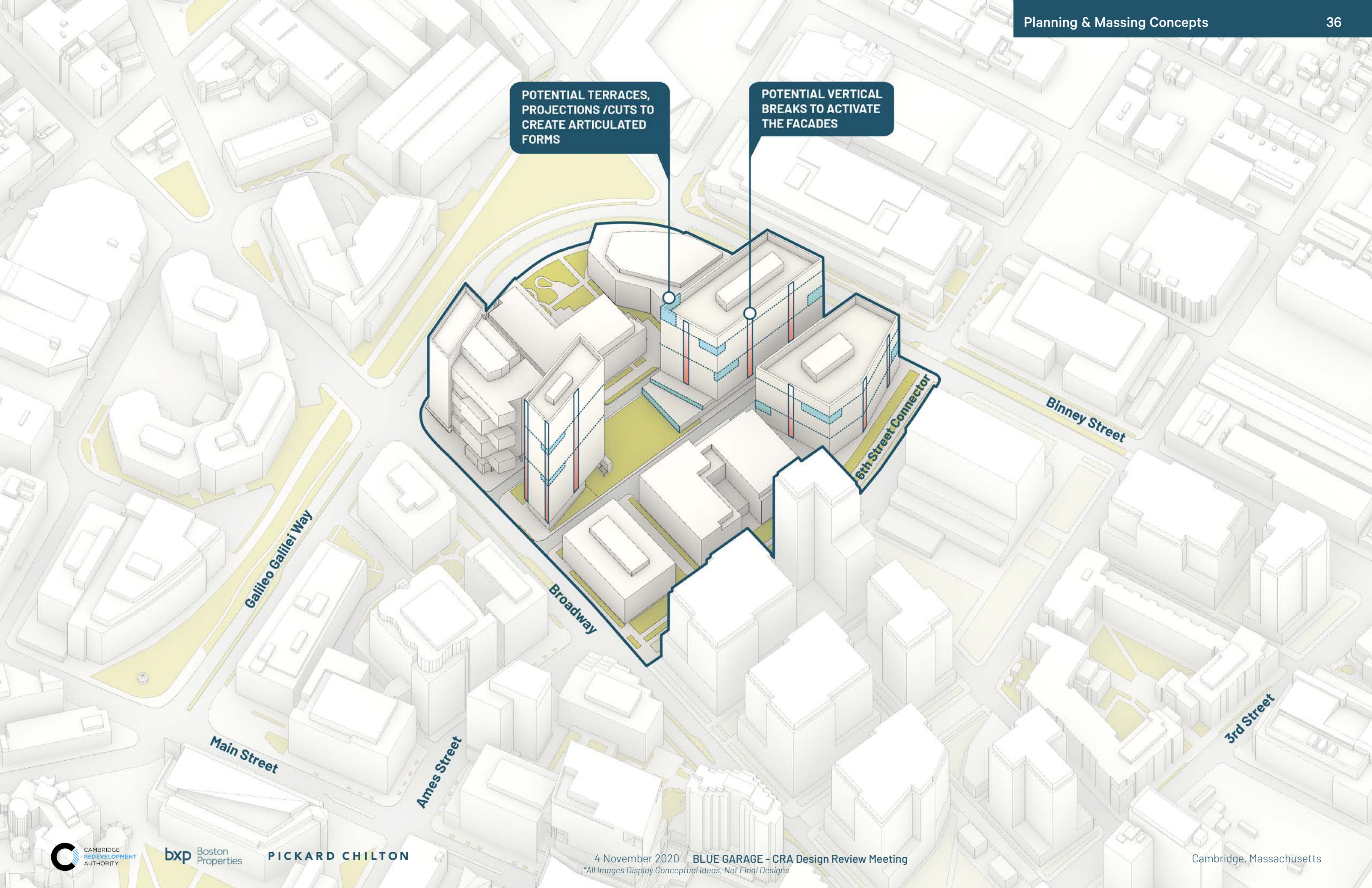

Galileo Galilei Way

Broadway

6th Street Connector

Binney Street

Main Street

Ames Street

3rd Street



bxp Boston Properties

PICKARD CHILTON

4 November 2020 BLUE GARAGE - CRA Design Review Meeting
*All Images Display Conceptual Ideas, Not Final Designs

Cambridge, Massachusetts

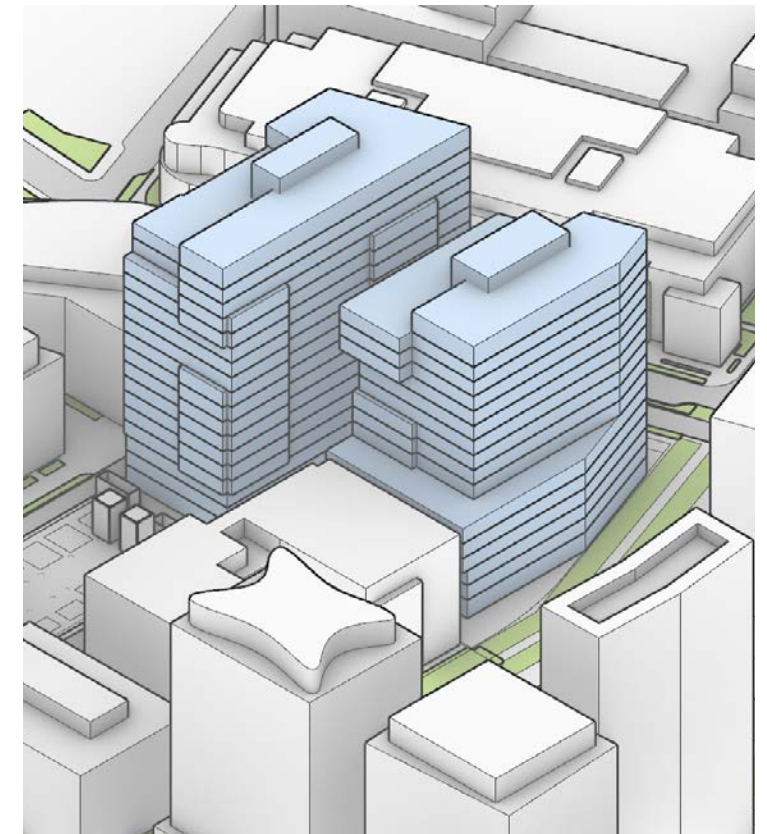
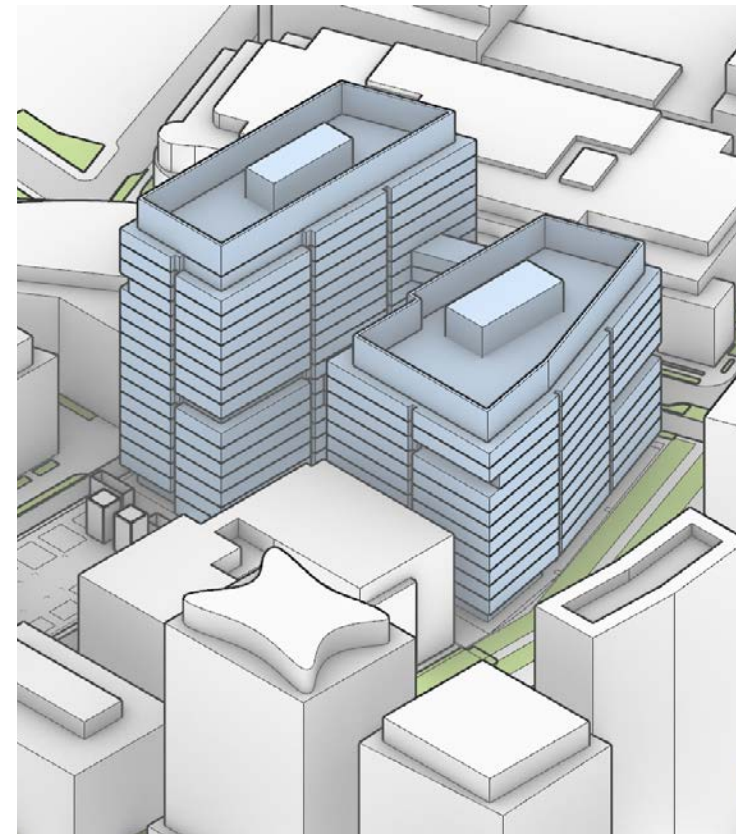
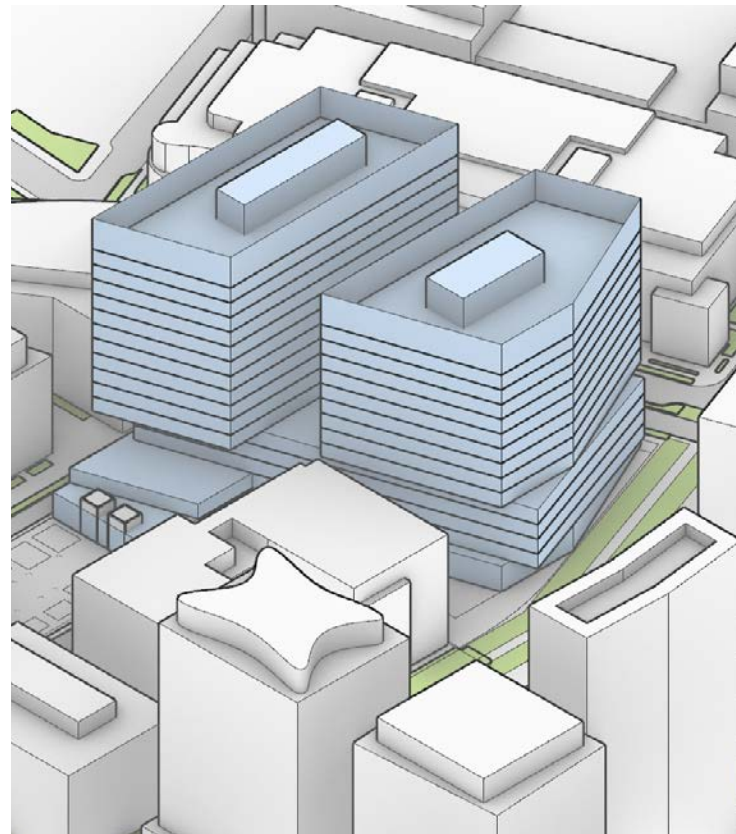
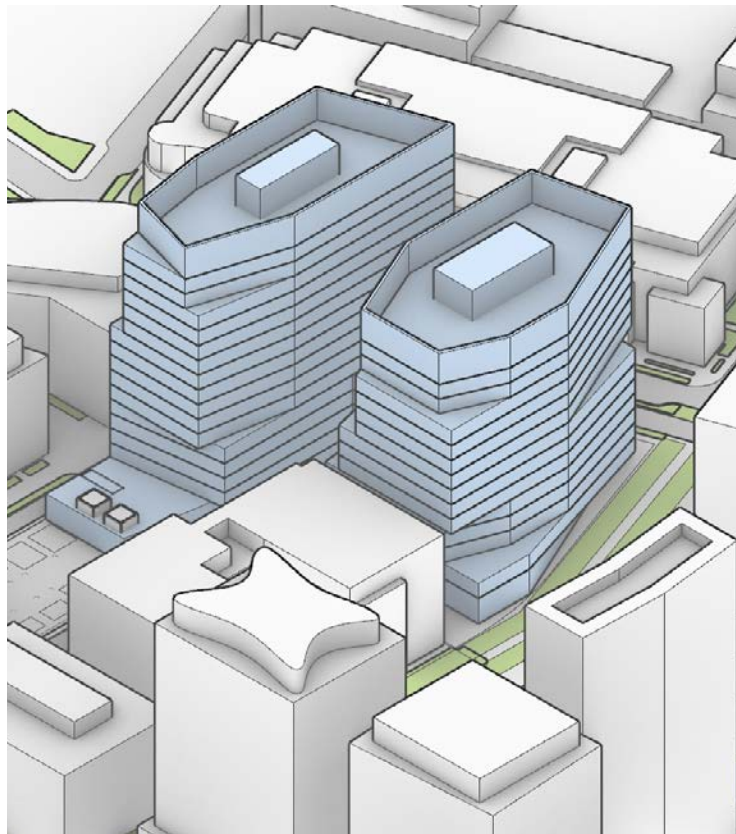
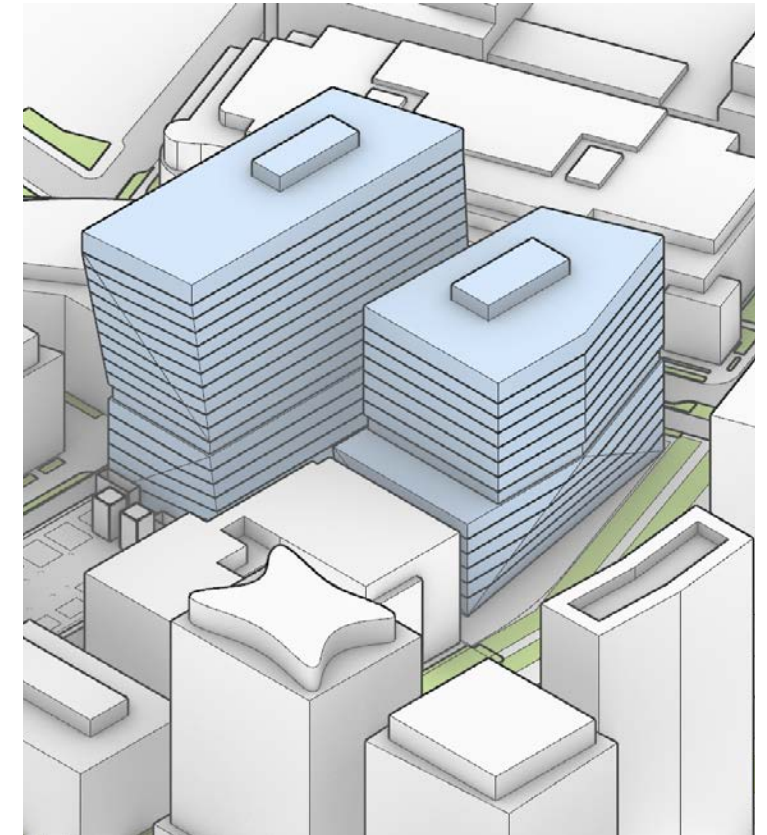
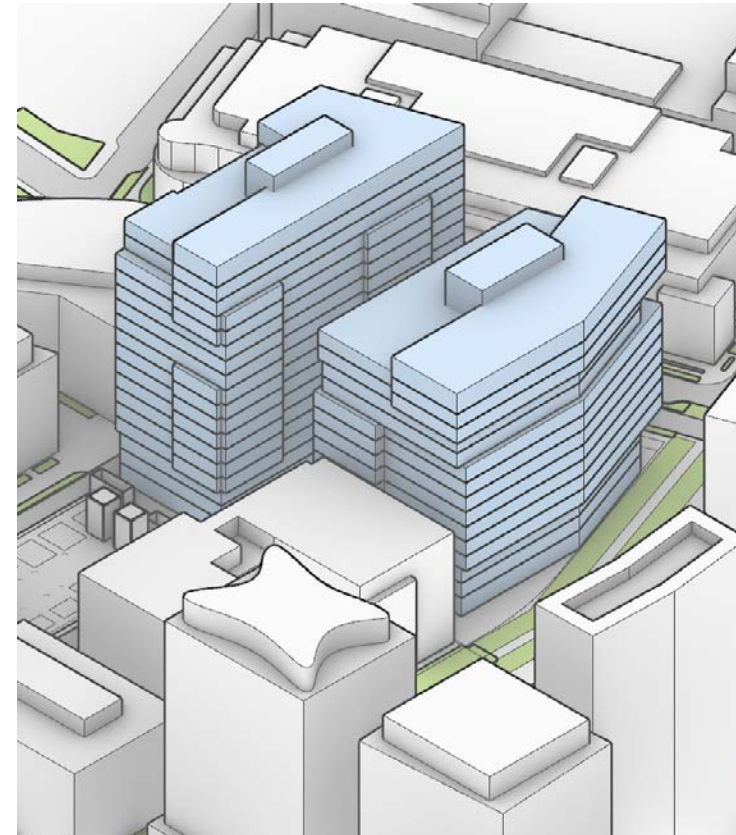
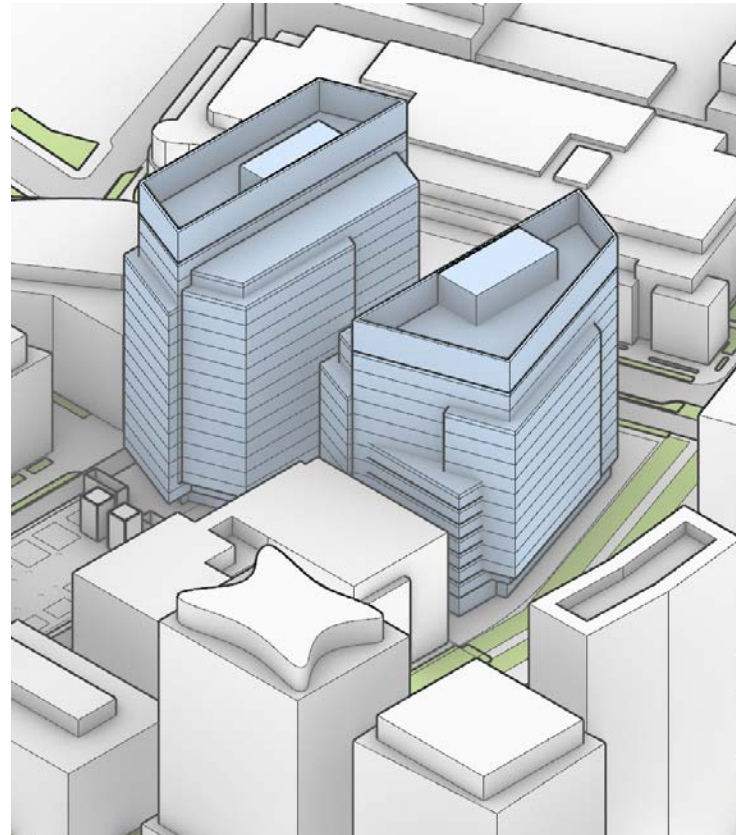
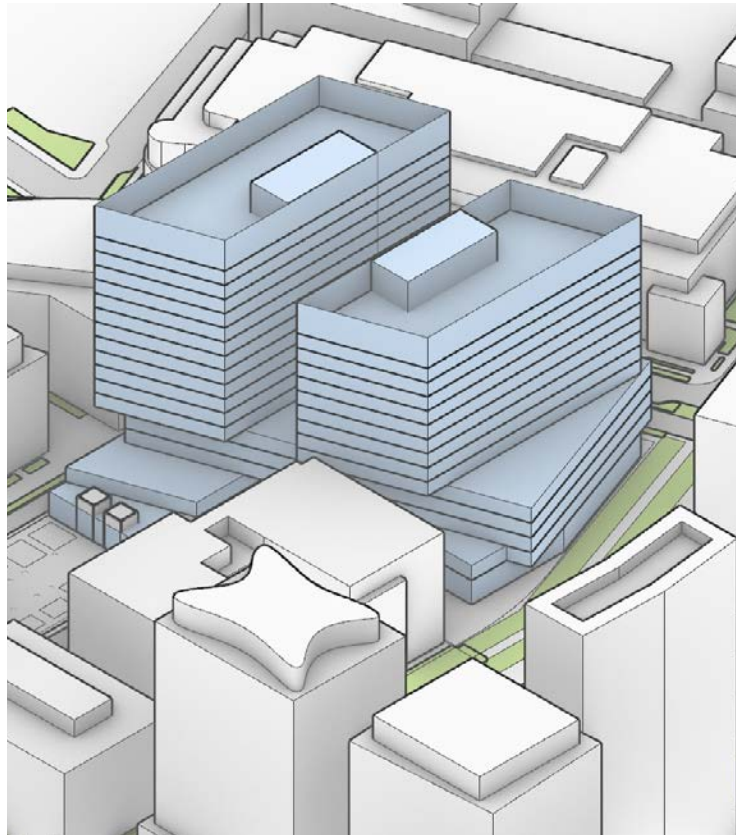

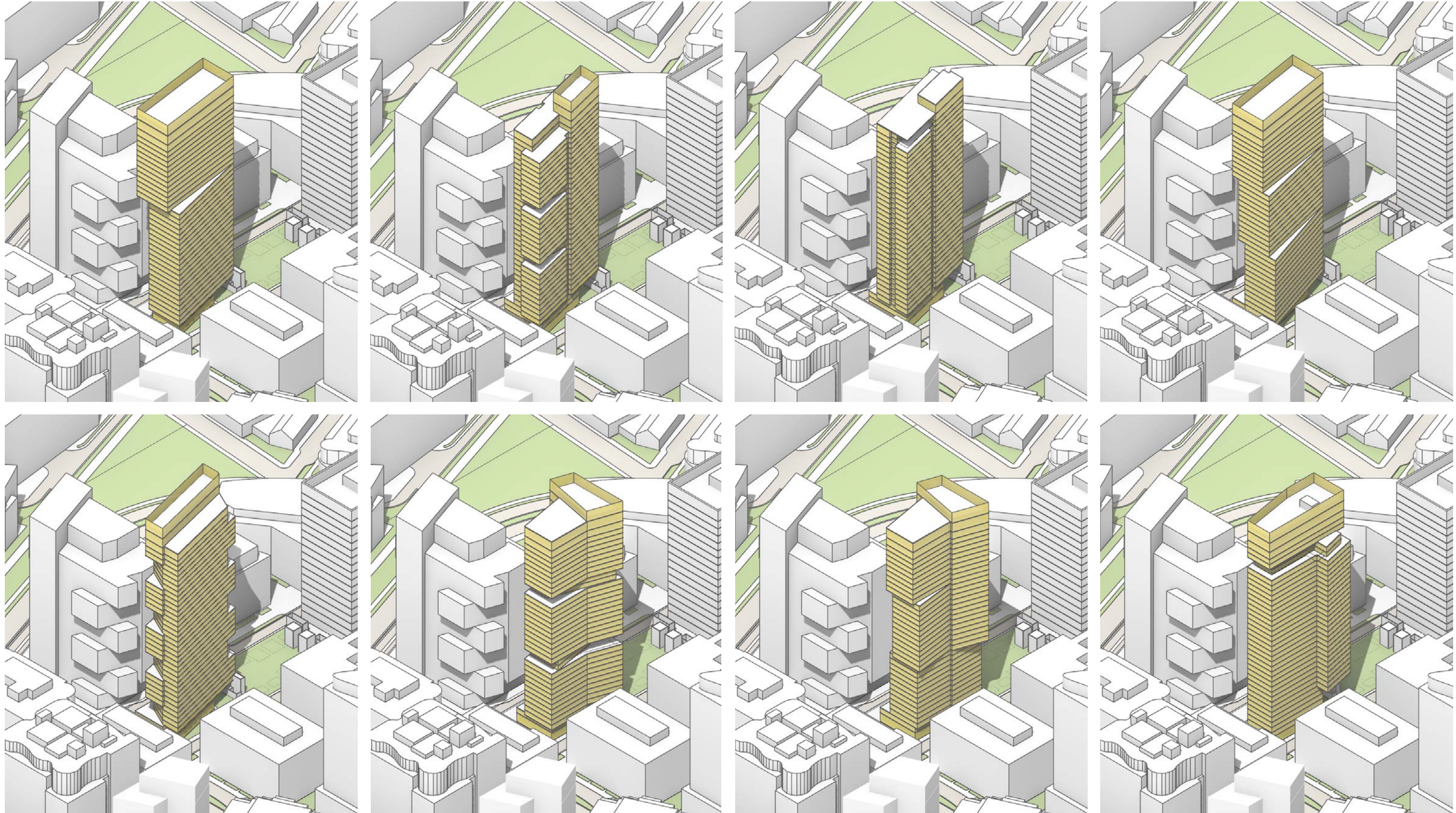



DISCUSSION