

325 MAIN STREET PUBLIC REALM

PUBLIC REALM PACKAGE UPDATE
March 4, 2020

bxp Boston
Properties

LEMON
BROOKE

SELBERT
PERKINS
DESIGN

 **Stantec**

PICKARD CHILTON

An architectural rendering of a modern building with a glass facade, overlaid with a semi-transparent red filter. The building features a prominent cantilevered upper section. The foreground shows a street scene with a bus, a car, a 'T' transit sign, and several pedestrians. The text 'FURNISHING LAYOUT' is centered in white, bold, uppercase letters.

FURNISHING LAYOUT

PROPOSED FURNISHING PLAN

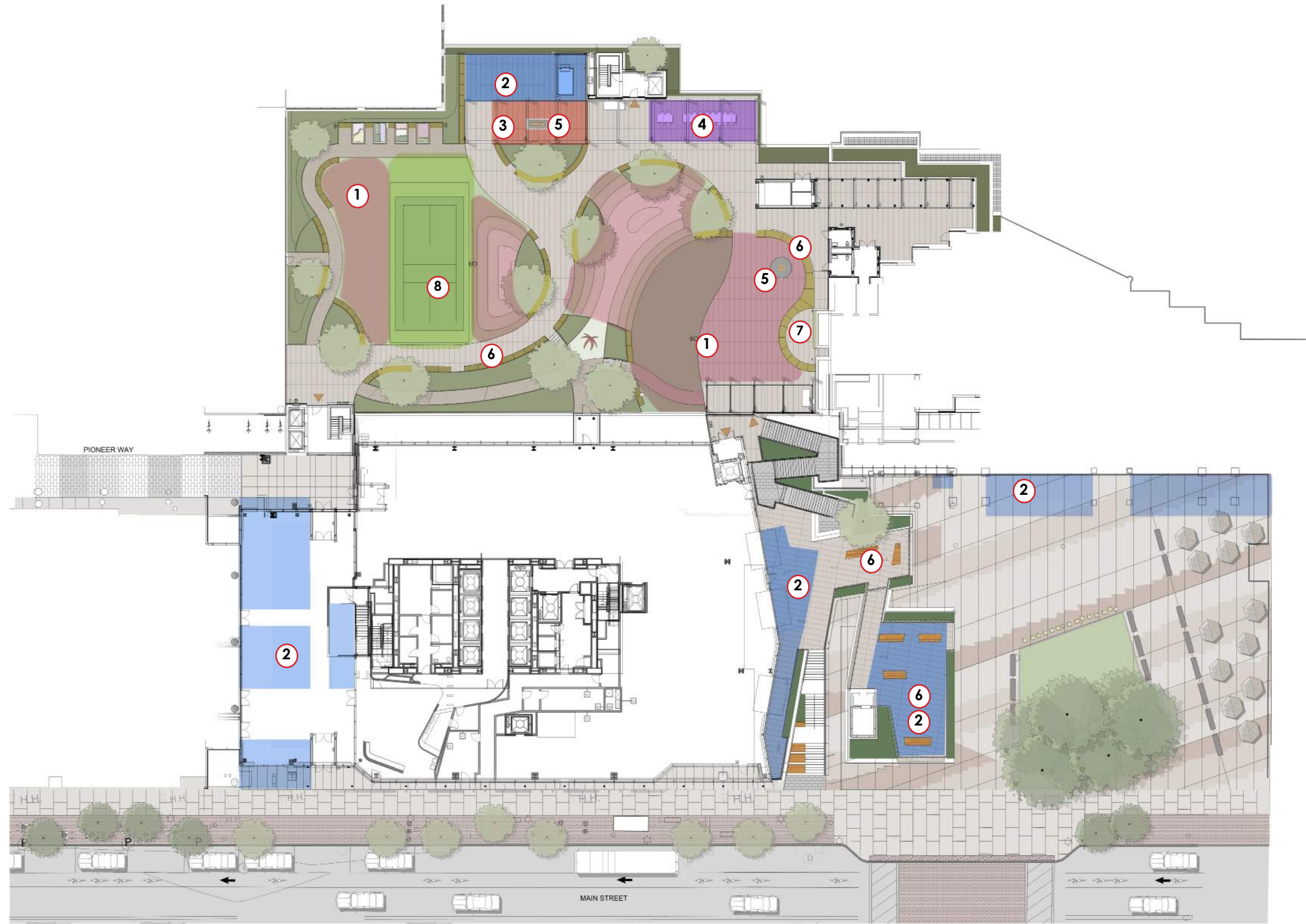

LEGEND

- ① FLEXIBLE FURNISHING
 - Moveable
 - Colorful
 - Wood and soft textures
 - Weatherproof and UV Stable
 - Useful for lounging, movie watching, playing, group gatherings, informal meetings
- ② CAFE DINING
 - 2 and 4 top tables
 - Informal cafe chairs with backs
 - Stackable
- ③ OUTDOOR LIVING ROOM
 - Cushioned couches or love seats
 - Colorful throw pillows
- ④ COMMUNITY DINING
 - Large table(s)
 - Moveable chairs with backs and wide stable bottoms
- ⑤ WARMING TABLES
 - Gas fire table with wide stone surrounds
 - Convertible to wood topped, low coffee tables
- ⑥ FIXED BENCHES
 - Stone benches with wood backs and underlighting
 - Include colorful throw pillows throughout
- ⑦ STAGE
 - 13" high stone and wood stage
 - Include lounge bags
- ⑧ SPORT COURT
 - Mini hoops
 - Pickle ball net
 - Badminton
 - Loose parts play such as big blocks



An architectural rendering of a modern building complex, featuring a prominent glass and steel structure with a trellis-like facade. The scene includes a street with a bus, cars, and pedestrians, and a tall building with a grid-like facade in the background. The entire image is overlaid with a semi-transparent red color.

KENDALL PLAZA TRELLIS

DESIGN RENDERING

TRELLIS REVISION

KENDALL PLAZA TRELLIS
EXISTING CONDITION



DESIGN RENDERING

TRELLIS REVISION

KENDALL PLAZA TRELLIS
PROPOSED REVISION



An architectural rendering of a modern building with a prominent social stair. The building features a glass facade and a large, cantilevered section. The scene includes a street with a bus, a car, and pedestrians. A red tint is applied to the entire image. The text "SOCIAL STAIR DIGITAL DESIGN" is centered in white.

SOCIAL STAIR DIGITAL DESIGN

CURRENT TERRA COTTA WALL



SOCIAL STAIR DIGITAL WALL OPTION 1

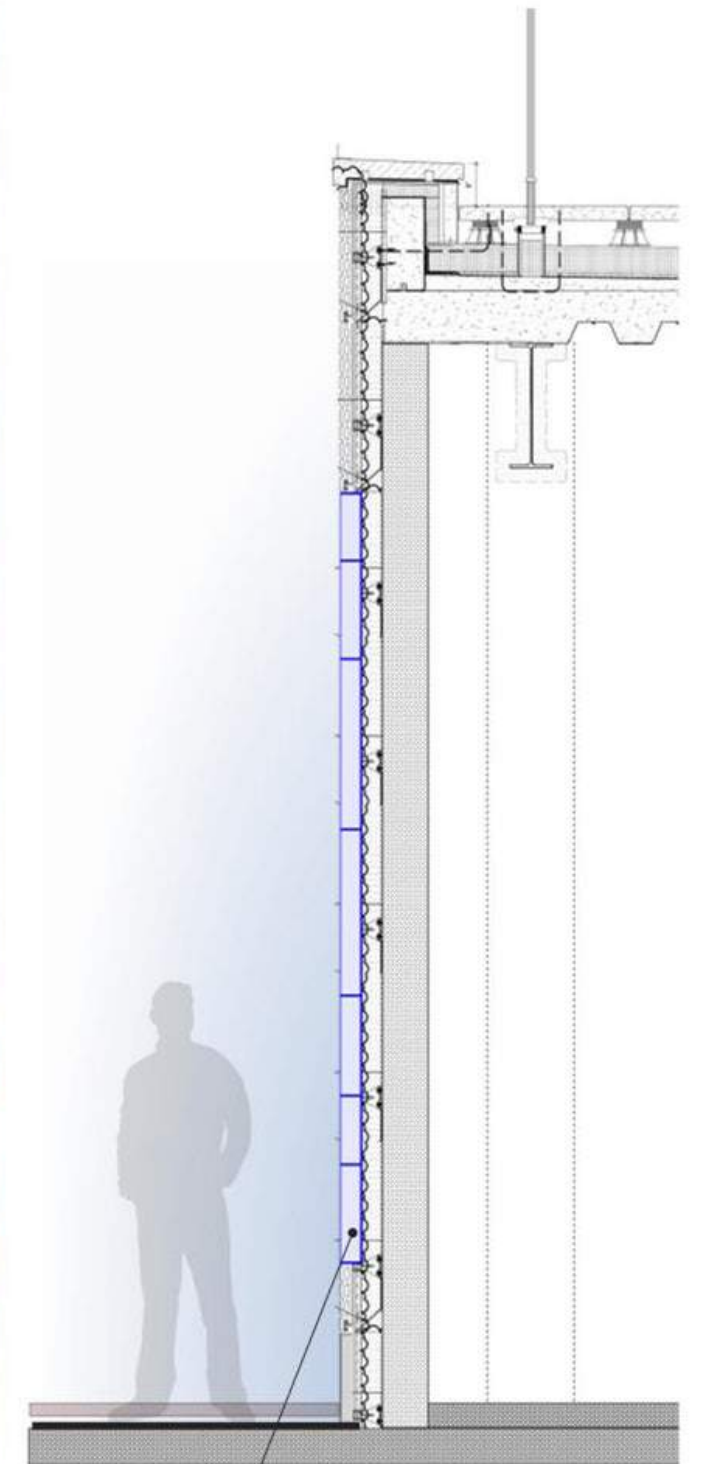

COMBINED EXTERIOR GRADE SCREENS,
INTEGRATED FLUSH WITH TERRA COTTA T
(28" x 15" LED SCREENS)

SOCIAL STAIR DIGITAL WALL OPTION 2

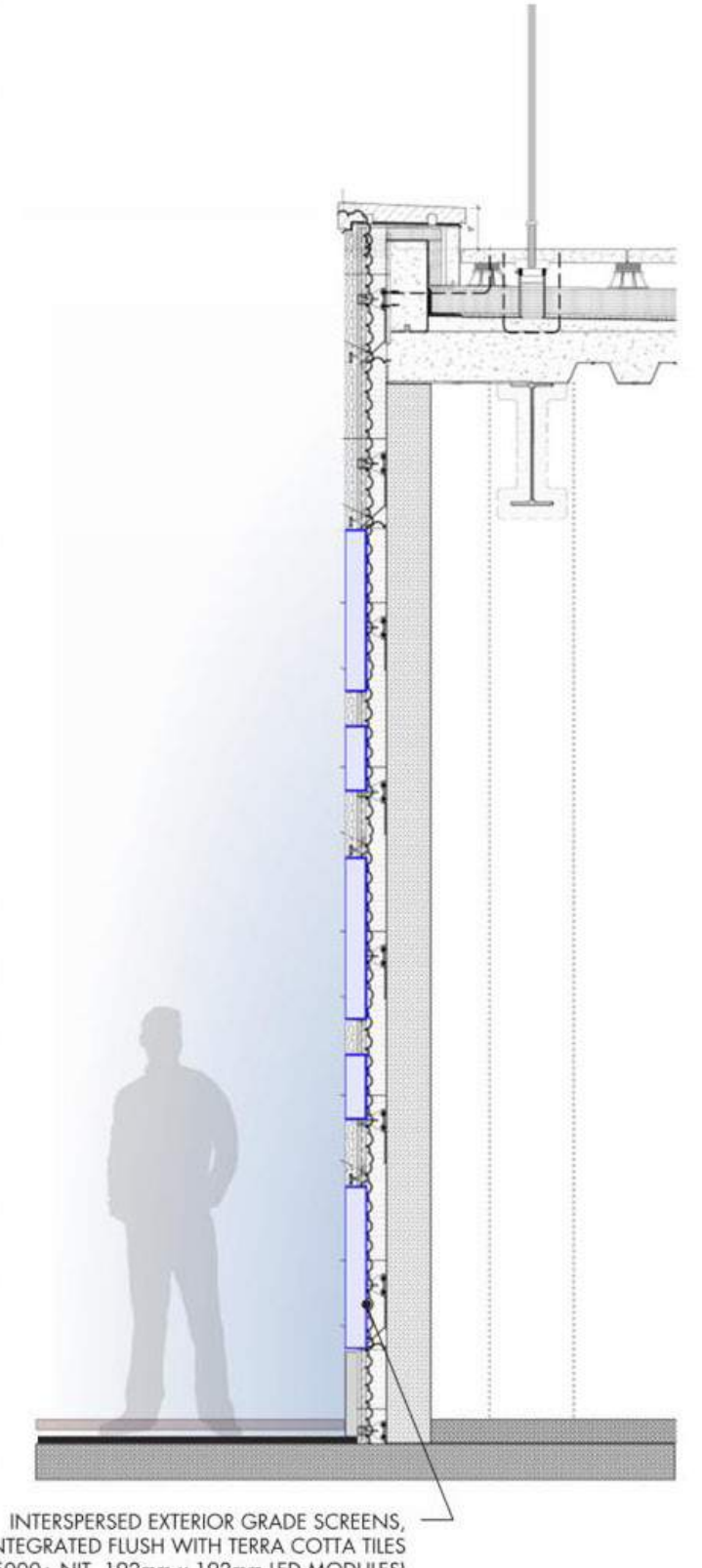

SOCIAL STAIR DIGITAL DESIGN PRECEDENTS

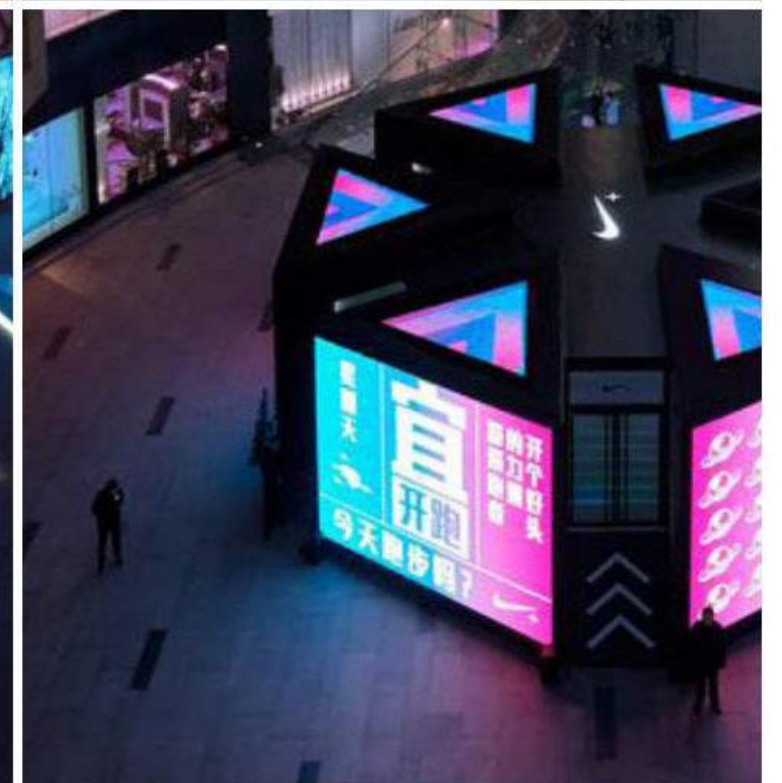
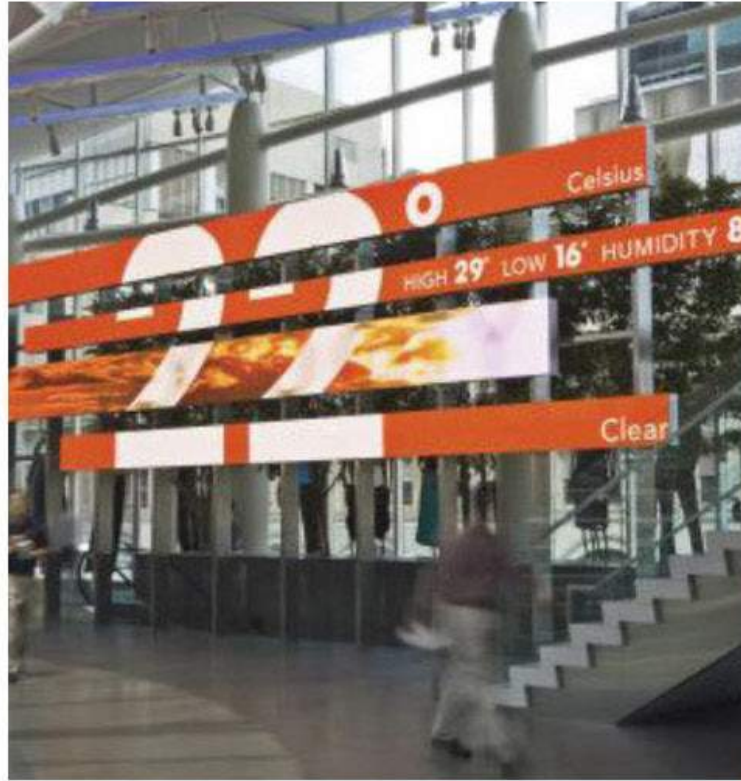



325 MAIN STREET BUILDING LIGHTING

BUILDING UPLIGHTING AT SLOPED PANELS

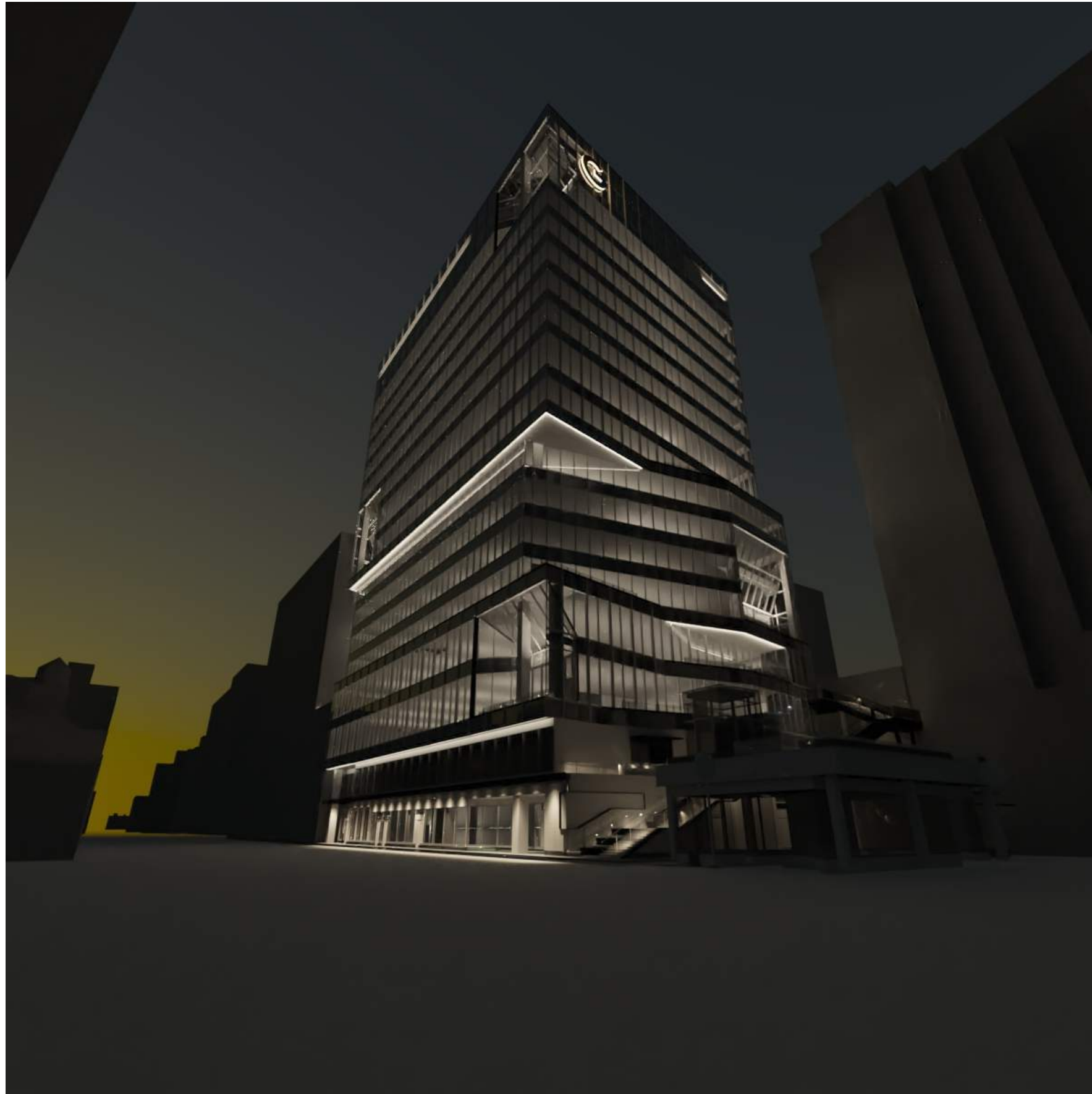

An architectural rendering of a modern, multi-story building with a glass facade and a prominent cantilevered upper section. The scene is overlaid with a semi-transparent red filter. In the foreground, a city street is depicted with a white bus, a car, and several pedestrians. A 'T' transit sign is visible on the sidewalk. To the right, another tall building with a grid-like window pattern is visible, along with some trees and a street lamp. The overall atmosphere is that of a vibrant urban environment.

ROOFTOP GARDEN

KENDALL SQUARE ROOFTOP GARDEN OVERVIEW

SECURITY GATE

MOTORIZED TRELLIS

KITCHEN

SPORTS COURT/TENTING AREA



KENDALL SQUARE ROOFTOP GARDEN ENLARGED PLAN

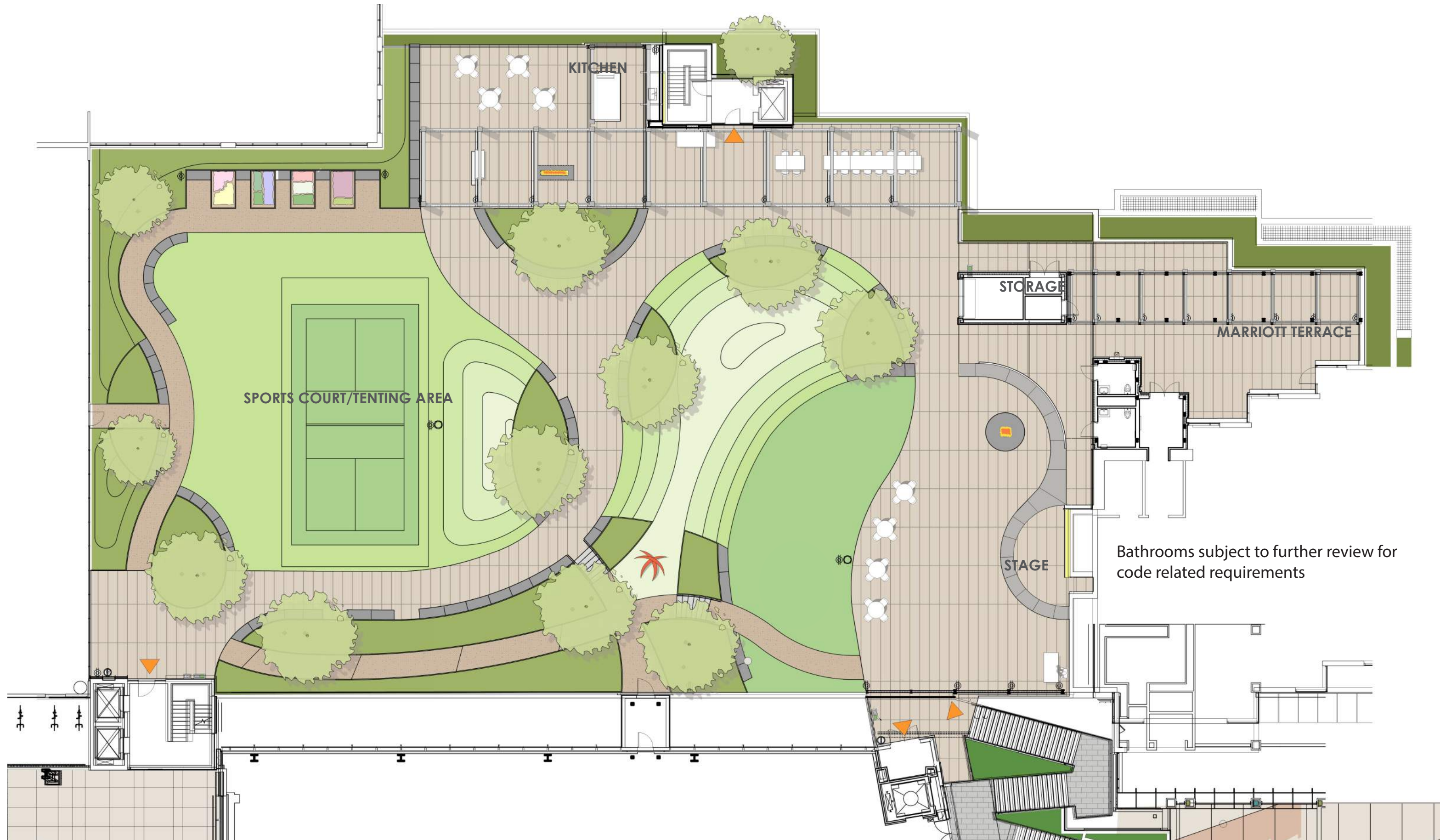

KENDALL SQUARE ROOFTOP GARDEN RESTROOM + STORAGE PAVILIONS



MATERIAL PALLETTE



FUTURE ART OPPORTUNITY



FIBER CEMENT



BLACKENED STEEL



WOOD DECKING

KENDALL SQUARE ROOFTOP GARDEN **MARRIOTT TERRACE**



MATERIAL PALLETTE



FUTURE ART OPPORTUNITY

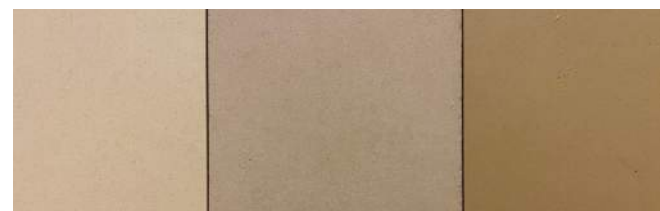

FIBER CEMENT

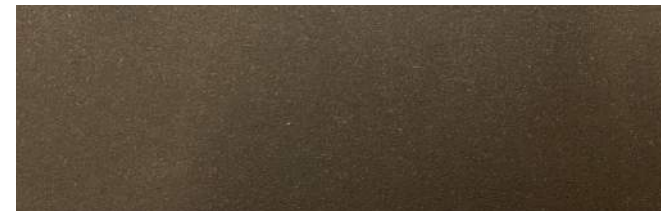

BLACKENED STEEL



WOOD DECKING

KENDALL SQUARE ROOFTOP GARDEN KITCHEN



MATERIAL PALLETTE



FUTURE ART OPPORTUNITY

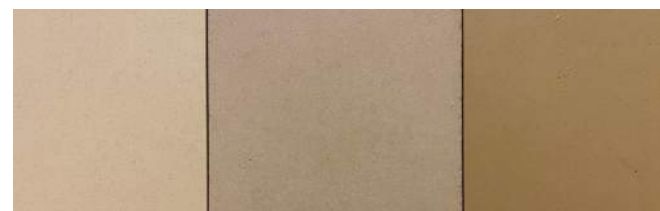

FIBER CEMENT

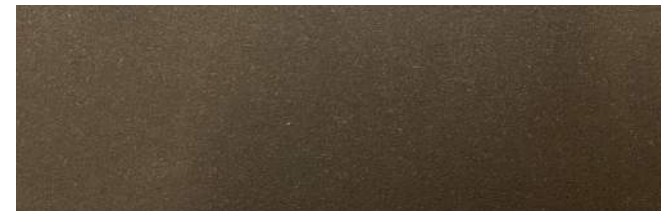

BLACKENED STEEL



WOOD DECKING

KENDALL SQUARE ROOFTOP GARDEN NORTH EAST STAIR/ELEVATOR TOWER



MATERIAL PALLETTE



FUTURE ART OPPORTUNITY

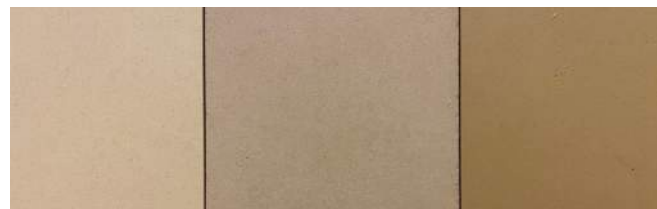

FIBER CEMENT



BLACKENED STEEL



WOOD DECKING

An architectural rendering of a modern skyscraper with a glass facade. A prominent feature is a cantilevered balcony on one of the upper floors, which is enclosed with a glazed handrail. The building is surrounded by other tall buildings, trees, and a street scene with a bus, cars, and pedestrians. The entire image has a semi-transparent pink overlay.

GLAZED HANDRAIL OPTIONS

EXISTING CONDITION VIEW FROM BROADWAY LOOKING EAST



CURRENT DESIGN VIEW FROM BROADWAY LOOKING EAST



PROPOSED GLAZED RAILING VIEW FROM BROADWAY LOOKING EAST



PROPOSED GLAZED RAILING VIEW FROM BROADWAY LOOKING WEST



PROPOSED GLAZED RAILING VIEW FROM BROADWAY LOOKING UP



PROPOSED GLAZED RAILING VIEW FROM BELOW

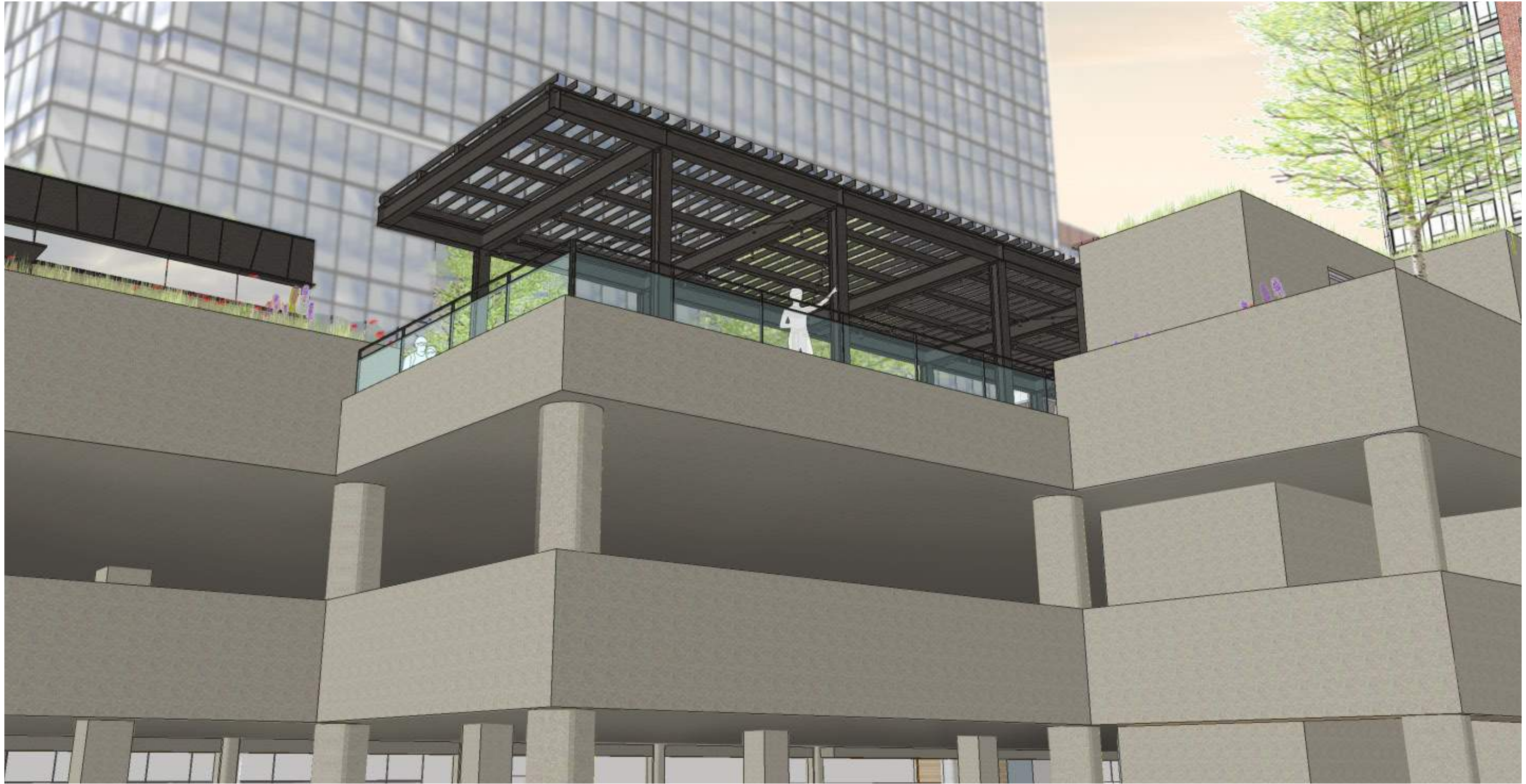

PROPOSED GLAZED RAILING VIEW FROM ROOF DECK



PROPOSED GLAZED RAILING VIEW FROM ROOF GARDEN



PROPOSED GLAZED RAILING VERTICAL DETAILS

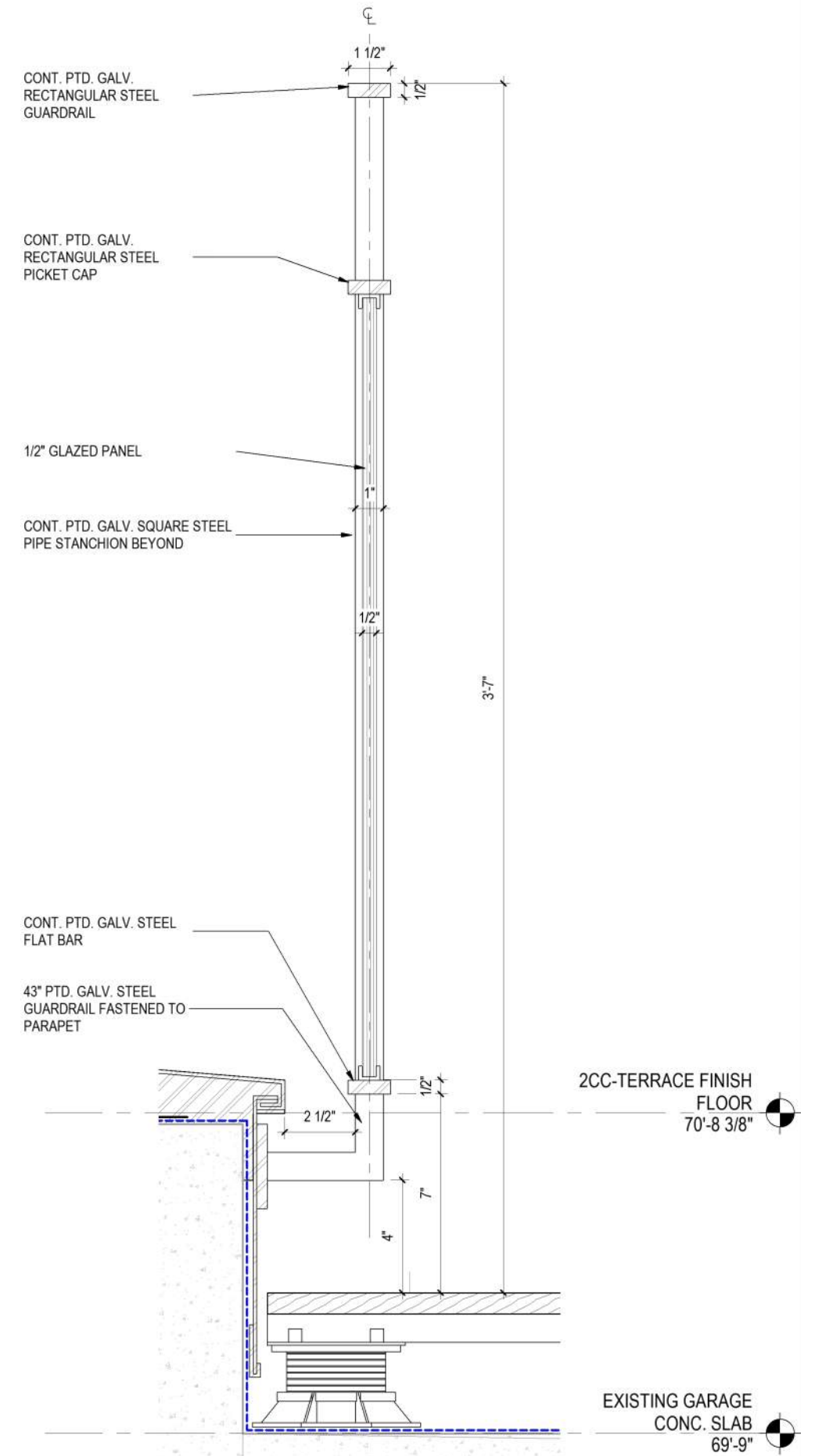
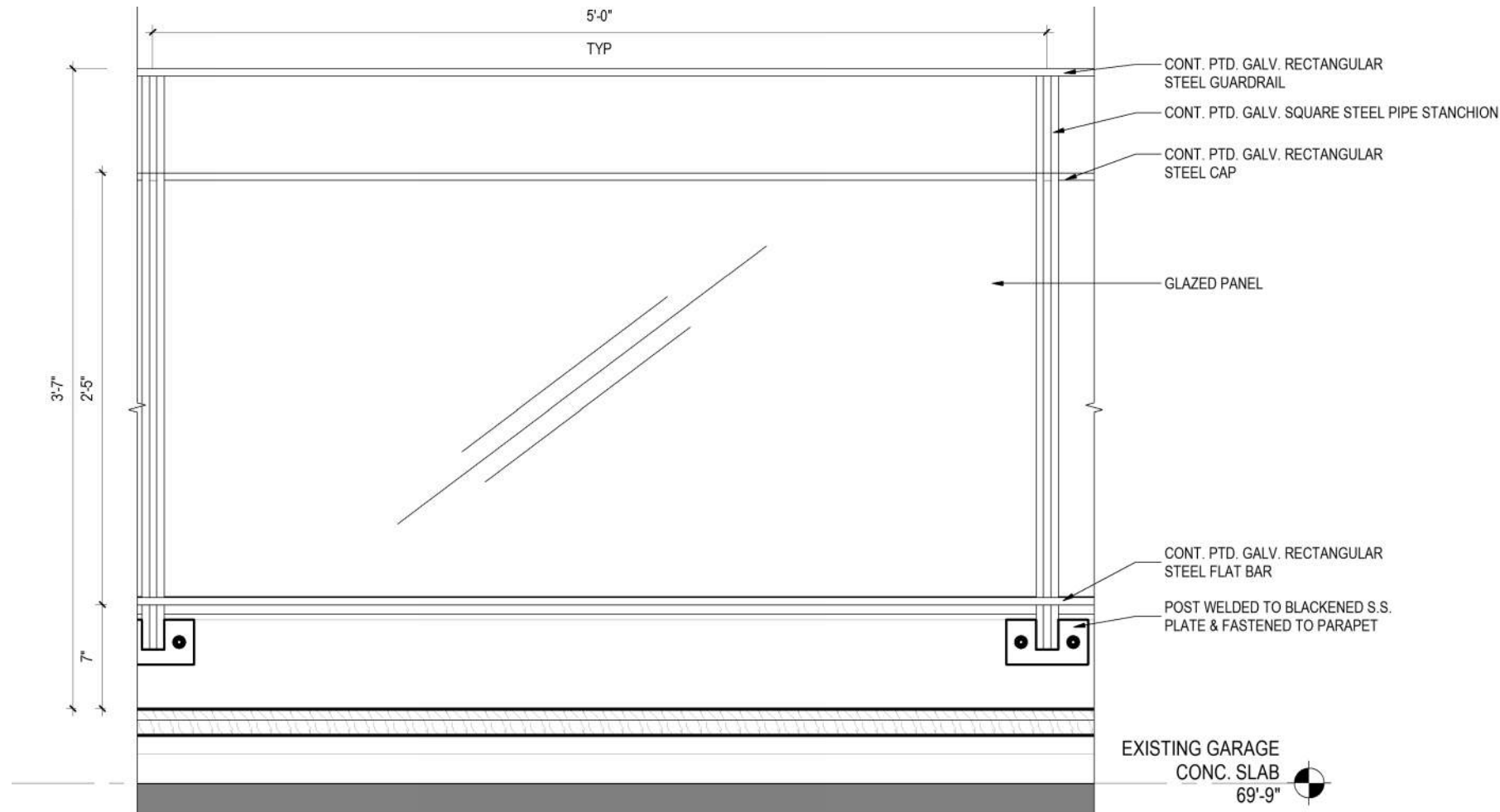



SECURITY GATE OPTIONS

OPTION 1 NEST PATTERN OPEN WITH LIVE EDGE WOOD BEAM & SIGNAGE

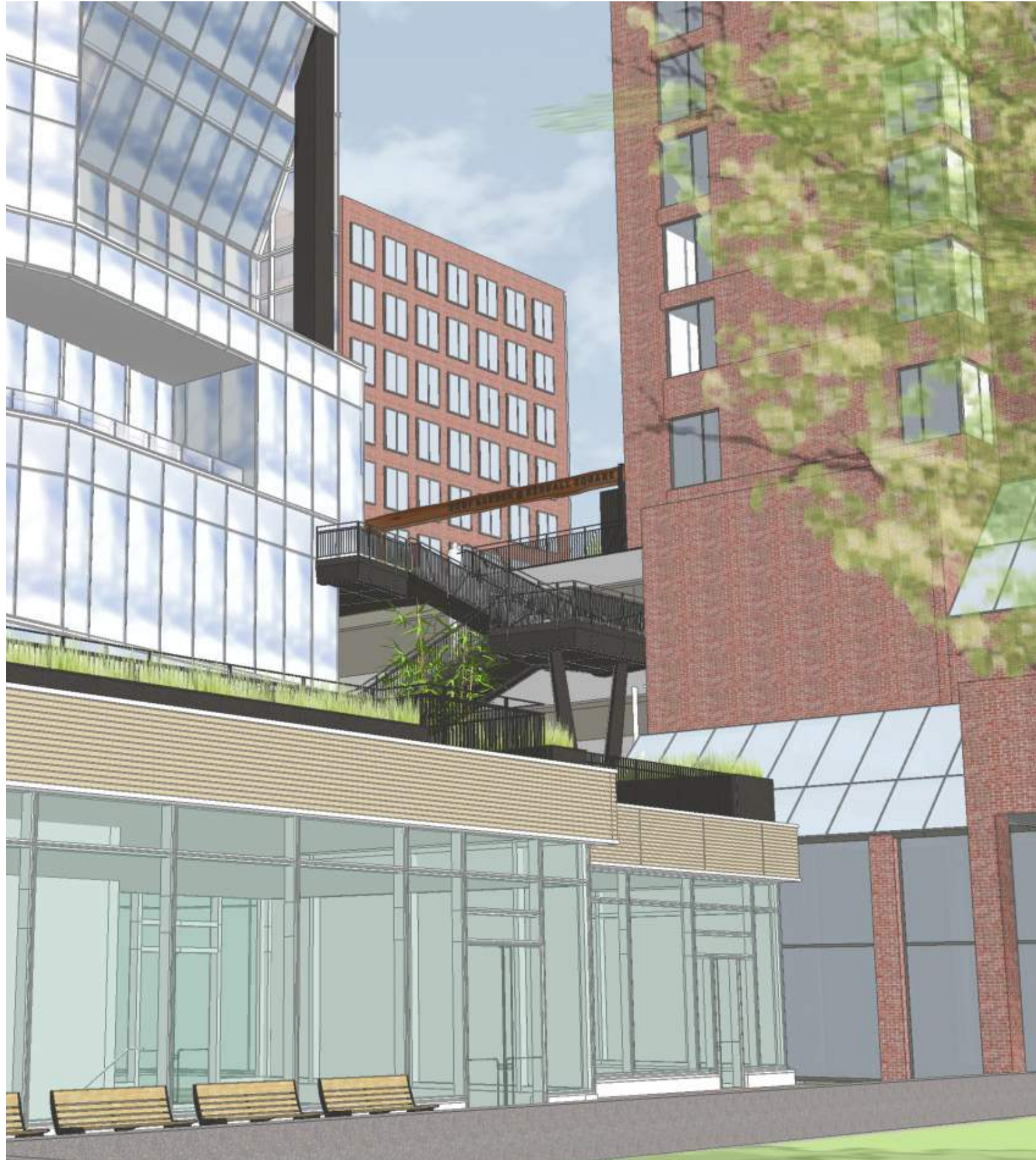

OPTION 1 NEST PATTERN OPEN WITH LIVE EDGE WOOD BEAM & SIGNAGE



OPTION 1 NEST PATTERN OPEN WITH LIVE EDGE WOOD BEAM & SIGNAGE



OPTION 1 NEST PATTERN CLOSED WITH LIVE EDGE WOOD BEAM & SIGNAGE



OPTION 1 NEST PATTERN CLOSED WITH LIVE EDGE WOOD BEAM & SIGNAGE



OPTION 1 NEST PATTERN CLOSED WITH LIVE EDGE WOOD BEAM & SIGNAGE

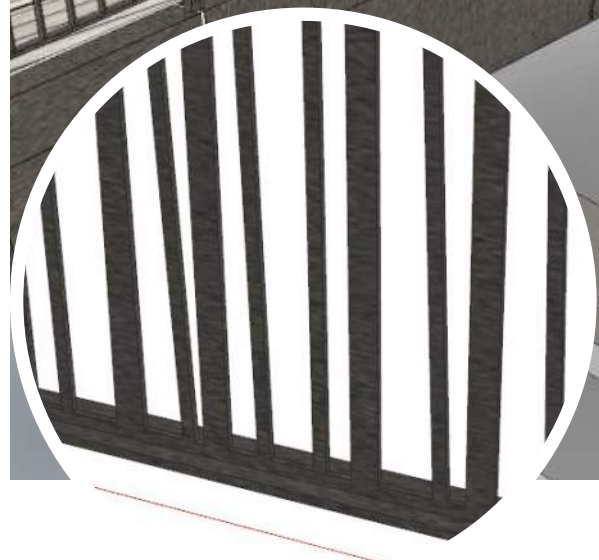

OPTION 2 NEST PATTERN OPEN WITH STEEL BEAM & SIGNAGE

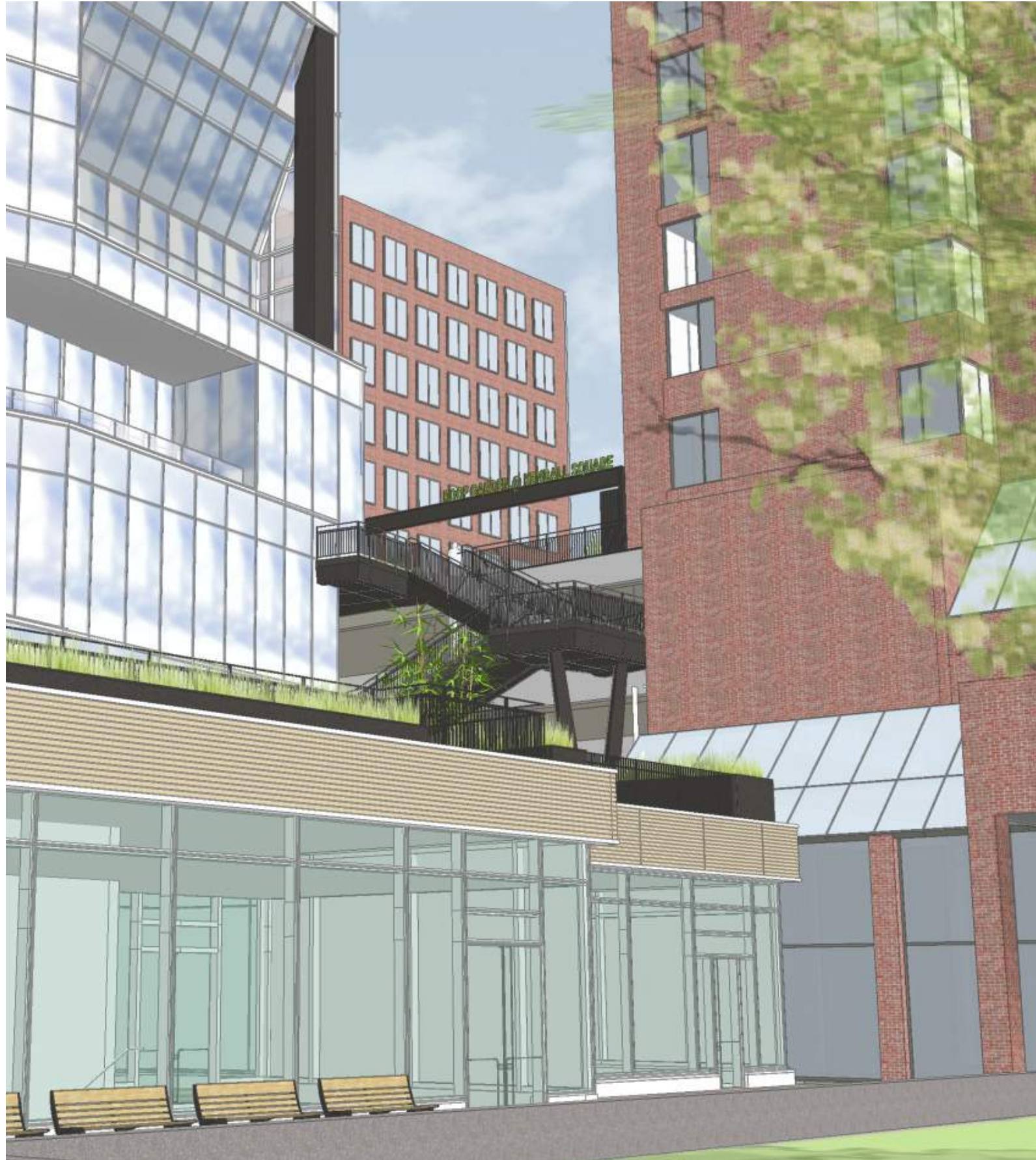

OPTION 2 NEST PATTERN OPEN WITH STEEL BEAM & SIGNAGE



OPTION 2 NEST PATTERN OPEN WITH STEEL BEAM & SIGNAGE



OPTION 2 NEST PATTERN CLOSED WITH STEEL BEAM & SIGNAGE



OPTION 2 NEST PATTERN CLOSED WITH STEEL BEAM & SIGNAGE



OPTION 2 NEST PATTERN CLOSED WITH STEEL BEAM & SIGNAGE

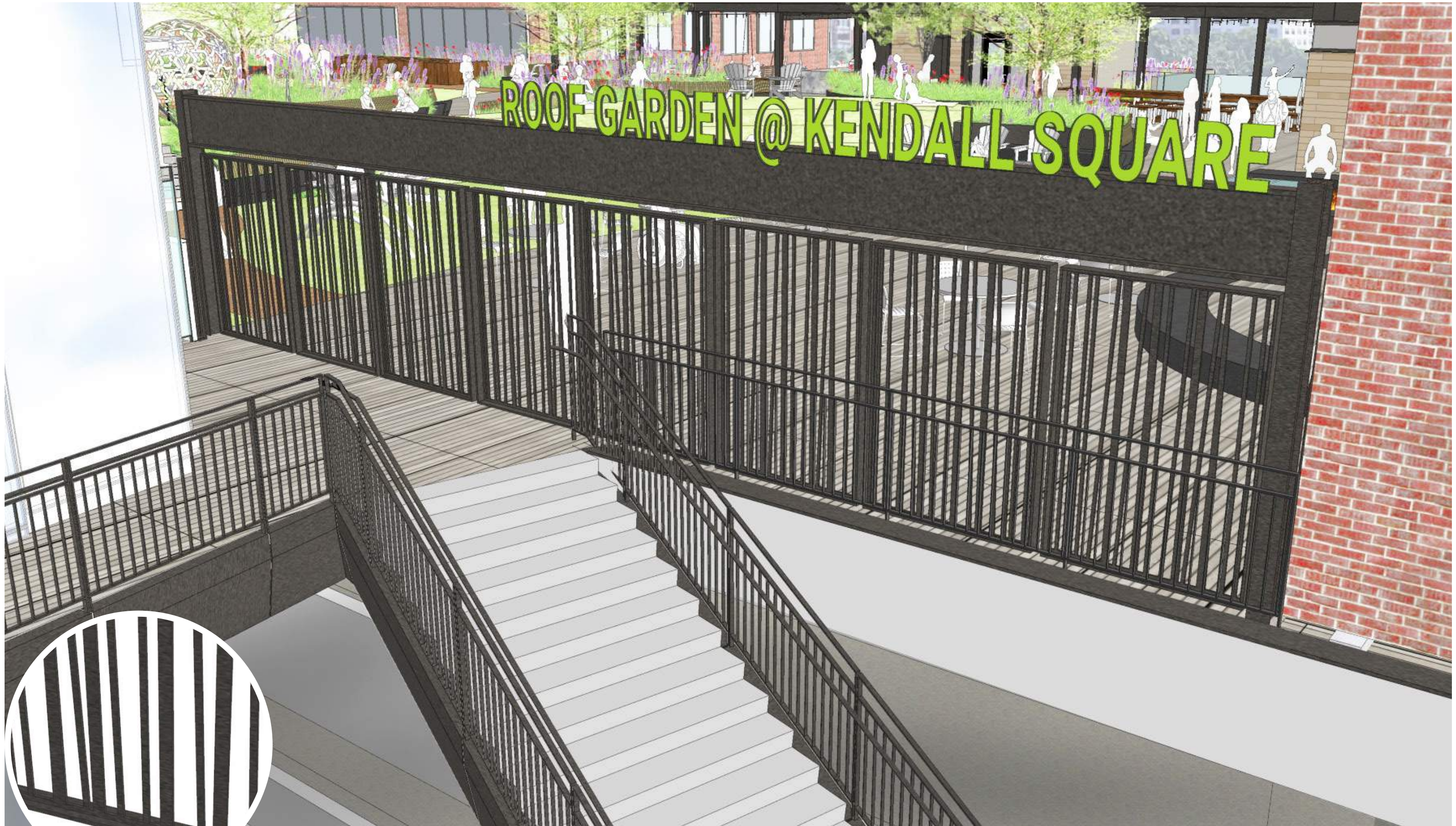

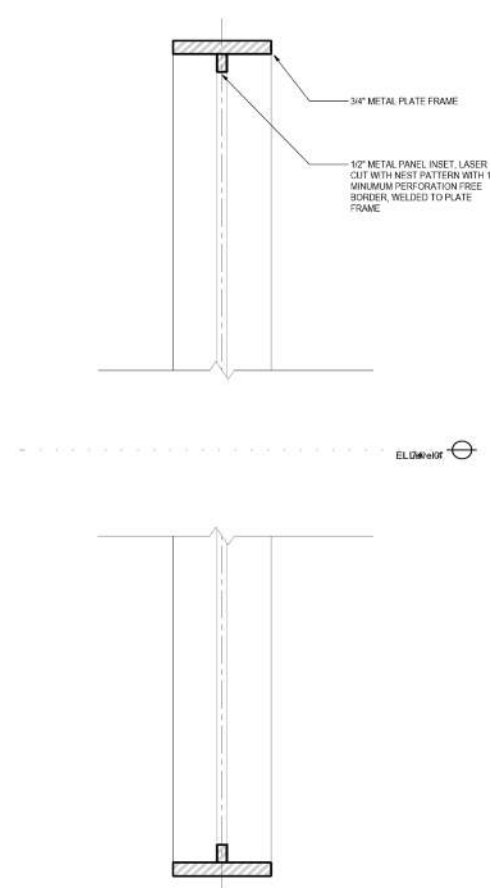

6 GATE PANEL SECTION - BI-FOLD OPTION 2
PR7.02 3\"/>

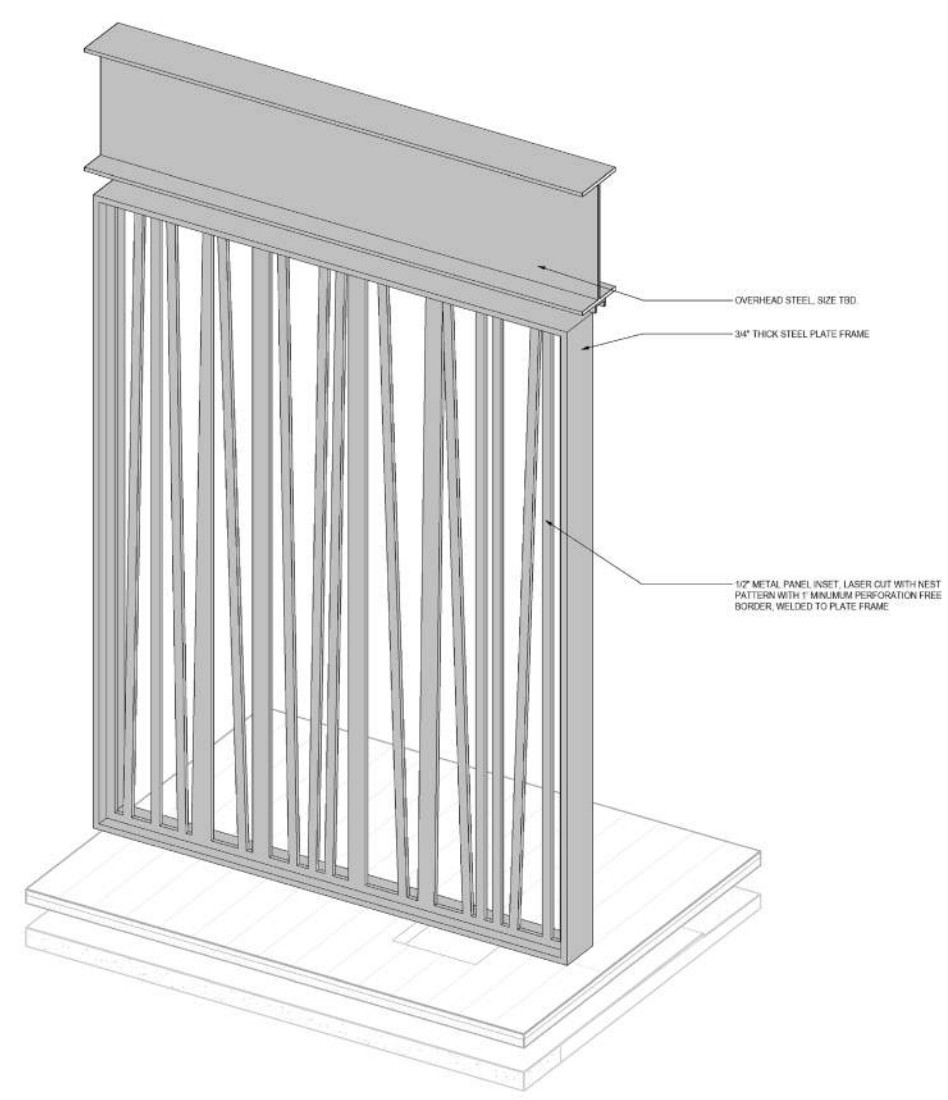

1 GREEN GARAGE GATE PANEL STUDY BI-FOLD OPTION 2 3D
PR7.02

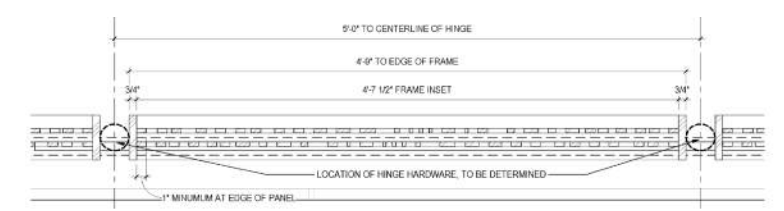

4 DETAIL PLAN - BI-FOLD OPTION 2
PR7.02 1 1/2\"/>

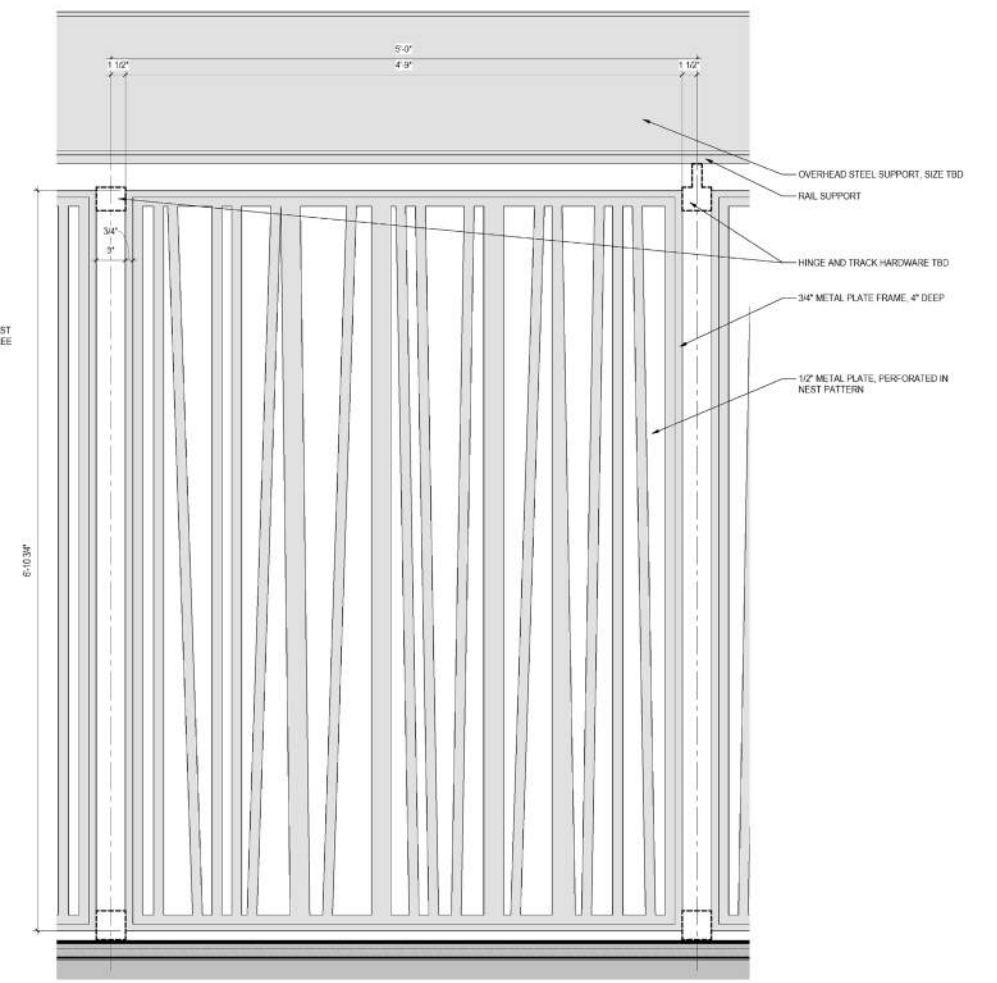

5 PANEL DETAIL ELEVATION BI-FOLD OPTION 2
PR7.02 1 1/2\"/>

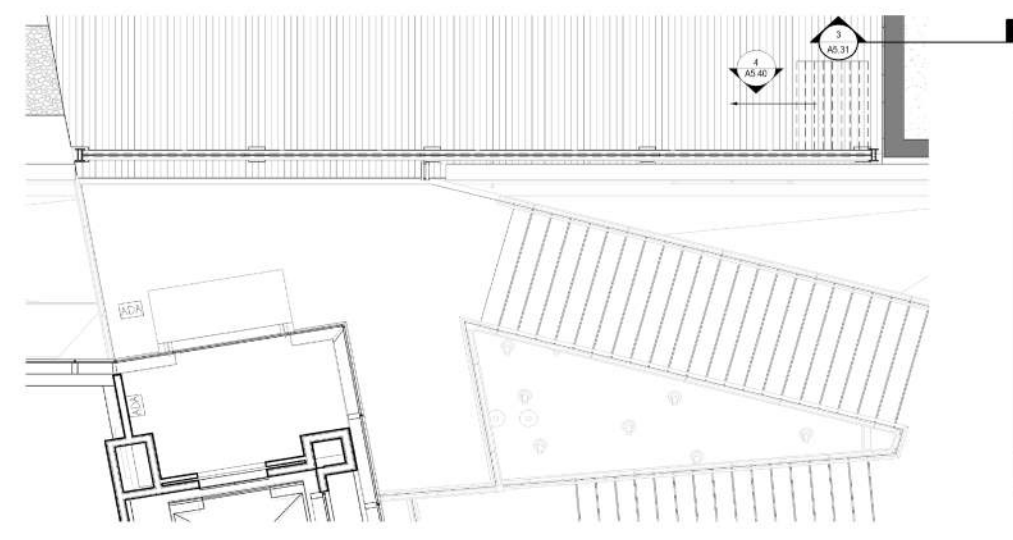

2 OVERALL PLAN - BI-FOLD OPTION 2
PR7.02 1/4\"/>

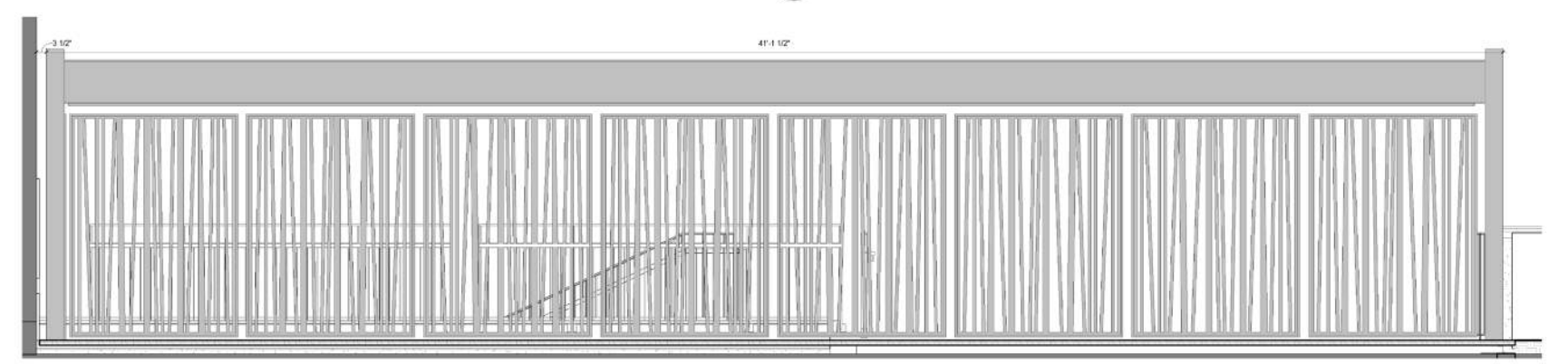

3 ENTRY GATE PANEL ELEVATION BI-FOLD OPTION 2 - CLOSED
PR7.02 1/2\"/>

An architectural rendering of a modern building with a glass facade and a rooftop garden. The scene is overlaid with a red tint. The building features a prominent cantilevered upper section. In the foreground, there is a street with a bus, a car, and several people walking. A transit stop sign with the letter 'T' is visible. The rooftop garden is partially visible on the right side of the building.

ROOFTOP GARDEN LIGHTING DESIGN

LIGHTING PLAN AMBIENT AND EGRESS LIGHTING

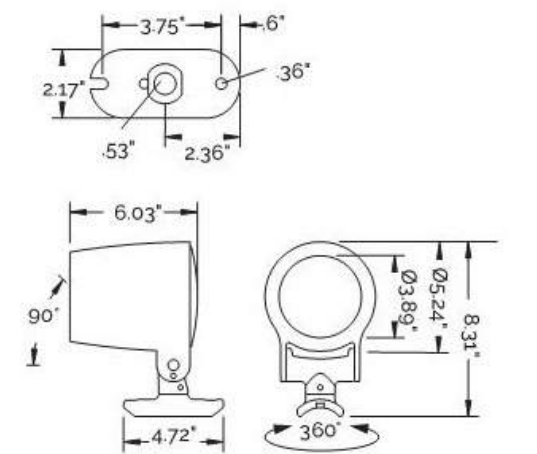

Meyer Monospot

LIGHTING PLAN TREE UPLIGHTING



BK Denali

LIGHTING PLAN UNDERBENCH LIGHTING

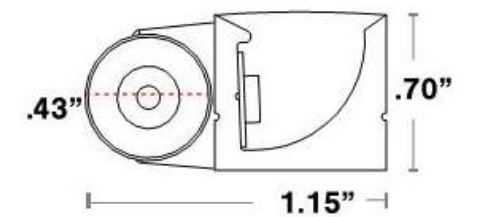

Q-Tran Kurv

LIGHTING PATHWAYS

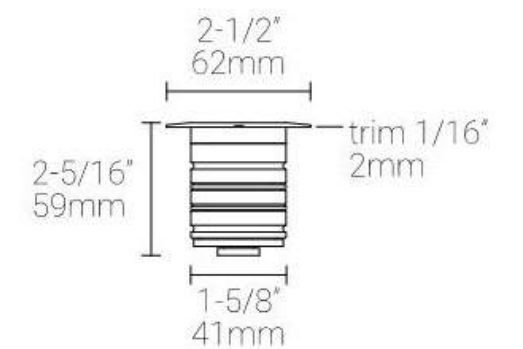
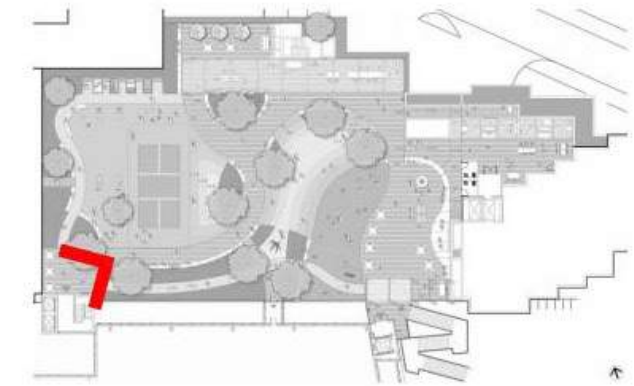

MP L01

LIGHTING COMMUNITY KITCHEN



BK El Capitan



Bega Wall



Luminii Kendo

LIGHTING **MOTORIZED TRELLIS**

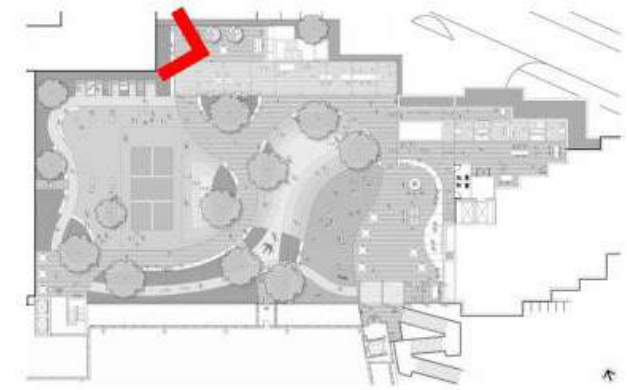

Bega Wall

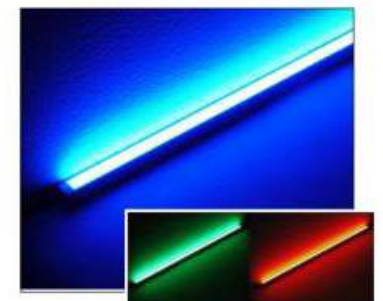

Luminii Kendo RGB



PlexiNeon Shapes

LIGHTING **MOTORIZED TRELLIS**



Bega Wall



Luminii Kendo RGB



PlexiNeon Shapes

LIGHTING RESTROOM / STORAGE PAVILIONS



BEGA Wall Downlight

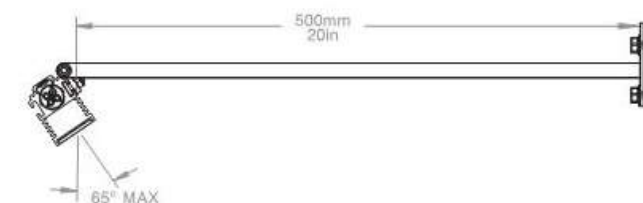

GVA STR9 Wall Bracket

An architectural rendering of a modern, multi-story building with a glass facade. The building features a prominent cantilevered section on the left side. In the foreground, there is a transit stop sign with a 'T' inside a circle. The scene includes a street with a bus, a car, and several people walking. The entire image is overlaid with a semi-transparent pink color.

THANK YOU.
QUESTIONS?

An architectural rendering of a modern skyscraper with a glass facade, featuring a prominent cantilevered section. The scene includes a street with a bus, cars, pedestrians, and trees. The entire image is overlaid with a semi-transparent red filter. The word "APPENDIX" is centered in white text.

APPENDIX

SIGNAGE + ENVIRONMENTAL GRAPHICS OVERALL SITE CONTEXT

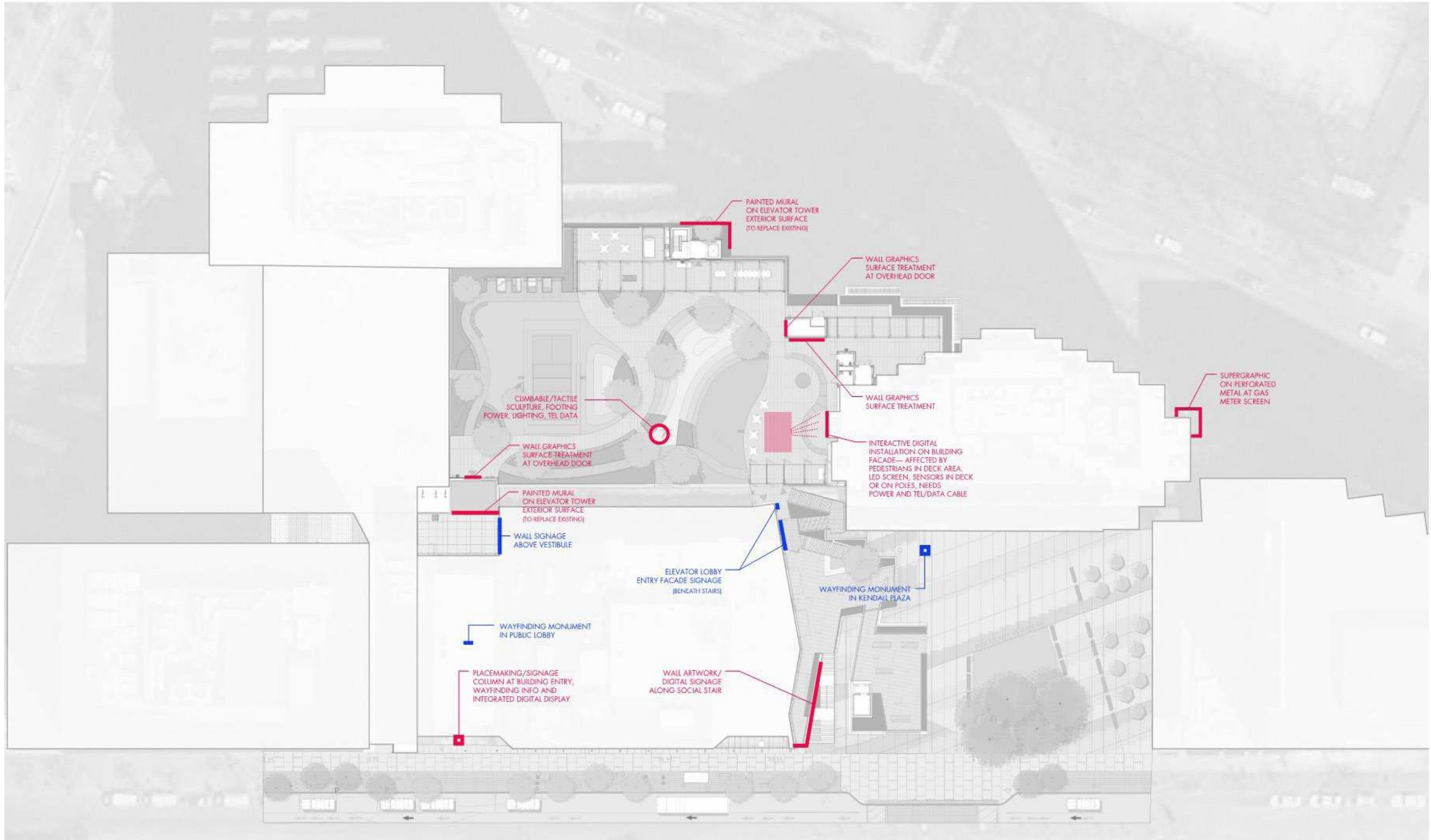

SIGNAGE + ENVIRONMENTAL GRAPHICS LEVEL 2 TERRACE

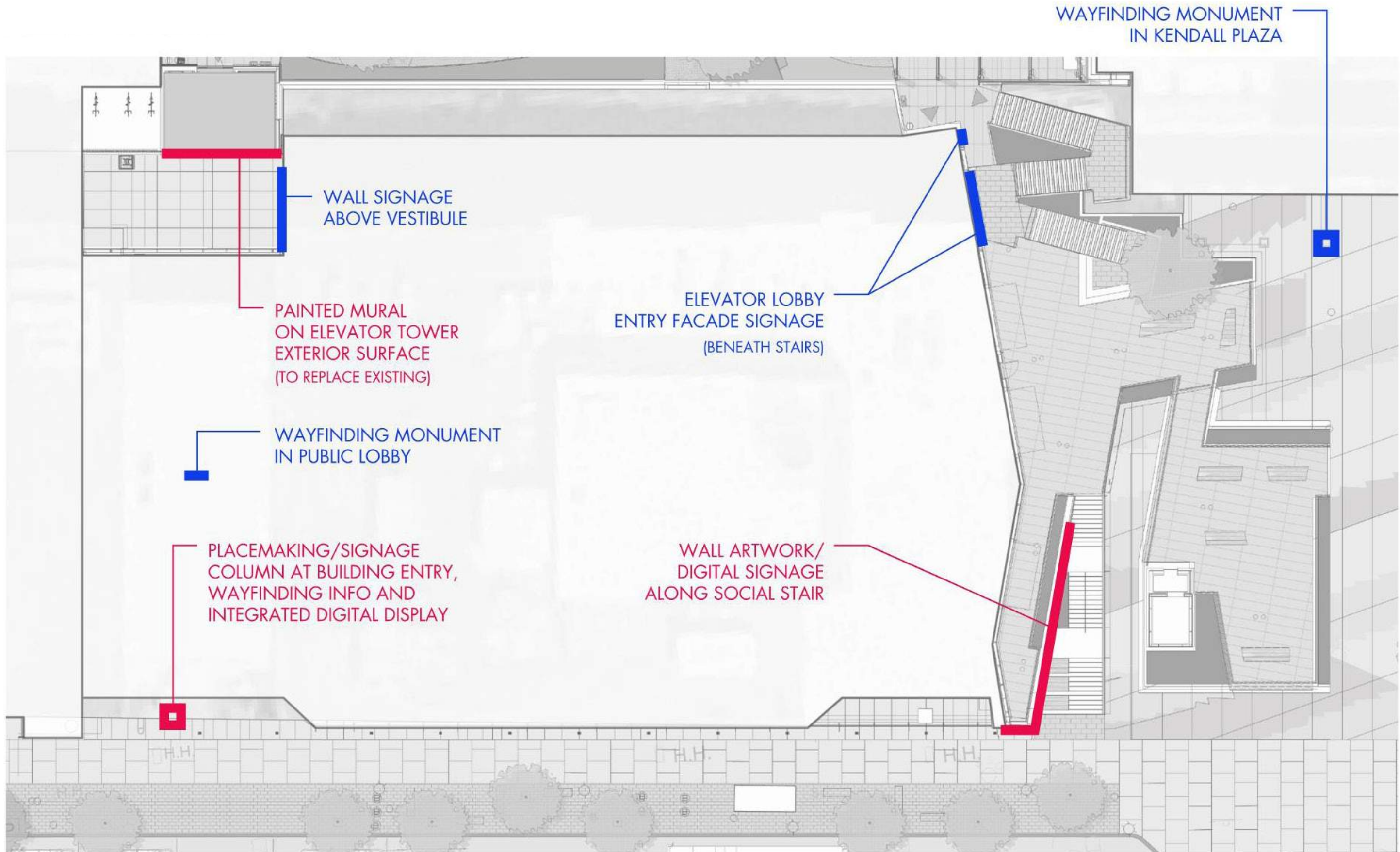

SIGNAGE + ENVIRONMENTAL GRAPHICS ROOF GARDEN

